

**hardware & accessories**

# General catalogue

Catálogo general



**more than you see**





**STaC**  
more than you see

▶	<b>ÍNDICE DE ICONOS</b> ICON INDEX	20 - 26
1	<b>BISAGRAS DE VENTANA Y PUERTA</b> WINDOW & DOOR HINGES	27 - 52
2	<b>MANILLAS Y CREMONAS DE VENTANA</b> WINDOW HANDLES & CREMONES	53 - 106
3	<b>MANILLAS Y TIRADORES DE PUERTA</b> DOOR & PULL HANDLES	107 - 128
4	<b>APERTURA PRACTICABLE</b> SIDE-HUNG OPENING	129 - 142
5	<b>APERTURA OSCIOBATIENTE</b> TILT & TURN OPENING	143 - 174
6	<b>HERRAJE EVO-SOFT</b> EVO-SOFT ENCASED HARDWARE	175 - 182
7	<b>HERRAJE EVO-SECURITY</b> EVO-SECURITY HARDWARE	183 - 190
8	<b>HERRAJE EVO-HYBRID</b> EVO-HYBRID HARDWARE	191 - 194
9	<b>COMPLEMENTOS</b> ACCESSORIES	195 - 212



10	<b>HOJA PASIVA</b> PASSIVE SASH	213 - 224
11	<b>APERTURAS PROYECTANTES Y ABATIBLES</b> TOP-HUNG & BOTTOM-HUNG OPENINGS	225 - 248
12	<b>CONTRAVENTANAS</b> WINDOW SHUTTERS	249 - 250
13	<b>SISTEMAS DE CORREDERA ELEVABLE</b> LIFT & SLIDE SYSTEMS	251 - 274
14	<b>VENTANAS CORREDERAS</b> SLIDING WINDOWS	275 - 306
15	<b>ESCUADRAS DE VENTANA</b> WINDOW CORNER JOINTS	307 - 312
16	<b>MÁS PRODUCTOS</b> MORE PRODUCTS	313 - 318
17	<b>MAQUINARIA</b> MACHINERY	319 - 328
18	<b>HERRAJE PARA CANAL 16</b> 16 GROOVE HARDWARE	329 - 366
19	<b>HERRAJE ANODIZADO</b> ANODISED HARDWARE	367 - 374

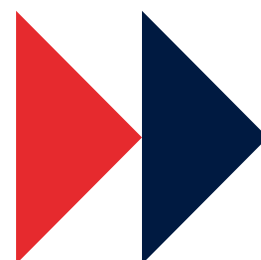

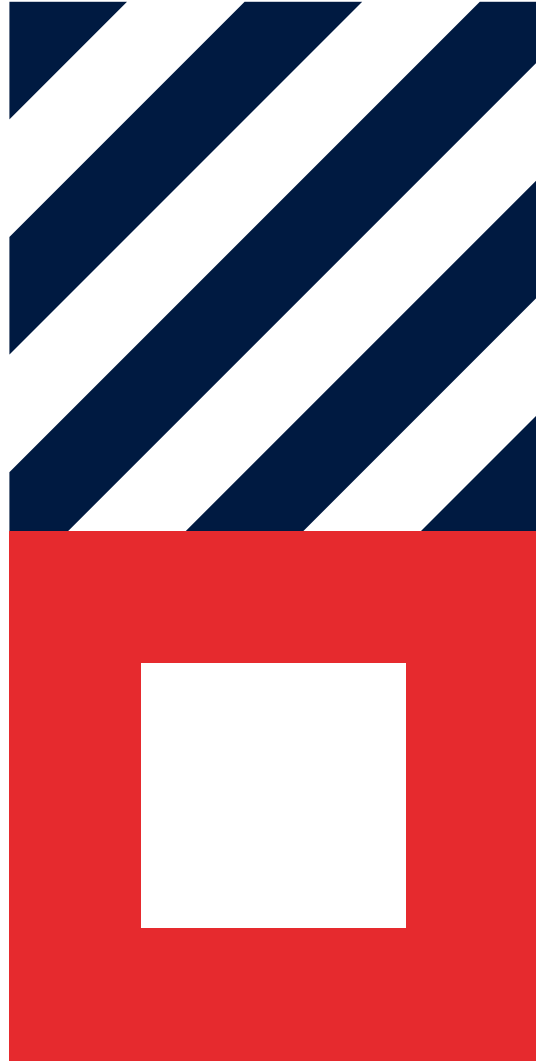

**Somos más**  
*que una*  
*empresa.*

We are more than a company





**Somos  
vanguardia,  
creatividad,  
responsabilidad**

We are avant-garde, creativity, responsibility



**Diseñamos  
y fabricamos**  
todo tipo de  
herraje  
y accesorios

**We design and manufacture**  
all types of hardware and accessories

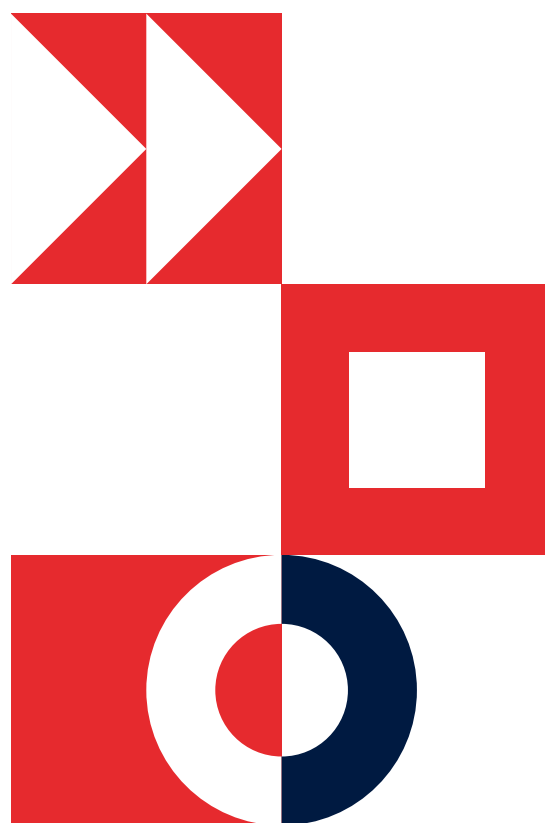





**herraje y accesorios**  
hardware and accessories



**juntas de estanqueidad**  
sealing gaskets

# STAC

**perfiles de poliamida**  
polyamide profiles



**oficinas técnicas**  
technical offices

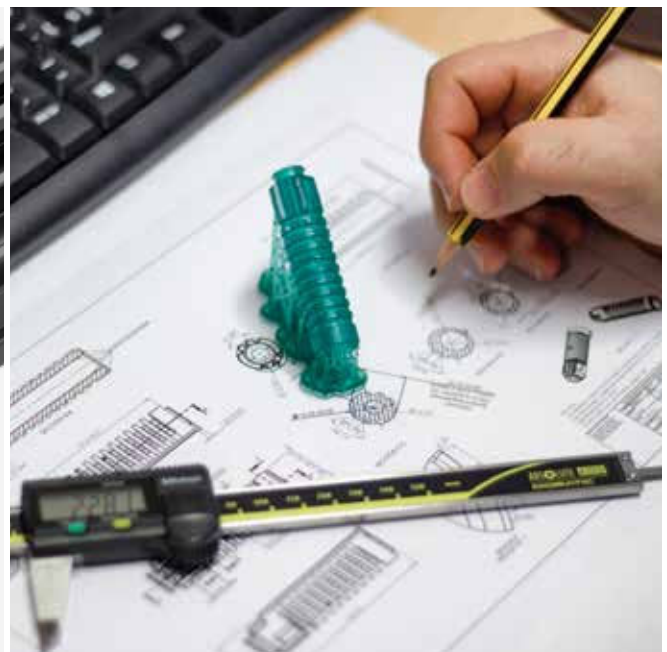



# **Soluciones para sistemas de aluminio**

Solutions for aluminium systems



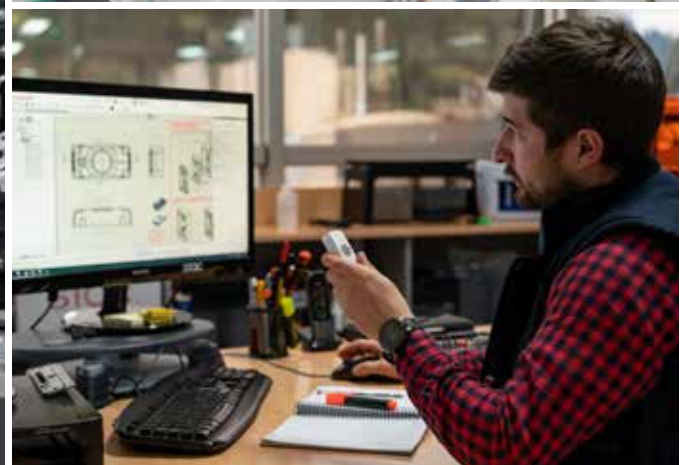
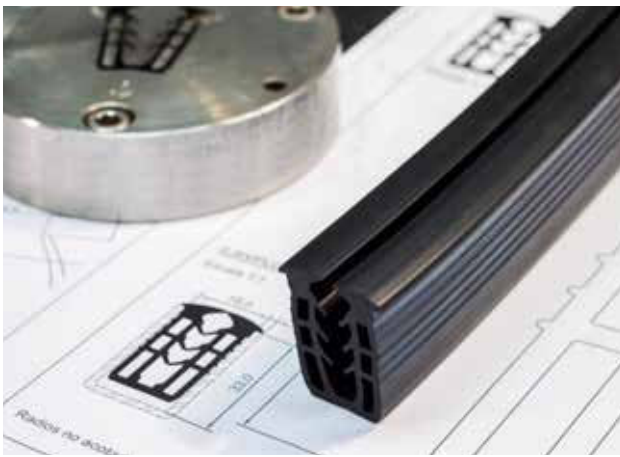



# Tenemos un gran equipo de ingenieros y diseñadores de producto

**We have a great team**  
of engineers and product designers

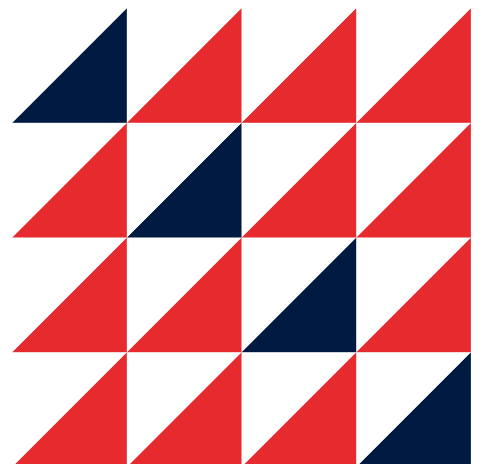

# Complejo productivo

## 50.000 m<sup>2</sup>

Production complex



**Alcance**  
**70 países**

outreach 70 countries



**I + D + I**  
**6 oficinas técnicas**

6 technical offices



**Especialización**  
**80 ingenieros**

80 specialised engineers



**Sedes**  
**5 delegaciones**

5 delegations



**Infraestructura**  
**120,000 m<sup>2</sup>**

facilities of 120.000 m<sup>2</sup>



**Personal**  
**500 empleados**

500 employees





# Más que personas, **es el talento de un equipo**

More than people,  
it is the talent of a team



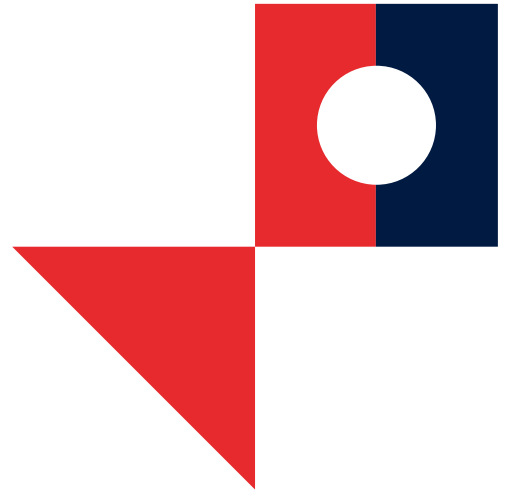

# Catálogo general de herraje y accesorios

General catalogue of hardware and accessories



**DESCRIPCIÓN** DESCRIPTION

<b>A</b>	<b>NOMBRE + DESCRIPCIÓN DEL PRODUCTO</b> NAME + PRODUCT DESCRIPTION	<b>E</b>	<b>CARACTERÍSTICAS TÉCNICAS PRINCIPALES DEL PRODUCTO</b> MAIN TECHNICAL CHARACTERISTICS OF THE PRODUCT
<b>B</b>	<b>REFERENCIA (S) DEL PRODUCTO</b> PRODUCT REFERENCE (S)	<b>F</b>	<b>TIPOS DE APERTURA COMPATIBLES CON EL PRODUCTO</b> TYPES OF OPENING COMPATIBLE WITH THE PRODUCT
<b>C</b>	<b>UNIDADES DEL PRODUCTO POR CAJA</b> PRODUCT UNITS PER BOX	<b>G</b>	<b>ESQUEMAS TÉCNICOS DEL PRODUCTO</b> TECHNICAL DIAGRAMS OF THE PRODUCT
<b>D</b>	<b>ACABADOS, MATERIALES Y OTRAS ESPECIFICACIONES</b> FINISHES, MATERIALS AND OTHER SPECIFICATIONS	<b>H</b>	<b>PRODUCTO (S) DE CARACTERÍSTICAS SIMILARES AL PRINCIPAL</b> PRODUCT (S) WITH SIMILAR CHARACTERISTICS TO THE MAIN ONE

**CREMONAS SIRIUS PARA APERTURA PRACTICABLE**  
SIDE-HUNG WINDOW SIRIUS CREMONES

**CREMONAS PRACTICABLES SIRIUS**  
SIRIUS SIDE-HUNG CREMONES

**A0790** \*\* Derecha Right  
**A0791** \*\* Izquierda Left

20

**CREMONA PRACTICABLE SIRIUS SLIM**  
SIRIUS SLIM SIDE-HUNG CREMONE

**A0790S** \*\*

20

**CREMONAS A LA FRANCESA SIRIUS**  
SIRIUS FRENCH STYLE CREMONES

**A0794** \*\* Pala corta Short lever  
**P0794** \*\* Pala larga Long lever

20

**Cremonas de ventana practicable.**  
Cremones for side-hung windows.

- Cremonas con diseño de líneas puras y estilizadas compatibles con el sistema de fijación rápida FAST.
- Las palas y los piñones de las cremonas se han fabricado en acero.
- Por cada caja de cremonas de apertura a derechas se suministran cinco kits de palas para aperturas a izquierdas.

**Cremona SIRIUS SLIM**

- La cremona SIRIUS SLIM es la solución ideal para instalaciones en ventanas o puertas balconeras en donde la persiana no habilita el espacio necesario para el montaje de una cremona tradicional.

**Cremones for side-hung windows.**

- Cremones with a pure and stylized lines design compatible with the FAST quick fastening system.
- The levers and pinions of the cremona are made of steel.
- Five lever kits for left-hand opening are supplied for each box of right-hand opening cremones.

**SIRIUS SLIM cremone**

- The SIRIUS SLIM cremone is envisaged as the ideal solution for installations on windows or balcony doors where the shutters do not leave the space necessary for the mounting of a traditional cremone.

**G**

**H**

58 MANILLAS Y CREMONAS - HANDLES AND CREMONES 02 STAC



» **DESGLOSE DE LA REFERENCIA** REFERENCE BREAKDOWN

023	D	**	R
	I		
A	B	C	D

**DESCRIPCIÓN** DESCRIPTION



A	023	<b>RAÍZ DE LA REFERENCIA DEL PRODUCTO</b> PRODUCT REFERENCE ROOT	C	**	<b>DISPONIBLE EN DIFERENTES ACABADOS</b> AVAILABLE IN DIFFERENT FINISHES
		<b>D</b>			<b>PRODUCTO VÁLIDO PARA APERTURA A DERECHAS</b> PRODUCT VALID FOR RIGHT-HAND OPENING
B	I	<b>PRODUCTO VÁLIDO PARA APERTURA A IZQUIERDAS</b> PRODUCT VALID FOR LEFT-HAND OPENING	D	S	<b>EL PRODUCTO INCLUYE CREMONA SIRIUS</b> THE PRODUCT INCLUDES SIRIUS CREMONE

Pueden aparecer otros dígitos a mayores para completar la referencia del producto.



Other digits may appear larger to complete the product reference.

» **ACABADOS DISPONIBLES** AVAILABLE FINISHES

**EN STOCK** IN STOCK

	00	<b>ACABADO CRUDO O SIN ACABADO</b> PLAIN FINISH OR UNFINISHED
	01	<b>ACABADO EN LACADO BLANCO</b> WHITE LACQUER FINISH
	02	<b>ACABADO EN LACADO NEGRO</b> BLACK LACQUER FINISH

\* **NO DISPONIBLES EN STOCK** NOT AVAILABLE IN STOCK

	81	<b>ACABADO EN ANODIZADO NATURAL MATE</b> NATURAL MATT ANODIZED FINISH		91	<b>ACABADO ESPECIAL 01</b> SPECIAL FINISH 01
		<b>ACABADO EN ANODIZADO INOX MATE</b> MATT STAINLESS STEEL ANODIZED FINISH		92	<b>ACABADO ESPECIAL 02</b> SPECIAL FINISH 02
	94	<b>ACABADO EN PINTURA LÍQUIDA</b> LIQUID PAINT FINISH		93	<b>ACABADO ESPECIAL 03</b> SPECIAL FINISH 03

\* Consultenos disponibilidad y fecha de entrega.

\* Please contact us for availability and delivery date.

✉ [info@stac.es](mailto:info@stac.es)

# ÍNDICE DE ICONOS

## ICON INDEX

### » TIPOS DE VENTANA WINDOW TYPES

	<b>VENTANA PRACTICABLE</b> SIDE-HUNG WINDOW
	<b>VENTANA PRACTICABLE CON HOJA PASIVA</b> SIDE-HUNG WINDOW WITH PASSIVE SASH
	<b>VENTANA PRACTICABLE CON 3 O MÁS HOJAS</b> SIDE-HUNG WINDOW WITH 3 OR MORE SASHES
	<b>VENTANA OSCIOBATIENTE</b> TILT & TURN WINDOW
	<b>VENTANA PROYECTANTE</b> TOP-HUNG WINDOW
	<b>VENTANA CORREDERA</b> SLIDING WINDOW
	<b>VENTANA PRACTICABLE DE HOJA POLIGONAL</b> SIDE-HUNG WINDOW WITH POLYGONAL SASH
	<b>CONTRAVENTANA DE 1 HOJA</b> SINGLE SASH WINDOW SHUTTER

 EXT.	<b>VENTANA DE APERTURA EXTERIOR</b> OUTWARD OPENING WINDOW
 EXT.	<b>VENTANA DE APERTURA EXTERIOR CON HOJA PASIVA</b> OUTWARD OPENING WINDOW WITH PASSIVE SASH
 EXT.	<b>VENTANA DE APERTURA EXTERIOR CON 3 O MÁS HOJAS</b> OUTWARD OPENING WINDOW WITH 3 OR MORE SASHES
	<b>VENTANA OSCIOBATIENTE CON HOJA PASIVA</b> TILT & TURN WINDOW WITH PASSIVE SASH
	<b>VENTANA PROYECTANTE MURO CORTINA</b> CURTAIN WALL TOP-HUNG WINDOW
	<b>VENTANA ABATIBLE</b> BOTTOM-HUNG WINDOW
 EXT.	<b>VENTANA DE APERTURA EXTERIOR DE HOJA POLIGONAL</b> OUTWARD OPENING WINDOW WITH POLYGONAL SASH
	<b>CONTRAVENTANA DE 2 HOJAS</b> DOUBLE SASH WINDOW SHUTTER

### » TIPOS DE PUERTA DOOR TYPES

		<b>PUERTA DE 1 / 2 HOJAS</b> SINGLE / DOUBLE SASH DOOR
--	---	---

	<b>CORREDERA ELEVABLE</b> LIFT & SLIDE
---	---



### » MATERIALES MATERIALS

<b>AL</b>	<b>ALUMINIO</b> ALUMINIUM
<b>AC</b>	<b>ACERO</b> STEEL
<b>PA</b>	<b>POLIAMIDA</b> POLYAMIDE
<b>POM</b>	<b>POLIOXIMETILENO (ACETAL)</b> POLYOXYMETHYLENE (ACETAL)
<b>PP</b>	<b>POLIPROPILENO</b> POLYPROPYLENE

<b>ZM</b>	<b>ZAMAK</b> ZAMAK
<b>INX</b>	<b>ACERO INOXIDABLE</b> STAINLESS STEEL
<b>PE</b>	<b>POLIETILENO</b> POLYETHYLENE
<b>PVC</b>	<b>POLICLORURO DE VINILO</b> POLYVINYL CHLORIDE
<b>ABS</b>	<b>ACRILONITRILLO BUTADIENO ESTIRENO</b> ACRYLONITRILE BUTADIENE STYRENE

» TIPO DE CANAL GROOVE TYPE

	<b>CANAL EUROPEO</b> EURO GROOVE
	<b>CANAL CENTRADO</b> CENTRED GROOVE



	<b>CANAL 16</b> 16 GROOVE
	<b>SIN CANAL</b> WITHOUT GROOVE

» APERTURA PRACTICABLE SIDE-HUNG WINDOW OPENING

	<b>PRACTICABLE CON CIERRE AL MARCO</b> SIDE-HUNG WINDOW WITH LOCKING TO FRAME
--	--

	<b>PRACTICABLE CON CIERRE AL INVERSOR</b> SIDE-HUNG WINDOW WITH LOCKING TO INVERTER
---	--



» APERTURA OSCIOBATIENTE TILT & TURN WINDOW OPENING

	<b>OSCILOBATIENTE CON CIERRE AL MARCO</b> TILT & TURN WINDOW WITH LOCKING TO FRAME
	<b>OSCILOBATIENTE CON MANIOBRA LÓGICA</b> TILT-BEFORE-TURN WINDOW





	<b>OSCILOBATIENTE CON CIERRE AL INVERSOR</b> TILT & TURN WINDOW WITH LOCKING TO INVERTER
---	---



» MANO DEL PRODUCTO PRODUCT HAND

	<b>PRODUCTO VÁLIDO PARA APERTURA A DERECHAS</b> PRODUCT VALID FOR RIGHT-HAND OPENING
	<b>MONTADO A DERECHAS E INTERCAMBIABLE A IZQUIERDAS</b> PRE-MOUNTED FOR RIGHT-HAND & INTERCHANGEABLE TO LEFT-HAND
	<b>PRODUCTO AMBIDIESTRO</b> AMBIDEXTROUS PRODUCT

	<b>PRODUCTO VÁLIDO PARA APERTURA A IZQUIERDAS</b> PRODUCT VALID FOR LEFT-HAND OPENING
	<b>MONTADO A IZQUIERDAS E INTERCAMBIABLE A DERECHAS</b> PRE-MOUNTED FOR LEFT-HAND & INTERCHANGEABLE TO RIGHT-HAND
	<b>PRODUCTO AMBIDIESTRO PERO SUMINISTRADO SIN MONTAR</b> AMBIDEXTROUS PRODUCT BUT SUPPLIED UNMOUNTED

» APERTURAS VÁLIDAS VALID OPENINGS

	<b>PRACTICABLE</b> SIDE-HUNG OPENING
	<b>PRACTICABLE INTERCAMBIABLE A OSCIOBATIENTE</b> SIDE-HUNG OPENING INTERCHANGEABLE TO TILT & TURN OPENING
	<b>OSCILOBATIENTE INTERCAMBIABLE A PROYECTANTE</b> TILT & TURN OPENING INTERCHANGEABLE TO BOTTOM-HUNG OPENING
	<b>PRACTICABLE Y OSCIOBATIENTE</b> TILT & TURN AND SIDE-HUNG OPENING

	<b>OSCILOBATIENTE</b> TILT & TURN OPENING
	<b>OSCILOBATIENTE INTERCAMBIABLE A PRACTICABLE</b> TILT & TURN OPENING INTERCHANGEABLE TO SIDE-HUNG OPENING
	<b>PROYECTANTE INTERCAMBIABLE A OSCIOBATIENTE</b> BOTTOM-HUNG OPENING INTERCHANGEABLE TO TILT & TURN OPENING



## ÍNDICE DE ICONOS

### ICON INDEX

#### » FUNDA DE TRANSMISIÓN TRANSMISSION COVER



**EL PRODUCTO INCLUYE FUNDA DE TRANSMISIÓN**  
THE CREMONE INCLUDES TRANSMISSION COVER



**LA CREMONA NO INCLUYE FUNDA DE TRANSMISIÓN**  
THE CREMONE DOES NOT INCLUDE TRANSMISSION COVER

#### » MICROVENTILACIÓN MICROVENTILATION



**EL PRODUCTO PERMITE POSICIÓN DE VENTILACIÓN**  
THE PRODUCT ALLOWS VENTILATION POSITION



**EL PRODUCTO NO PERMITE POSICIÓN DE VENTILACIÓN**  
THE PRODUCT DOES NOT ALLOW VENTILATION POSITION

#### » HERRAJE EVO EVO HARDWARE



**EL PRODUCTO INCORPORA HERRAJE EVO-SOFT**  
THE PRODUCT INCORPORATES EVO-SOFT HARDWARE



**EL PRODUCTO INCORPORA HERRAJE EVO-SECURITY**  
THE PRODUCT INCORPORATES EVO-SECURITY HARDWARE

#### » SISTEMAS ELEVABLES LIFT & SLIDE SYSTEMS



**PRODUCTO VÁLIDO PARA EL SISTEMA DE HERRAJE LS200**  
PRODUCT VALID FOR LS200 HARDWARE SYSTEM



**PRODUCTO VÁLIDO PARA EL SISTEMA DE HERRAJE LS400**  
PRODUCT VALID FOR LS400 HARDWARE SYSTEM

#### » MÁQUINAS TFS TFS MACHINES



**PRODUCTO VÁLIDO PARA LA MÁQUINA TFS-01**  
PRODUCT VALID FOR TFS-01 MACHINE



**PRODUCTO VÁLIDO PARA LA MÁQUINA TFS-05**  
PRODUCT VALID FOR TFS-05 MACHINE



**PRODUCTO VÁLIDO PARA LA MÁQUINA TFS-02**  
PRODUCT VALID FOR TFS-02 MACHINE



**PRODUCTO VÁLIDO PARA LA MÁQUINA TFS-06**  
PRODUCT VALID FOR TFS-06 MACHINE



**PRODUCTO VÁLIDO PARA LA MÁQUINA TFS-04**  
PRODUCT VALID FOR TFS-04 MACHINE



**PRODUCTO VÁLIDO PARA LA MÁQUINA TFS-08**  
PRODUCT VALID FOR TFS-08 MACHINE





**SISTEMA DE FIJACIÓN FAST** FIXING SYSTEM

Dispone de la posibilidad de pedir el producto con el sistema de fijación rápida FAST incorporado. Ver instrucciones en el capítulo "cremonas y manillas", apartado "notas técnicas". Para pedir referencias con sistemas FAST debe añadirse una « F » antes del acabado (únicamente en aquellos productos en los que esté indicada esta posibilidad).

You have the possibility to order the product with the built-in FAST fixing system. See instructions in the chapter "cremones and handles", section "technical notes". To order references with the FAST system, you must add an « F » before the finish (only for those products where this possibility is indicated).





A0790	F	**
-------	---	----

» EMBALAJE PACKING

	<b>UNIDADES POR CAJA</b> UNITS PER BOX
	<b>METROS POR BOBINA</b> METRES PER REEL

	<b>UNIDADES POR CÁNULA</b> UNITS PER TUBE
---	--

» HERRAMIENTAS TOOLS

	<b>LLAVE ALLEN 2,5 mm</b> 2,5 mm ALLEN KEY
	<b>LLAVE ALLEN 3 mm</b> 3 mm ALLEN KEY
	<b>LLAVE ALLEN 4 mm</b> 4 mm ALLEN KEY
	<b>LLAVE ALLEN 5 mm</b> 5 mm ALLEN KEY
	<b>LLAVE ALLEN 6 mm</b> 6 mm ALLEN KEY

	<b>LLAVE TORX T30</b> T30 TORX KEY
	<b>REFERENCIA CON TORNILLOS PHILLIPS PH2</b> REFERENCE WITH PHILLIPS 2 SCREWS
	<b>REFERENCIA CON CUADRADILLO DE 7 mm</b> REFERENCE WITH 7 mm SPINDLE
	<b>REFERENCIA CON CUADRADILLO DE 8 mm</b> REFERENCE WITH 8 mm SPINDLE
	<b>REFERENCIA CON CUADRADILLO DE 10 mm</b> REFERENCE WITH 10 mm SPINDLE

## CONSIDERACIONES

### CONSIDERATIONS

---



#### DEPARTAMENTO TÉCNICO CUALIFICADO

QUALIFIED TECHNICAL DEPARTMENT

---

Disponemos de un departamento técnico cualificado que está a su disposición para cualquier consulta. Si no ha encontrado lo que buscaba póngase en contacto con nosotros a través del correo [info@stac.es](mailto:info@stac.es) o del número de teléfono **(+34) 981 817 036**. Estudiaremos una solución adaptada a sus necesidades. Dispone de una versión online en formato pdf del catálogo que podrá descargarse y consultar en el apartado de descargas de nuestra web.

We have a qualified technical department that is at your complete disposal for any query. If you have not found what you are looking for, please contact us by email at [info@stac.es](mailto:info@stac.es) or by telephone **(+34) 981 817 036**. We will study a solution adapted to your needs There is an online catalogue version in pdf format that can be downloaded and consulted in the downloads section of our website.



#### CONSIDERACIONES PREVIAS

PRELIMINARY CONSIDERATIONS

---

La información contenida en este catálogo tiene carácter orientativo y puede sufrir modificaciones. STAC no se hace responsable de cualquier error en la impresión de este catálogo así como del uso que, en todo caso, está dirigido a personas con formación técnica, quedando sujeto a su responsabilidad y criterio. Los productos disponen de documentación especializada por lo que si necesita más información no dude en solicitarla.

The information in this catalogue is for reference only and is subject to modification. STAC will not be responsible for any error in the printing of this catalogue. STAC is not responsible for the use of the information herein; it is meant for trained technical persons and its use their responsibility. The products have specialized documentation so if you need more information do not hesitate to request it.

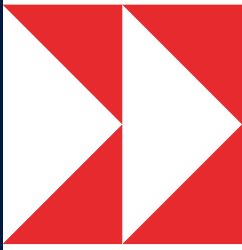

# 01

## **BISAGRAS** HINGES

- 28 **Bisagras de puerta ACRUX**  
ACRUX door hinges
- 32 **Bisagras de puerta ARIES**  
ARIES door hinges
- 40 **Bisagras de puerta TAURUS**  
TAURUS door hinges
- 42 **Bisagras de ventana CARINA**  
CARINA window hinges
- 48 **Bisagras de ventana NORMA**  
NORMA window hinges
- 52 **Bisagras de ventana 40 / 20**  
40 / 20 window hinges
- 56 **Bisagras de ventana HÉRCULES**  
HERCULES window hinges



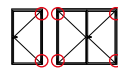

**ACRUX CE 2-PALAS**

2-LEAF ACRUX CE

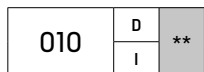

ANODIC

AL INX



allen3

allen6

TORX30

Bisagras regulables para perfiles de puerta con Canal Europeo.

- Regulación lateral de hasta  $\pm 1,2$  mm.
- Regulación vertical de hasta  $\pm 3$  mm con la referencia STC-MC-0011.
- Arandelas antifricción fabricadas en acetal (POM) para garantizar un comportamiento óptimo en términos de desgaste.

**ACRUX CE 2 PALAS**

- Carga máxima con 2 bisagras: **100 kg.**
- Carga máxima con 3 bisagras: **120 kg.**

**ACRUX CE 3 PALAS**

- Bisagra diseñada para su uso en puertas con alta frecuencia de uso, dimensiones límite,...
- Carga máxima con 2 bisagras: **120 kg.**
- Carga máxima con 3 bisagras: **150 kg.**

Adjustable hinges for doors with Euro Groove profiles.

- Lateral adjustment up to  $\pm 1.2$  mm.
- Vertical adjustment up to  $\pm 3$  mm with the reference STC-MC-0011.
- The anti-friction washers have been manufactured in acetal (POM) to guarantee optimum behaviour in terms of wear.

**2-LEAF ACRUX CE**

- Maximum load with 2 hinges: **100 kg.**
- Maximum load with 3 hinges: **120 kg.**

**3-LEAF ACRUX CE**

- Hinge designed for use on doors with high frequency of use, limiting dimensions,...
- Maximum load with 2 hinges: **120 kg.**
- Maximum load with 3 hinges: **150 kg.**

**ACRUX CE 3-PALAS**

3-LEAF ACRUX CE

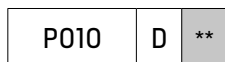

ANODIC

AL INX



allen3

allen6

TORX30

Disponible bisagra ACRUX C16 para perfiles de puerta de Canal 16 mm en página 332.

ACRUX C16 hinge available for 16 mm channel door profiles on page 332.

**KIT DE REGULACIÓN VERTICAL**

VERTICAL ADJUSTMENT KIT

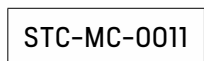

ZM INX

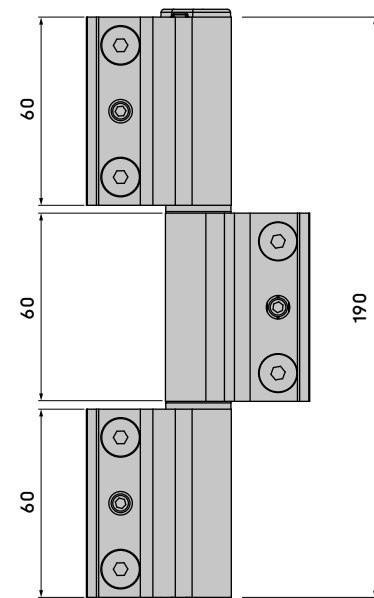
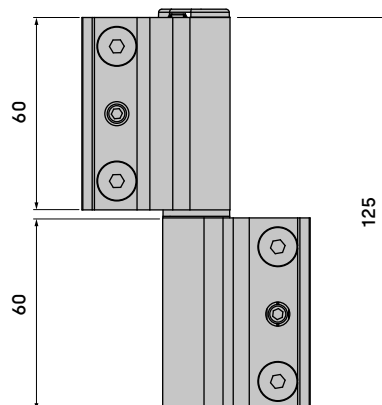

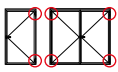



■ **14, 18 CANAL EUROPEO** » EJE TO  
EURO GROOVE » TO SHAFT

■ **REGULACIÓN ADJUSTMENT** »  $\pm 1,2$  mm  
allen 6 mm

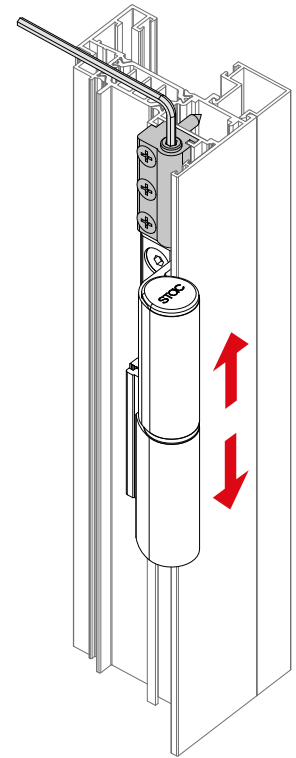
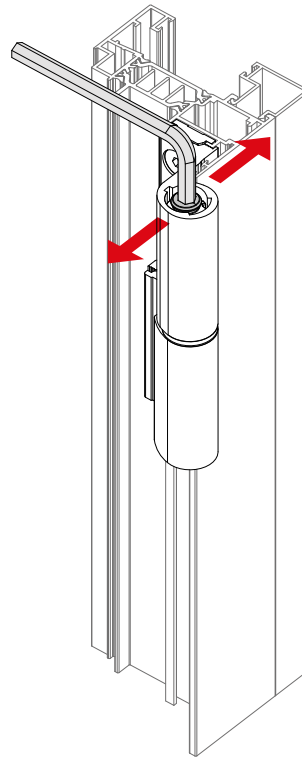
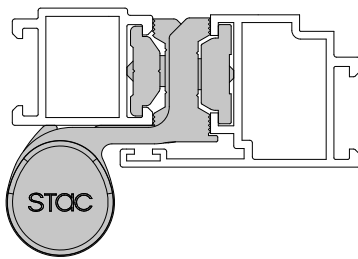
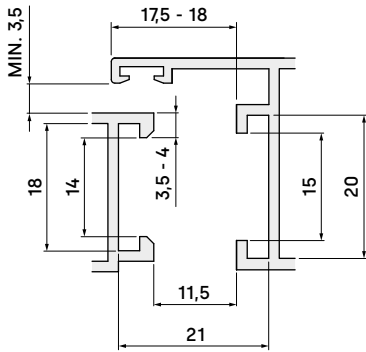
■ **REGULACIÓN ADJUSTMENT** »  $\pm 3$  mm  
allen 4 mm



» **RECOMENDACIONES DE USO** USAGE RECOMMENDATIONS \*

TIPO DE VIVIENDA	TYPE OF HOUSING	2 UNIDADES	UNITS	3 UNIDADES	UNITS
	<b>VIVIENDA UNIFAMILIAR</b> ONE-FAMILY HOUSE	100 kg		120 kg	
	<b>VIVIENDA MULTIFAMILIAR Y EDIFICIOS PÚBLICOS</b> MULTI-FAMILY HOUSING AND PUBLIC BUILDINGS	80 kg		100 kg	
	<b>CON CIERRAPUERTAS CON RETENEDOR</b> WITH DOOR CLOSER WITH RESTRICTOR	-		80 kg	
	<b>CON CIERRAPUERTAS SIN RETENEDOR</b> WITH DOOR CLOSER W/O RESTRICTOR	-		70 kg	

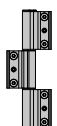
TIPO DE VIVIENDA	TYPE OF HOUSING	2 UNIDADES	UNITS	3 UNIDADES	UNITS
	<b>VIVIENDA UNIFAMILIAR</b> ONE-FAMILY HOUSE	120 kg		150 kg	
	<b>VIVIENDA MULTIFAMILIAR Y EDIFICIOS PÚBLICOS</b> MULTI-FAMILY HOUSING AND PUBLIC BUILDINGS	100 kg		130 kg	
	<b>CON CIERRAPUERTAS CON RETENEDOR</b> WITH DOOR CLOSER WITH RESTRICTOR	80 kg		110 kg	
	<b>CON CIERRAPUERTAS SIN RETENEDOR</b> WITH DOOR CLOSER W/O RESTRICTOR	70 kg		100 kg	

\* Ver ficha técnica para consultar la tabla de pesos máximos que soporta cada bisagra según las medidas de la puerta.

\* See technical data sheet to consult the table of maximum weights supported by each hinge according to the door dimensions.

# BISAGRAS ACRUX FR Canal Centrado

Central Groove ACRUX FR HINGES

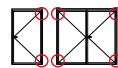

## ACRUX FR 2-PALAS

2-LEAF ACRUX FR

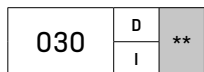

\*\*



AL INX



allen3

allen6

TORX30

Bisagras regulables para perfiles de puerta con Canal Centrado.

- Regulación lateral de hasta  $\pm 1,2$  mm.
- Regulación vertical de hasta  $\pm 3$  mm con la referencia STC-MC-0011.
- Arandelas antifricción fabricadas en acetal (POM) para garantizar un comportamiento óptimo en términos de desgaste.

### ACRUX FR 2 PALAS

- Carga máxima con 2 bisagras: **100 kg.**
- Carga máxima con 3 bisagras: **120 kg.**

### ACRUX FR 3 PALAS

- Bisagra diseñada para su uso en puertas con alta frecuencia de uso, dimensiones límite,...
- Carga máxima con 2 bisagras: **120 kg.**
- Carga máxima con 3 bisagras: **150 kg.**

Adjustable hinges for doors with Central Groove profiles.

- Lateral adjustment up to  $\pm 1.2$  mm.
- Vertical adjustment up to  $\pm 3$  mm with the reference STC-MC-0011.
- The anti-friction washers have been manufactured in acetal (POM) to guarantee optimum behaviour in terms of wear.

### 2-LEAF ACRUX FR

- Maximum load with 2 hinges: **100 kg.**
- Maximum load with 3 hinges: **120 kg.**

### 3-LEAF ACRUX FR

- Hinge designed for use on doors with high frequency of use, limiting dimensions,...
- Maximum load with 2 hinges: **120 kg.**
- Maximum load with 3 hinges: **150 kg.**

## ACRUX FR 3-PALAS

3-LEAF ACRUX FR

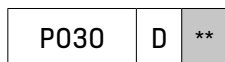

\*\*



AL INX



allen3

allen6

TORX30

Disponible bisagra ACRUX C16 para perfiles de puerta de Canal 16 mm en página 332.

ACRUX C16 hinge available for 16 mm channel door profiles on page 332.

## KIT DE REGULACIÓN VERTICAL

VERTICAL ADJUSTMENT KIT

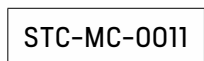

ZM INX

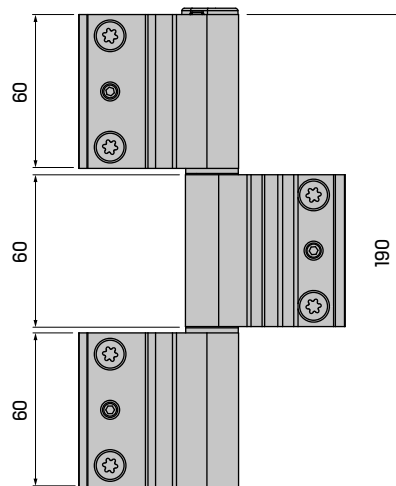
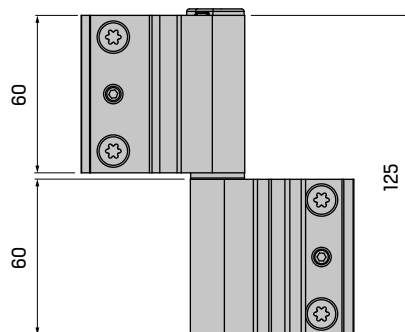



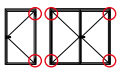

■ **CANAL CENTRADO**  
CENTRAL GROOVE

■ **REGULACIÓN ADJUSTMENT** »  $\pm 1,2$  mm  
allen 6 mm

■ **REGULACIÓN ADJUSTMENT** »  $\pm 3$  mm  
allen 4 mm

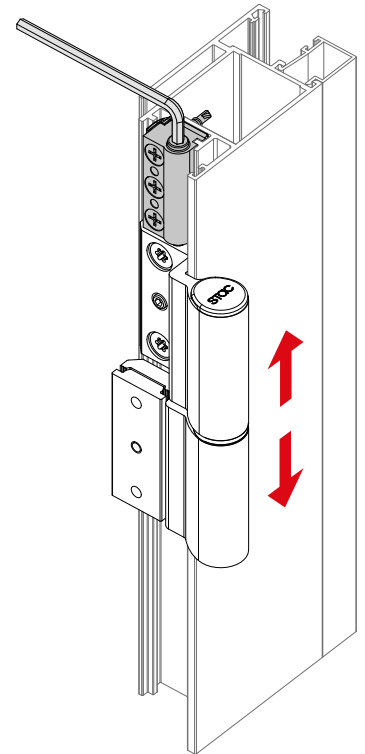
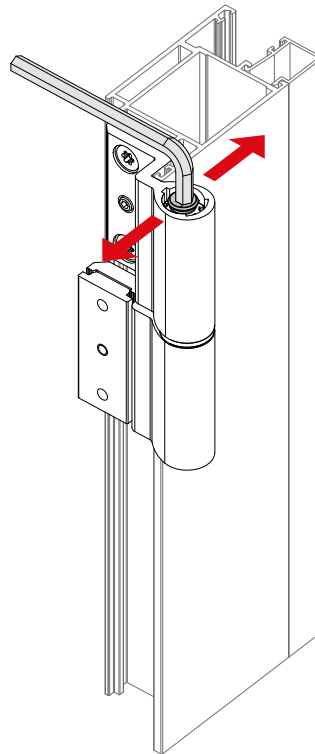
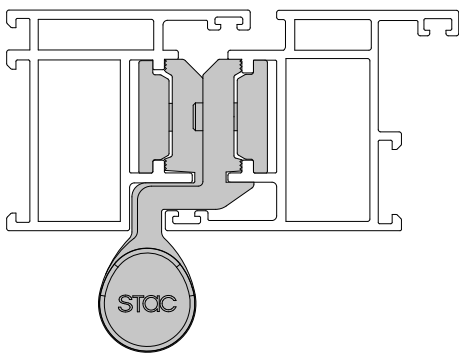
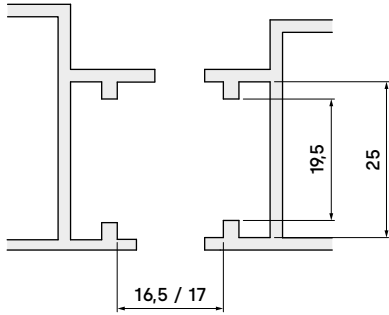

» **RECOMENDACIONES DE USO** USAGE RECOMMENDATIONS \*

TIPO DE VIVIENDA	TYPE OF HOUSING	2 UNIDADES	UNITS	3 UNIDADES	UNITS
	<b>VIVIENDA UNIFAMILIAR</b> ONE-FAMILY HOUSE	100 kg		120 kg	
	<b>VIVIENDA MULTIFAMILIAR Y EDIFICIOS PÚBLICOS</b> MULTI-FAMILY HOUSING AND PUBLIC BUILDINGS	80 kg		100 kg	
	<b>CON CIERRAPUERTAS CON RETENEDOR</b> WITH DOOR CLOSER WITH RESTRICTOR	-		80 kg	
	<b>CON CIERRAPUERTAS SIN RETENEDOR</b> WITH DOOR CLOSER W/O RESTRICTOR	-		70 kg	

TIPO DE VIVIENDA	TYPE OF HOUSING	2 UNIDADES	UNITS	3 UNIDADES	UNITS
	<b>VIVIENDA UNIFAMILIAR</b> ONE-FAMILY HOUSE	120 kg		150 kg	
	<b>VIVIENDA MULTIFAMILIAR Y EDIFICIOS PÚBLICOS</b> MULTI-FAMILY HOUSING AND PUBLIC BUILDINGS	100 kg		130 kg	
	<b>CON CIERRAPUERTAS CON RETENEDOR</b> WITH DOOR CLOSER WITH RESTRICTOR	80 kg		110 kg	
	<b>CON CIERRAPUERTAS SIN RETENEDOR</b> WITH DOOR CLOSER W/O RESTRICTOR	70 kg		100 kg	

\* Ver ficha técnica para consultar la tabla de pesos máximos que soporta cada bisagra según las medidas de la puerta.

\* See technical data sheet to consult the table of maximum weights supported by each hinge according to the door dimensions.

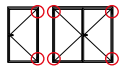

**ARIES T 2-PALAS**  
2-LEAF ARIES T

010T2	40	**
	60	
	66	
	80	
	93	



Bisagras universales con regulación milimétrica para perfiles de puerta.

- Regulación milimétrica en 3 dimensiones e independientes entre ellas.
- Sistemas de fijación: contraplacas de fijación tradicional y fijación directa al perfil a través de tornillos.
- Bisagras compatibles con aperturas interiores como exteriores.
- Bisagras compatibles con perfiles cuadrados estándar y rectangulares.
- Plantilla de taladrado regulable que facilita el mecanizado de los perfiles.
- Las bisagras tienen disponibles calzos para series con resalte.

Universal door hinges that allow millimetric adjustment.

- Milimetric adjustment in 3 dimensions and independent of each other.
- Fixing systems: counterplates for traditional fixing and direct fixing to the profile with screws.
- The hinges are compatible with both inward and outward openings.
- The hinges are compatible with standard square and rectangular profiles.
- Adjustable drilling template to facilitate profile machining.
- The hinges are available with shims for series with projections.

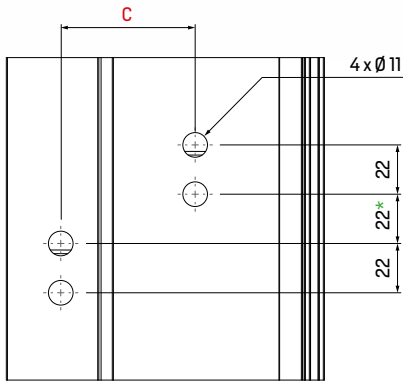

\* PARA LA REFERENCIA 010T240 LA DISTANCIA ES DE 20 mm  
FOR REFERENCE 010T240 THE DISTANCE IS 20 mm

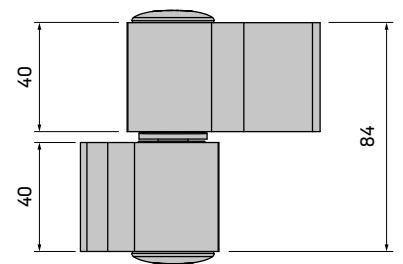

» **SISTEMAS DE FIJACIÓN COMPATIBLES** COMPATIBLE FIXING SYSTEMS

<b>A05KT2</b>	<b>FIJACIÓN TRADICIONAL CON CONTRAPLACAS ECO</b> TRADITIONAL FIXING WITH ECO COUNTERPLATES	
<b>A05KT2-L40</b>	<b>FIJACIÓN TRADICIONAL CON CONTRAPLACAS ECO L40</b> TRADITIONAL FIXING WITH ECO L40 COUNTERPLATES	PAG. 34
<b>P05KT2</b>	<b>FIJACIÓN TRADICIONAL CON CONTRAPLACAS RPT</b> TRADITIONAL FIXING WITH RPT COUNTERPLATES	
<b>0505041</b>	<b>FIJACIÓN RÁPIDA DIRECTA AL PERFIL Ø12 x 50 mm</b> QUICK FIXING DIRECTLY TO THE PROFILE Ø12 x 50 mm	PAG. 35
<b>0505042</b>	<b>FIJACIÓN RÁPIDA DIRECTA AL PERFIL Ø12 x 60 mm</b> QUICK FIXING DIRECTLY TO THE PROFILE Ø12 x 60 mm	

REF.		A	B	C
010T240	**	20	20	40
010T260	**	20	40	60
010T266	**	20	46,5	66,5
010T280	**	40	40	80
010T293	**	46,5	46,5	93

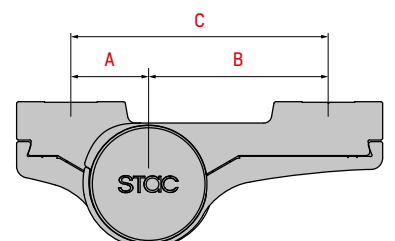

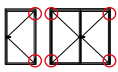

Universal door hinges that allow millimetric adjustment.

- Ideal for large, high weight and heavy duty doors.
- Milimetric adjustment in 3 dimensions and independent of each other.
- Fixing systems: counterplates for traditional fixing and direct fixing to the profile with screws.
- The hinges are compatible with both inward and outward openings.
- Adjustable drilling template to facilitate profile machining.
- The hinges are available with shims for series with projections.
- Hinges tested to 1,000,000 cycles with a load of 100 kg according to report number 16 /12559-1551.

Bisagras universales con regulación milimétrica para perfiles de puerta.

- Ideales para puertas de gran tamaño, peso elevado y utilización intensiva.
- Regulación milimétrica en 3 dimensiones e independientes entre ellas.
- Sistemas de fijación: contraplacas de fijación tradicional y fijación directa al perfil a través de tornillos.
- Las bisagras son compatibles con aperturas interiores como exteriores.
- Plantilla de taladrado regulable que facilita el mecanizado de los perfiles.
- Las bisagras tienen disponibles calzos para series con resalte.
- Bisagras testadas a 1.000.000 de ciclos con carga de 100 kg según número de informe 16 /12559-1551.

**ARIES T 3-PALAS**

3-LEAF ARIES T



010T3	60	**
	66	
	80	
	93	

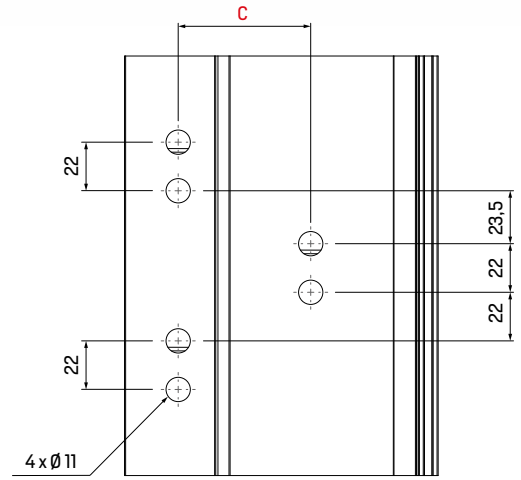
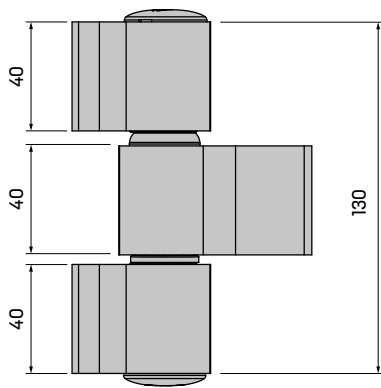

REF.		A	B	C
010T360	**	20	40	60
010T366	**	20	46,5	66,5
010T380	**	40	40	80
010T393	**	46,5	46,5	93

» **SISTEMAS DE FIJACIÓN COMPATIBLES** COMPATIBLE FIXING SYSTEMS

<b>A05KT3</b>	<b>FIJACIÓN TRADICIONAL CON CONTRAPLACAS ECO</b> TRADITIONAL FIXING WITH ECO COUNTERPLATES	
<b>A05KT3-L40</b>	<b>FIJACIÓN TRADICIONAL CON CONTRAPLACAS ECO L40</b> TRADITIONAL FIXING WITH ECO L40 COUNTERPLATES	PAG. 34
<b>P05KT3</b>	<b>FIJACIÓN TRADICIONAL CON CONTRAPLACAS RPT</b> TRADITIONAL FIXING WITH RPT COUNTERPLATES	
<b>0505041</b>	<b>FIJACIÓN RÁPIDA DIRECTA AL PERFIL Ø12 x 50 mm</b> QUICK FIXING DIRECTLY TO THE PROFILE Ø12 x 50 mm	PAG. 35
<b>0505042</b>	<b>FIJACIÓN RÁPIDA DIRECTA AL PERFIL Ø12 x 60 mm</b> QUICK FIXING DIRECTLY TO THE PROFILE Ø12 x 60 mm	

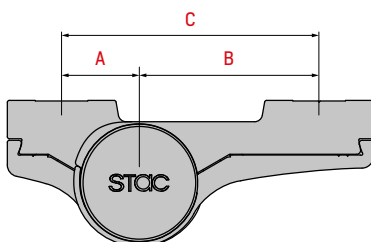

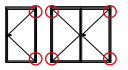

**KITS DE FIJACIÓN ECO**  
ECO FIXING KITS

<b>A05KT2</b>	<b>ARIES T 2 PALAS 2-LEAF</b>	AL INX
<b>A05KT3</b>	<b>ARIES T 3 PALAS 3-LEAF</b>	AC allen6

10



Kits de fijación para bisagras de puerta ARIES T con tornillos autocentrantes.

Fixing kits for ARIES T door hinges with self-centering screws.

**Kits de fijación ECO**

- Los agujeros se han centrado longitudinalmente en la pieza, por lo que no tienen posición predeterminada.
- Los kits L40 son válidos para series con resalte mediante la instalación del calzo de fijación tradicional 010CS.

**ECO fixing kits**

- The holes are centred longitudinally in the piece and therefore have no predetermined position.
- The L40 kits are suitable for series with step by means of the installation of the 010CS traditional fixing shim.

**Kits de fijación RPT**

- Las contraplacas en poliamida proporcionan un mayor aislamiento.
- Kits recomendados para su uso en perfiles con rotura de puente térmico.
- Diseño de las contraplacas simplificado disminuyendo el tiempo de montaje y obteniendo mayor sencillez de uso.

**RPT fixing kits**

- The backplates are made of polyamide, providing greater insulation.
- Kits recommended for use in profiles with thermal break.
- Simplified design of the counterplates, reducing installation time and making them easier to use.

**KITS DE FIJACIÓN ECO L40**  
ECO L40 FIXING KITS

<b>A05KT2-L40</b>	<b>ARIES T 2 PALAS 2-LEAF</b>	AL INX
<b>A05KT3-L40</b>	<b>ARIES T 3 PALAS 3-LEAF</b>	AC allen6

10

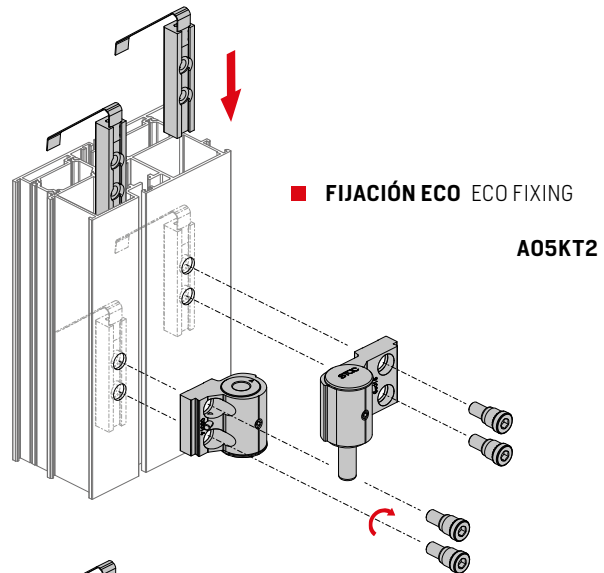

**KITS DE FIJACIÓN RPT**  
RPT FIXING KITS

<b>P05KT2</b>	<b>ARIES T 2 PALAS 2-LEAF</b>	AC PA
<b>P05KT3</b>	<b>ARIES T 3 PALAS 3-LEAF</b>	INX allen6

10

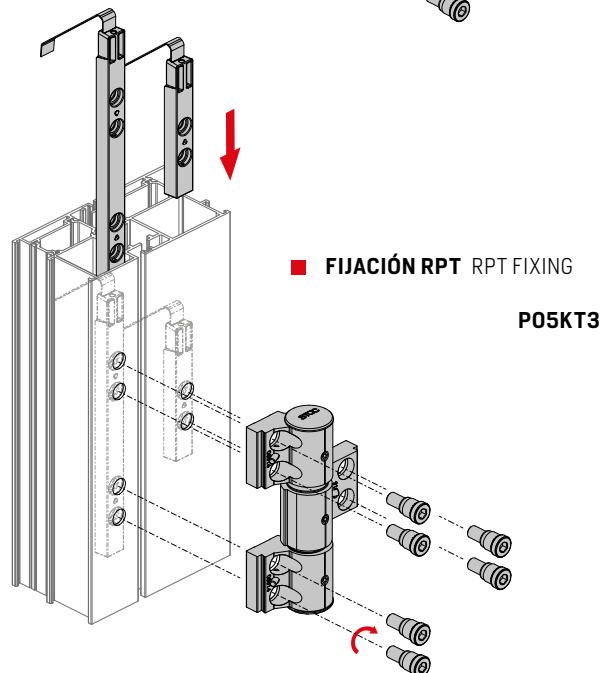

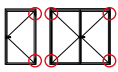

Fixing kits for ARIES T door hinges.

**Quick fixing screws**

- The quick fixing screws are valid for series with double chamber and with walls  $\geq 1.6$  mm.
- The fixing screws are made of steel with zinc-plated finish and are supplied in  $\varnothing 12$  mm diameter in lengths of 50 or 60 mm.

**Self-centering screws**

- Self-centering fixing screws for ECO and RPT counterplates.
- The self-centering screws have a greater hexagonal depth. This allows a higher torque to be applied without passing the screw heads.
- The M8 screws are supplied in lengths of 28 or 38 mm.

Kits de fijación para bisagras ARIES T.

**Tornillos de fijación rápida**

- Los tornillos son válidos para series que dispongan de doble cámara y con paredes  $\geq 1,6$  mm.
- Los tornillos están fabricados en acero con acabado zincado y se suministran con diámetro  $\varnothing 12$  mm en longitudes de 50 o 60 mm.

**Tornillos autocentrantes**

- Tornillos de fijación autocentrantes para las contraplacas ECO / RPT.
- Los tornillos tienen mayor profundidad de huella hexagonal lo que permite aplicar mayor par de apriete sin que se pasen las cabezas de los tornillos.
- Los tornillos de M8 se suministran en longitudes de 28 o 38 mm.

**TORNILLOS DE FIJACIÓN RÁPIDA**  
QUICK FIXING SCREWS

AC  $\varnothing 12 \times 50$  mm **0505041**

allen6  $\varnothing 12 \times 60$  mm **0505042**



200

**TORNILLOS AUTOCENTRANTES (ECO / RPT)**  
SELF-CENTERING SCREWS (ECO / RPT)

AC M8 x 28 mm **0505089**

allen6 M8 x 38 mm **0505090**



100

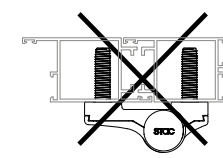
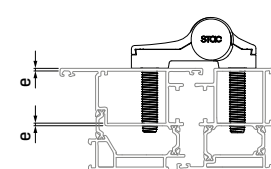
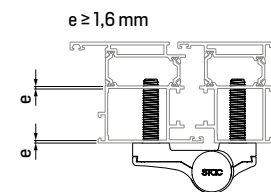
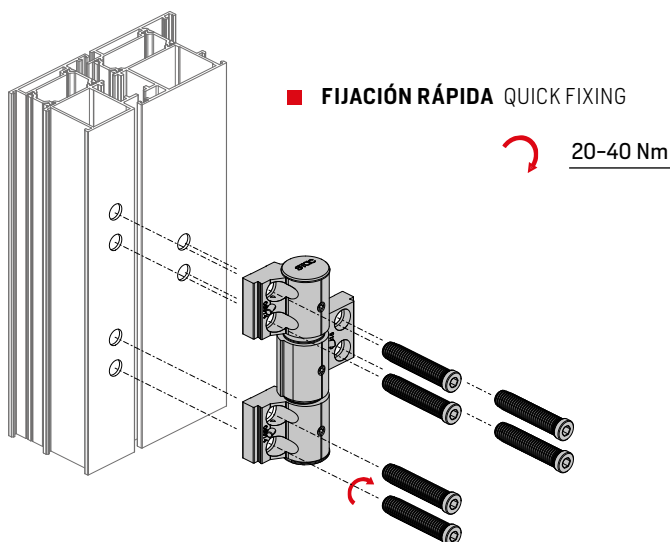
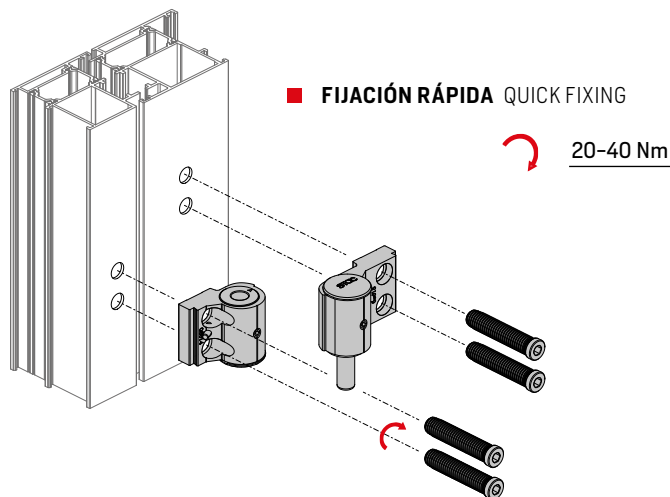

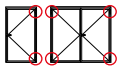

**CALZOS PARA FIJACIÓN RÁPIDA**  
SHIMS FOR QUICK FIXING

010TS	07	**
	08	
	10	

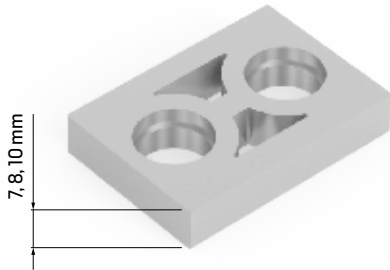

Calzos para fijación de bisagras ARIES T en series de perfil con resalte.

- Los calzos están disponibles en distintas medidas y acabados.

**Calzos 010TS**

- Calzos de aluminio para fijación rápida al perfil por medio de tornillos de acero con ref. 0505041 / 0505042.

**Calzos 010CS**

- Calzos de aluminio con casquillos para fijación tradicional al perfil mediante contraplacas ECO-L40.
- El montaje de los calzos se realiza a través de los tornillos con ref. 0505090 o a través de los kits de fijación ECO L40.

Shims for fixing ARIES T door hinges in profile series with step.

- The shims are available in different sizes and finishes.

**010TS shims**

- Aluminium shims for quick fixing to the profile by means of steel screws with ref. 0505041 / 0505042.

**010CS shims**

- Aluminium shims with bushes for traditional fixing to the profile by means of ECO-L40 counterplates.
- The shims are assembled using screws ref. 0505090 or using the ECO L40 fixing kits.

**CALZOS PARA FIJACIÓN TRADICIONAL (ECO / RPT)**  
SHIMS FOR TRADITIONAL FIXING (ECO / RPT)

010CS	07	**
	08	
	10	

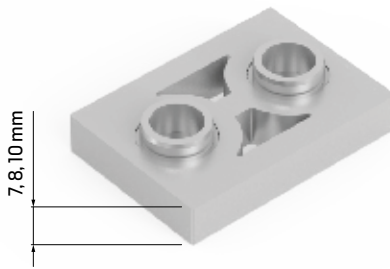

QUICK FIXING **FIJACIÓN RÁPIDA** ■

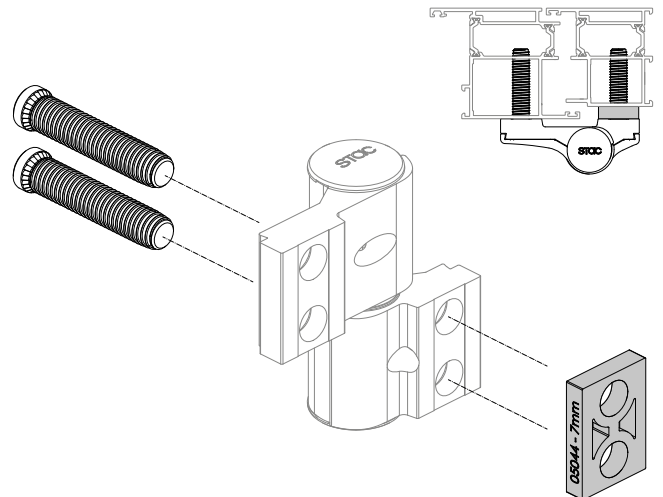

» **010TS FIJACIONES COMPATIBLES** COMPATIBLE FIXING SYSTEMS

<b>0505041</b>	<b>FIJ. RÁPIDA DIRECTA AL PERFIL Ø12 x 50 mm</b> QUICK FIXING DIRECTLY TO THE PROFILE Ø12 x 50 mm	PAG. 35
<b>0505042</b>	<b>FIJ. RÁPIDA DIRECTA AL PERFIL Ø12 x 60 mm</b> QUICK FIXING DIRECTLY TO THE PROFILE Ø12 x 60 mm	

» **010CS FIJACIONES COMPATIBLES** COMPATIBLE FIXING SYSTEMS

<b>A05KT2-L40</b>	<b>FIJ. TRADICIONAL CON CONTRAPLACAS ECO L40</b> TRADITIONAL FIXING WITH ECO L40 COUNTERPLATES	PAG. 34
<b>A05KT3-L40</b>	<b>FIJ. TRADICIONAL CON CONTRAPLACAS ECO L40</b> TRADITIONAL FIXING WITH ECO L40 COUNTERPLATES	
<b>0505090</b>	<b>TORNILLOS CENTRADORES M8 x 38 mm</b> SELF-CENTERING SCREWS M8 x 38 mm	PAG. 35

TRADITIONAL FIXING **FIJACIÓN TRADICIONAL** ■

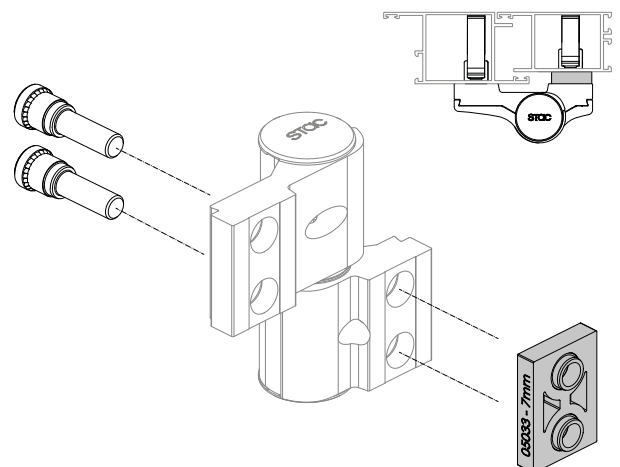



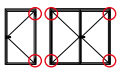

Adjustable template that facilitates and optimises the drilling of the profiles.

- The drilling template adapts to all available ARIES hinge sizes.
- The drilling template is supplied with bolts to fit 4, 5, 6 and 8 mm coplanar profile traces.
- Instruction sheet available.

Plantilla regulable que facilita y optimiza el taladrado de los perfiles.

- La plantilla se adapta a todas las medidas de bisagras ARIES disponibles.
- Se suministra con bulones para adaptarse a huellas de perfil coplanarios de 4, 5, 6 y 8 mm.
- Disponible hoja de instrucciones.

**PLANTILLA DE TALADRADO REGULABLE**  
ADJUSTABLE DRILLING TEMPLATE

AL AC

P-010-01

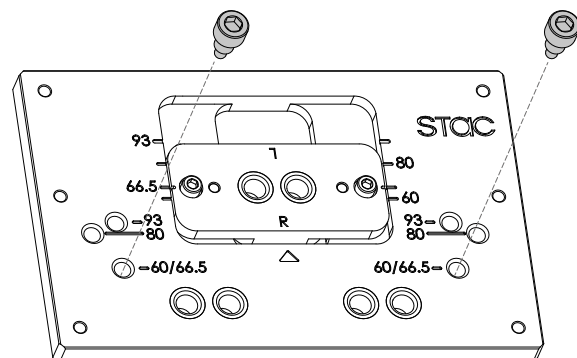
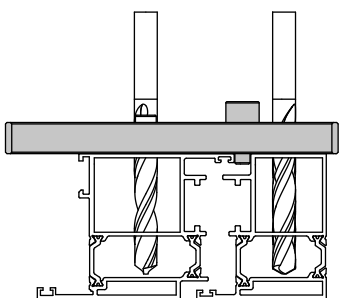
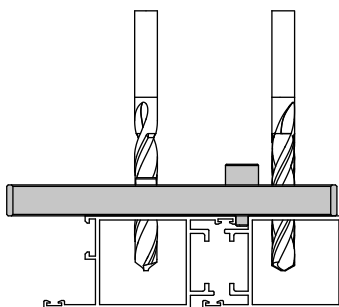
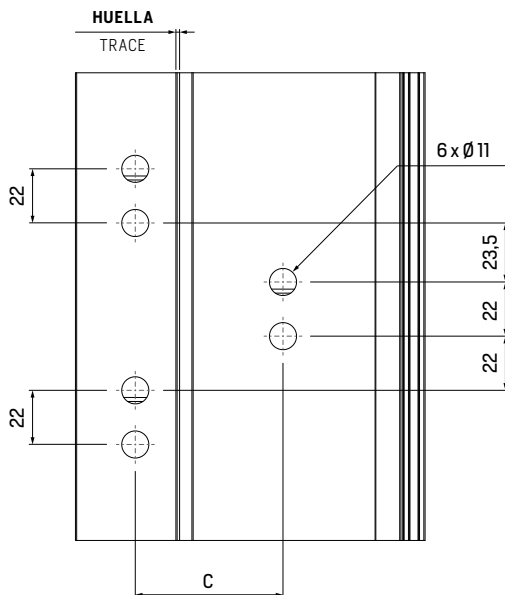

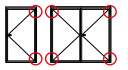

» REGULACIONES ADJUSTMENTS

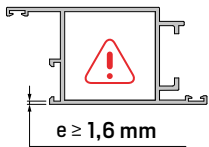
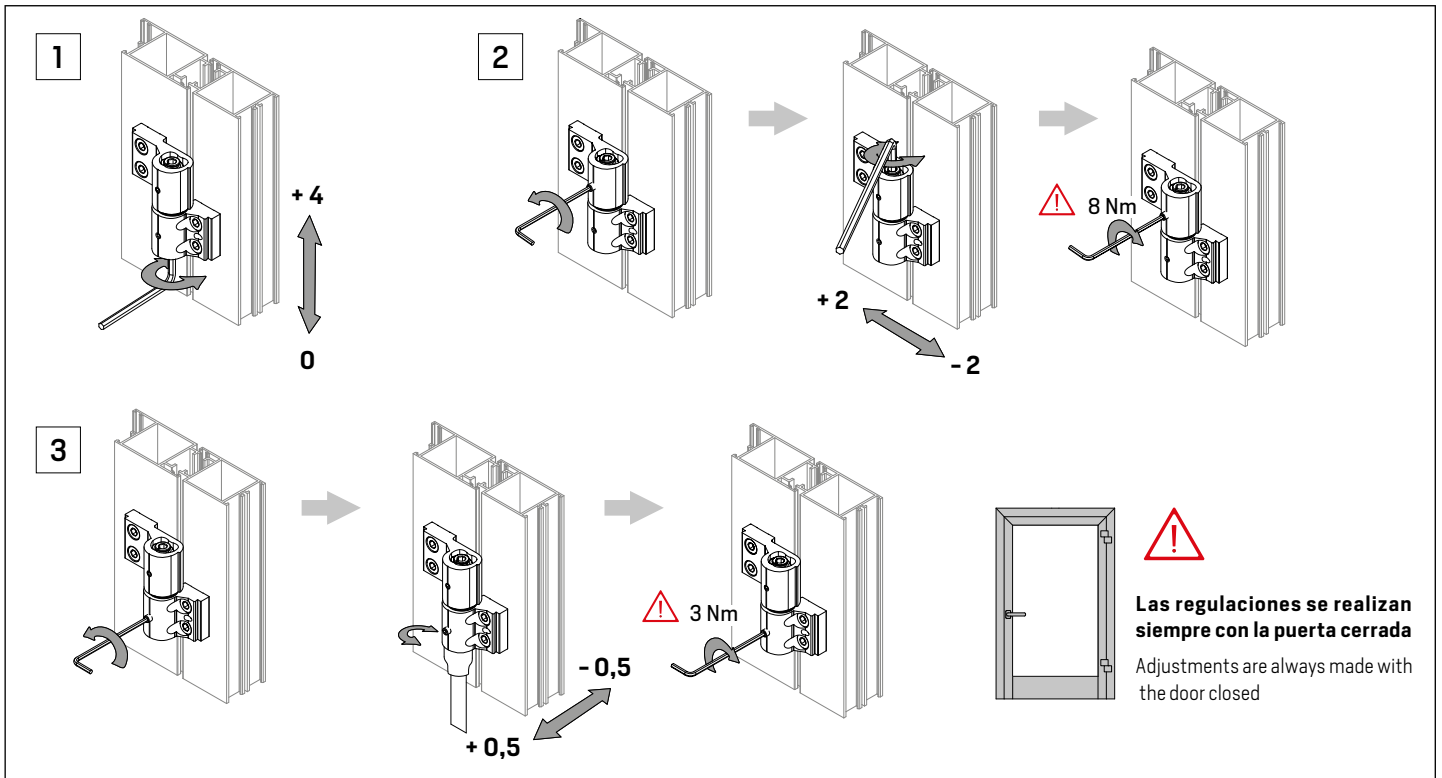

Las recomendaciones de uso se aplican para un espesor de perfil  $\geq 1,6$  mm. Si el espesor es menor, consulte con el departamento técnico de STAC.

The recommendations for use apply for a profile thickness  $\geq 1.6$  mm. If the thickness is less, please consult STAC's technical department.

The recommendations for use apply for a profile thickness  $\geq 1.6$  mm. If the thickness is less, please consult STAC's technical department.

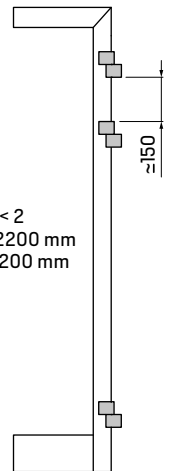
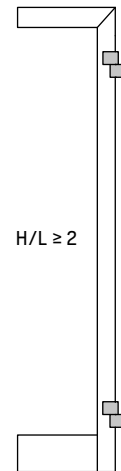
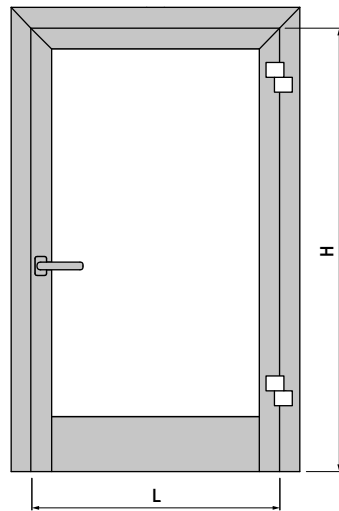

» RECOMENDACIONES DE USO USAGE RECOMMENDATIONS

TIPO DE VIVIENDA TYPE OF HOUSING	2 UNIDADES UNITS	3 UNIDADES UNITS
<b>VIVIENDA UNIFAMILIAR</b> ONE-FAMILY HOUSE	160 kg	180 kg
<b>VIVIENDA MULTIFAMILIAR Y EDIFICIOS PÚBLICOS</b> MULTI-FAMILY HOUSING AND PUBLIC BUILDINGS	140 kg	160 kg
<b>CON CIERRAPUERTAS CON RETENEDOR</b> WITH DOOR CLOSER WITH RESTRICTOR	100 kg	120 kg
<b>CON CIERRAPUERTAS SIN RETENEDOR</b> WITH DOOR CLOSER W/O RESTRICTOR	125 kg	150 kg



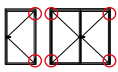

» **REGULACIONES** ADJUSTMENTS

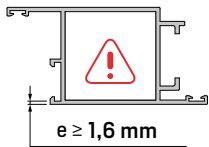
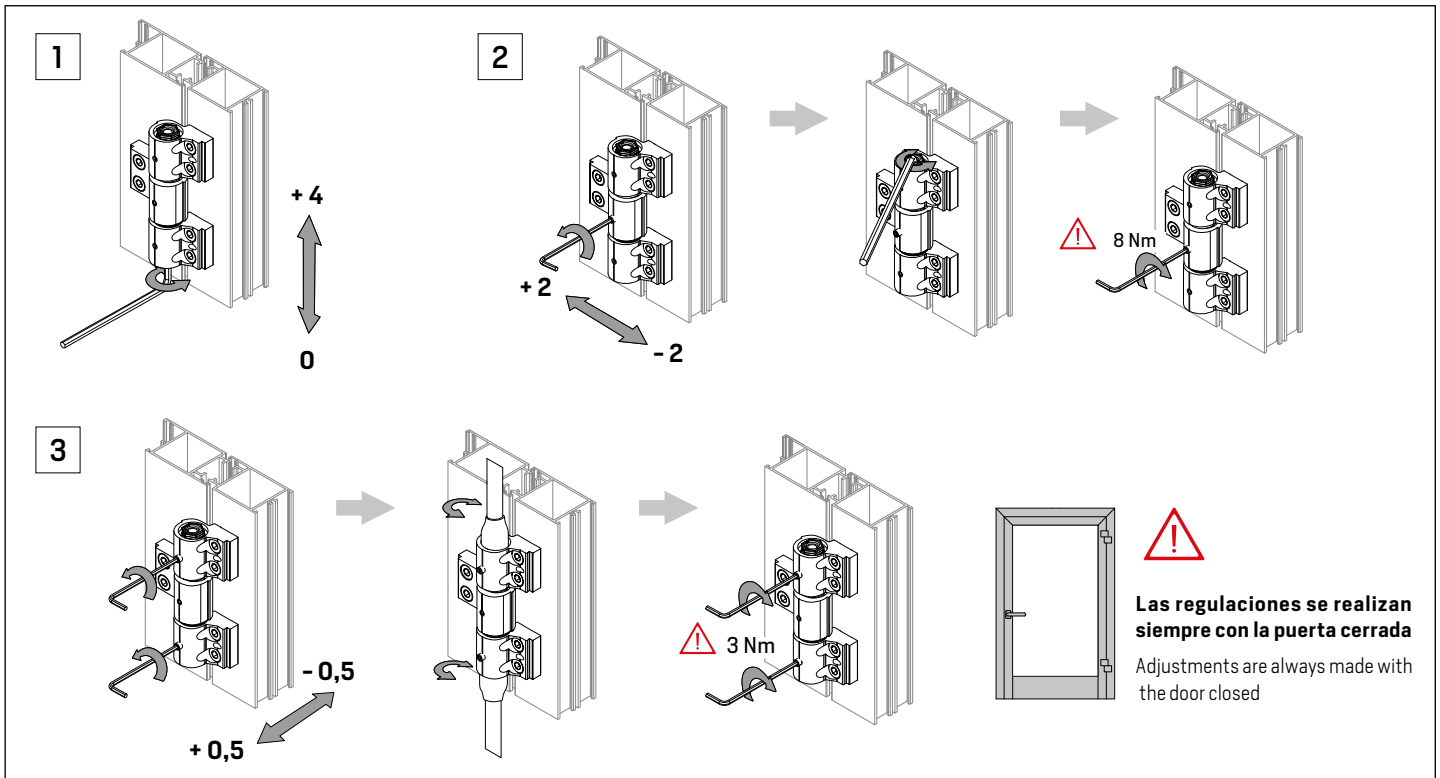

Las recomendaciones de uso se aplican para un espesor de perfil  $\geq 1,6$  mm.  
 Si el espesor es menor, consulte con el departamento técnico de STAC.

The recommendations for use apply for a profile thickness  $\geq 1.6$  mm.  
 If the thickness is less, please consult STAC's technical department.

The recommendations for use apply for a profile thickness  $\geq 1.6$  mm.  
 If the thickness is less, please consult STAC's technical department.

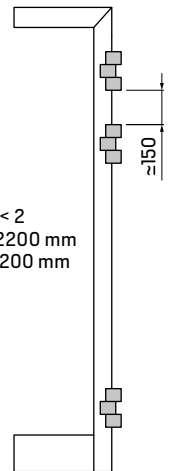
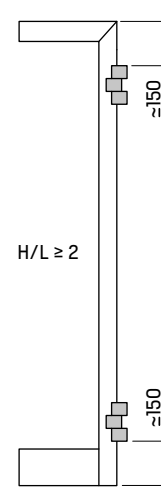
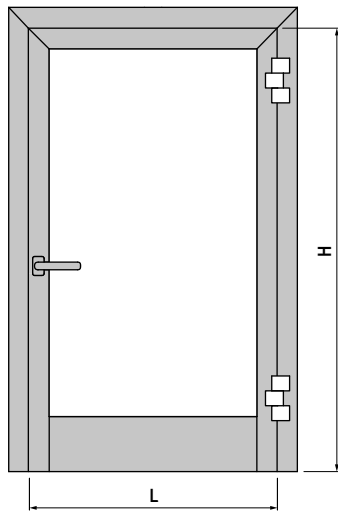

» **RECOMENDACIONES DE USO** USAGE RECOMMENDATIONS

TIPO DE VIVIENDA TYPE OF HOUSING	2 UNIDADES UNITS	3 UNIDADES UNITS
<b>VIVIENDA UNIFAMILIAR</b> ONE-FAMILY HOUSE	160 kg	180 kg
<b>VIVIENDA MULTIFAMILIAR Y EDIFICIOS PÚBLICOS</b> MULTI-FAMILY HOUSING AND PUBLIC BUILDINGS	150 kg	170 kg
<b>CON CIERRAPUERTAS CON RETENEDOR</b> WITH DOOR CLOSER WITH RESTRICTOR	120 kg	140 kg
<b>CON CIERRAPUERTAS SIN RETENEDOR</b> WITH DOOR CLOSER W/O RESTRICTOR	140 kg	160 kg

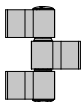

# BISAGRAS TAURUS

TAURUS HINGES

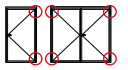

## TAURUS

TAURUS

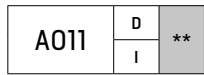

\*\*



AL INX

POM



allen3

TORX30

Bisagra regulable para perfiles de puerta con Canal Europeo.

- Instalación directa en el perfil sin necesidad de realizar ningún mecanizado.
- La bisagra incorpora un tornillo prisionero para evitar el deslizamiento.
- La bisagra se suministra con tapa de regulación y casquillo en acetal con clip mejorado.
- Regulación horizontal de  $\pm 1$  mm, incluso con la puerta instalada.
- Regulación vertical de hasta  $\pm 3$  mm con la referencia STC-MC-0011.
- La carga máxima con 2 o más bisagras es de 100 kg.

Adjustable hinge for doors with Euro Groove profiles.

- Direct installation on the profile without the need for any machining.
- The hinge incorporates a set screw to prevent slippage.
- The hinge is supplied with adjustment cap and acetal bushing with improved clip.
- Horizontal adjustment of  $\pm 1$  mm, even with the door installed.
- Vertical adjustment up to  $\pm 3$  mm with reference STC-MC-0011.
- Maximum load with 2 or more hinges is 100 kg.

## TAURUS desmontada

Disassembled TAURUS

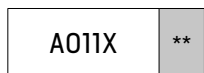

\*\*



## KIT DE REGULACIÓN VERTICAL

VERTICAL ADJUSTMENT KIT

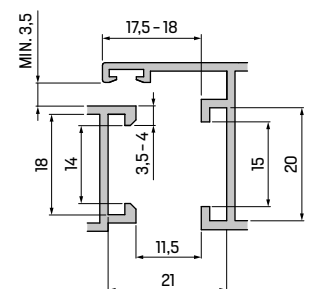
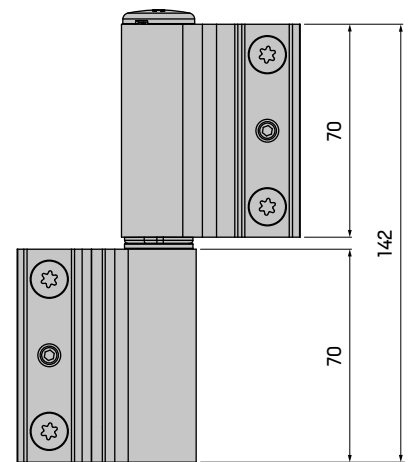
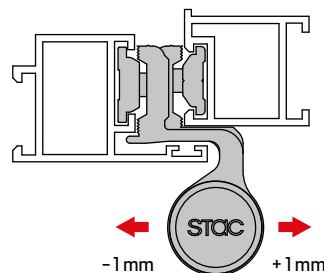
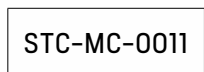

14, 18 CANAL EUROPEO » EJE 10  
EURO GROOVE » 10 SHAFT

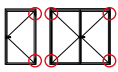

Adjustable hinge for doors with Euro Groove profiles.

- Hinge specially designed for large doors with high weight.
- Direct installation on the profile without the need for any machining.
- Horizontal adjustment of  $\pm 1$  mm, even with the door installed.
- Vertical adjustment up to  $\pm 3$  mm with reference STC-MC-0011.
- The hinge incorporates a ball bearing for smooth and silent turning.
- The kit consists of two hinges with adjustment and fixing elements.
- Maximum load with 2 or more hinges is 160 kg.

Bisagra regulable para perfiles de puerta con Canal Europeo.

- Bisagra diseñada para puertas de grandes dimensiones con peso elevado.
- Instalación directa en el perfil sin necesidad de realizar ningún mecanizado.
- Regulación horizontal de  $\pm 1$  mm, incluso con la puerta instalada.
- Regulación vertical de hasta  $\pm 3$  mm con la referencia STC-MC-0011.
- Incorpora un rodamiento de bolas que realiza un giro suave y silencioso.
- El kit está compuesto por dos bisagras con elementos de regulación y sujeción.
- La carga máxima con 2 o más bisagras es de 160 kg.

**TAURUS CLX**  
TAURUS CLX

\*\*



AL INX

POM



TORX 30

A011	D	**	-160
	I		



**FUNDA PARA TAURUS CLX**  
TAURUS CLX COVER

\*\*



ANODIC

AL



A011F	**	-160
-------	----	------

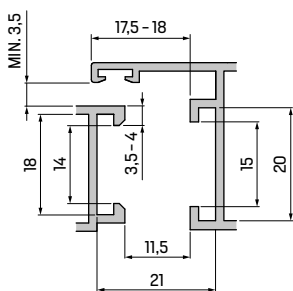
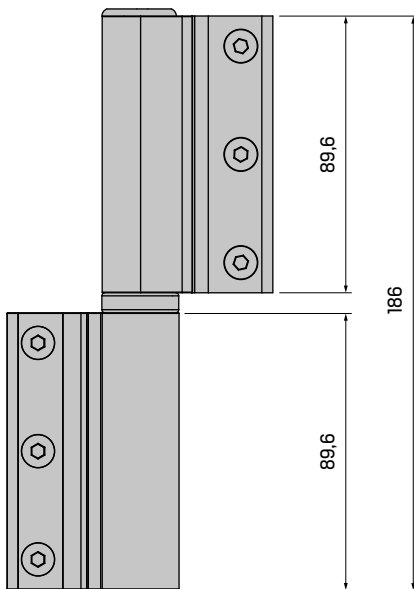

14, 18 CANAL EUROPEO » EJE 10  
EURO GROOVE » 10 SHAFT

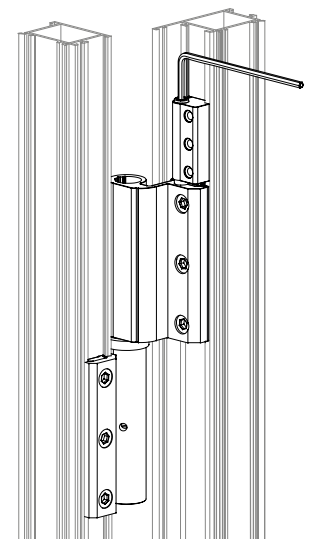
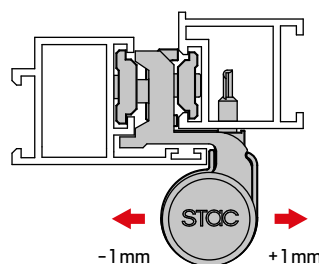

# BISAGRAS CARINA con contraplacas de zamak

CARINA HINGES with zamak counterplates

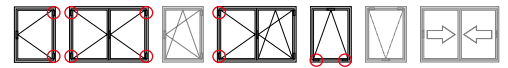

## CARINA con contraplacas de zamak

CARINA with zamak counterplates

019	D	**
	I	**

019	D	**	R
	I	**	

**Regulable**  
Adjustable

50



\*\*



AL ZM

PA INX



PH2

Bisagras de ventana con contraplacas de zamak para perfiles con Canal Europeo.

- Las contraplacas incorporan un tornillo prisionero para evitar el deslizamiento.
- El casquillo recubre el bulón de manera que queda aislado de la intemperie.
- Bisagras reversibles de dos cuerpos que se suministran montadas para su instalación a derechas o a izquierdas.
- Carga máxima con 2 bisagras: **60 kg.**
- Carga máxima con 3 bisagras: **75 kg.**

### Bisagra regulable CARINA

- La bisagra regulable dispone de un bulón excéntrico que permite regulación horizontal y de apriete.

Window hinges with zamak counterplates for Euro Groove profiles.

- The counterplates incorporate a set screw to prevent slippage.
- The bushing covers the bolt so that it is insulated from the weather.
- The two-body reversible hinges are supplied assembled for right-hand or left-hand installation.
- Maximum load with 2 hinges: **60 kg.**
- Maximum load with 3 hinges: **75 kg.**

### CARINA adjustable hinge

- The adjustable hinge has an eccentric pin for horizontal and tightening adjustment.

## CARINA desmontada con contraplacas de zamak

Disassembled CARINA with zamak counterplates

B019X	**
-------	----

B019X	**	R
-------	----	---

**Regulable**  
Adjustable

50

\*\*



### REGULACIONES ADJUSTMENTS » Allen 3

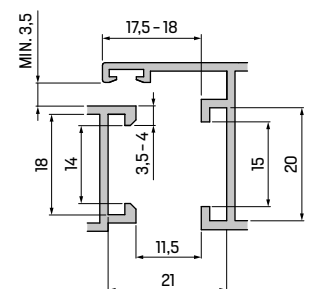
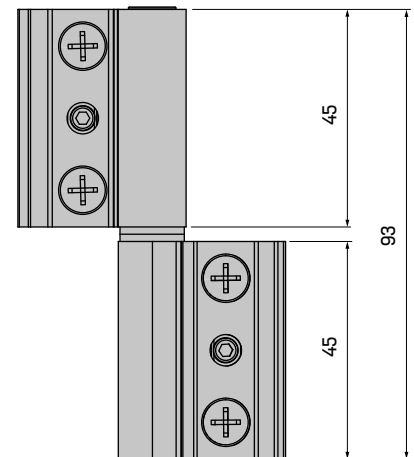
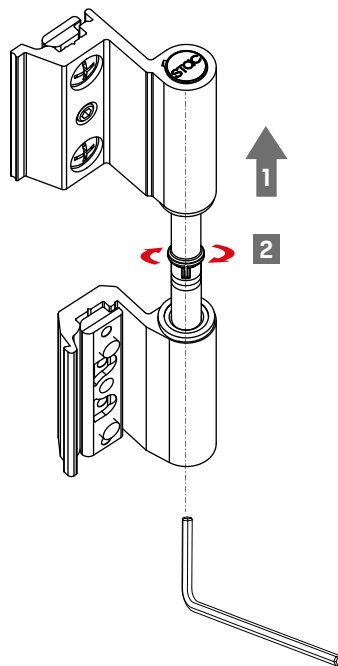
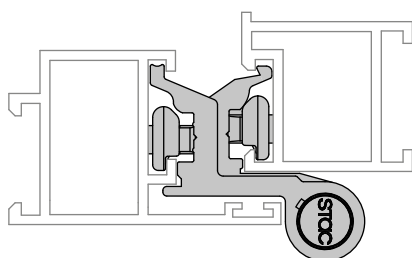
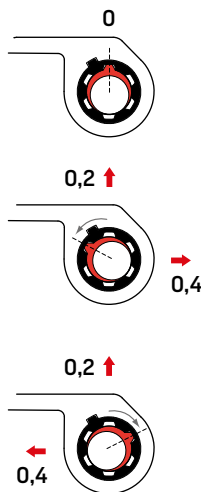

14, 18 CANAL EUROPEO » EJE 10  
EURO GROOVE » 10 SHAFT



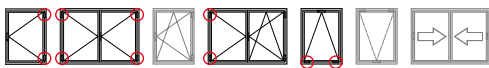

Window hinges with steel counterplates for Euro Groove profiles.

- They are provided with an stainless steel anti-slip counterplate that doubles the gripping capacity and improves the pre-assembly of the hinges.
- The bushing covers the bolt so that it is insulated from the weather.
- The two-body reversible hinges are supplied assembled for right-hand or left-hand installation.
- Maximum load with 2 hinges: **60 kg.**
- Maximum load with 3 hinges: **75 kg.**

**CARINA PLUS adjustable hinge**

- The adjustable hinge has an eccentric pin for horizontal and tightening adjustment.

Bisagras de ventana con contraplacas de acero para perfiles con Canal Europeo.

- Disponen de contraplaca antideslizamiento de INOX que permite duplicar la capacidad de agarre y mejora el pre-montaje de las bisagras.
- El casquillo recubre el bulón de manera que queda aislado de la intemperie.
- Bisagras reversibles de dos cuerpos que se suministran montadas para su instalación a derechas o a izquierdas.
- Carga máxima con 2 bisagras: **60 kg.**
- Carga máxima con 3 bisagras: **75 kg.**

**Bisagra regulable CARINA PLUS**

- La bisagra regulable dispone de un bulón excéntrico que permite regulación horizontal y de apriete.

**CARINA PLUS**  
CARINA PLUS



023	D	**
	I	

Regulable  
Adjustable

023	D	**	R
	I		



**CARINA PLUS desmontada**  
Disassembled CARINA PLUS



B023X	**
-------	----

Regulable  
Adjustable

B023X	**	R
-------	----	---

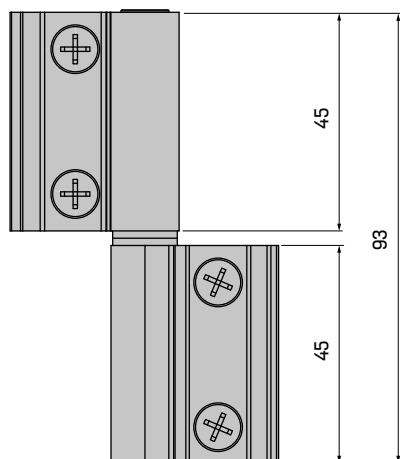

**REGULACIONES ADJUSTMENTS » Allen 3**

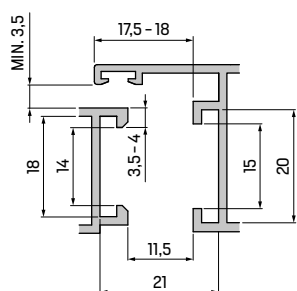
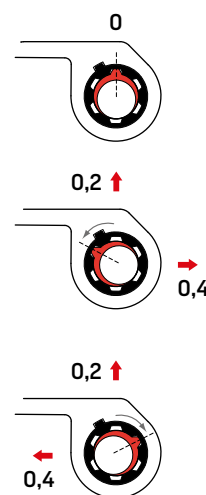
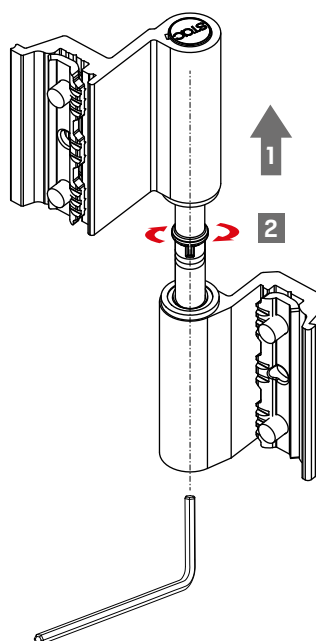

**14, 18 CANAL EUROPEO » EJE 10**  
EURO GROOVE » 10 SHAFT

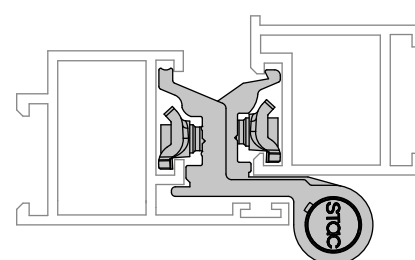

# BISAGRAS CARINA DE 3ª HOJA

3<sup>rd</sup> SASH CARINA HINGES

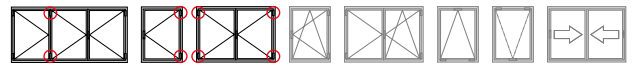

## CARINA DE 3ª HOJA

3<sup>rd</sup> SASH CARINA

014D \*\*

014D \*\* R

**Regulable**  
Adjustable

30



\*\*



AL INX

PA



PH2

Bisagras de ventana automontables de 3ª hoja para perfiles con Canal Europeo o coplanares.

- Las contraplacas incorporan un denta-do especial que evitan el deslizamiento.
- El casquillo recubre el bulón de manera que queda aislado de la intemperie.
- Las bisagras son compatibles con perfiles coplanares de Canal Europeo.
- Bisagras reversibles de dos cuerpos se suministran semimontadas para su instalación a derechas o a izquierdas.
- Carga máxima con 2 bisagras: **50 kg.**
- Carga máxima con 3 bisagras: **60 kg.**

### Bisagra regulable CARINA

- La bisagra regulable dispone de un bulón excéntrico que permite regulación horizontal y de apriete.

Self-assembly 3<sup>rd</sup> sash hinges for windows with Euro Groove profiles or coplanar profiles.

- The counterplates have special serrations to prevent slipping.
- The bushing covers the bolt so that it is insulated from the weather.
- The hinges are compatible with Euro Groove profiles.
- The hinges are two-part reversible and are supplied semi-assembled for right or left-handed installation.
- Maximum load with 2 hinges: **50 kg.**
- Maximum load with 3 hinges: **60 kg.**

### CARINA adjustable hinge

- The adjustable hinge has an eccentric pin for horizontal and tightening adjustment.

#### ■ REGULACIONES ADJUSTMENTS » Allen 3

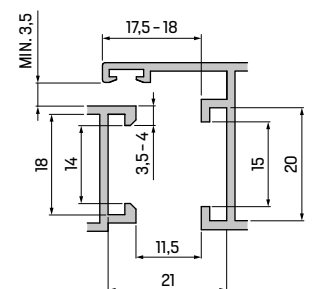
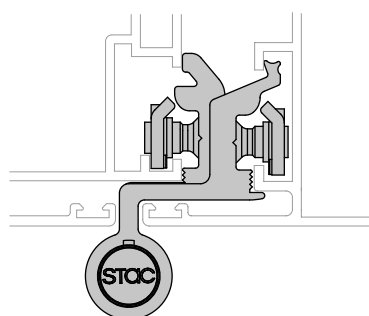
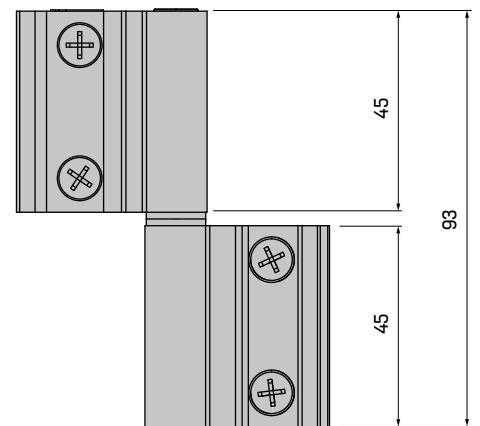
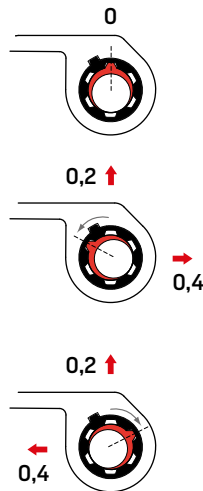
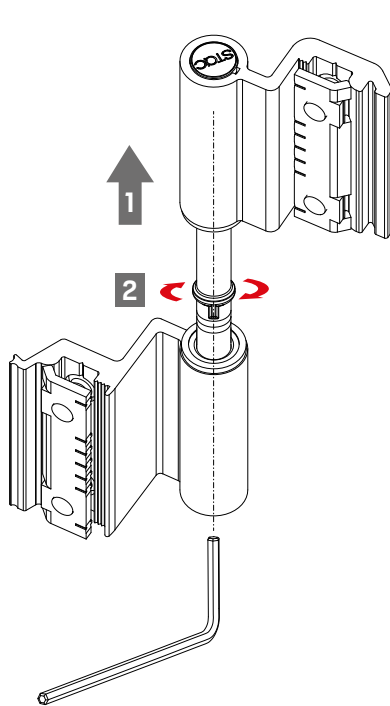

14, 18 CANAL EUROPEO » EJE 10  
EURO GROOVE » 10 SHAFT



## BISAGRAS CARINA DE 4ª HOJA

### 4th SASH CARINA HINGES

Self-assembly 4<sup>th</sup> sash hinges for windows with Euro Groove profiles.

- Direct installation on the profile without the need for any machining.
- The hinges allow horizontal adjustment of  $\pm 1$  mm.
- The hinge bushing is made of acetal to prevent wear and noise.
- For maximum loads of the leaf hinge refer to the technical data sheet.

Bisagras automontables de 4ª hoja para perfiles de ventana con Canal Europeo.

- Instalación directa en el perfil sin necesidad de realizar ningún mecanizado.
- Las bisagras permiten regulación horizontal de  $\pm 1$  mm.
- Casquillo en acetal para evitar el desgaste y los ruidos.
- Para cargas máximas de las bisagras de hoja consulte la ficha técnica.

## CARINA DE 4ª HOJA

### 4th SASH CARINA

\*\*



AL INX

POM



allen2,5

PH2

TORX30

018	D	**
	I	

20

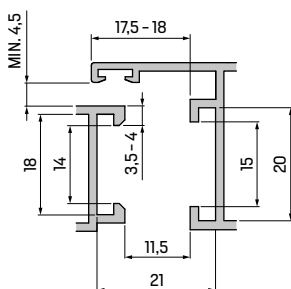
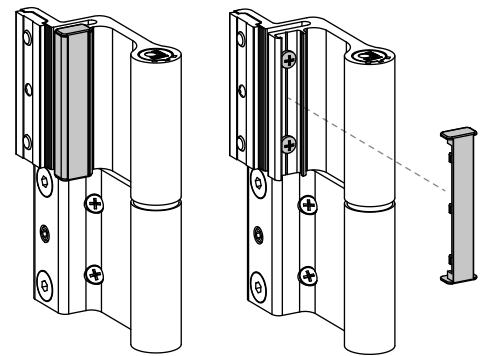
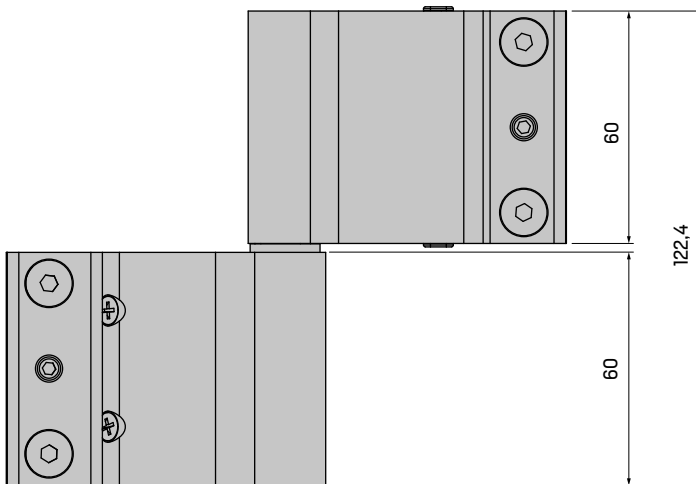

14, 18 CANAL EUROPEO » EJE 10  
EURO GROOVE » 10 SHAFT

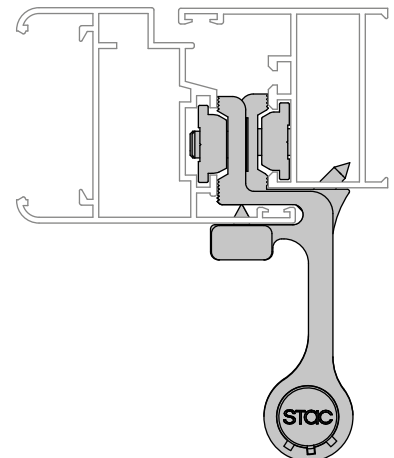

## BISAGRAS CARINA DE 3ª / 4ª HOJA Canal Centrado

3<sup>rd</sup> / 4<sup>th</sup> SASH CARINA HINGES Central Groove

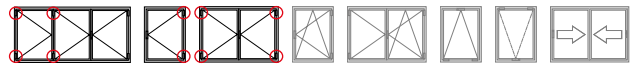

### CARINA DE 3ª HOJA Canal Centrado

3<sup>rd</sup> SASH CARINA Central Groove

A0107	D	**
	I	

40



AL INX

POM



PH2

Bisagras automontables de 3ª y 4ª hoja para perfiles de ventana con Canal Centrado.

- Las contraplacas incorporan un denta-do especial que evitan el deslizamiento.
- El casquillo recubre el bulón de manera que queda aislado de la intemperie.
- Disponibles bisagras reversibles de dos y tres cuerpos.
- Las bisagras se suministran semimon-tadas para su instalación a derechas o a izquierdas.
- Carga máxima con 2 bisagras: **50 kg.**
- Carga máxima con 3 bisagras: **60 kg.**
- Para carga máxima de la bisagra de 4ª hoja consulte la ficha técnica.

Self-assembly 3<sup>rd</sup> and 4<sup>th</sup> sash hinges for windows with Central Groove profiles.

- The counterplates have special serrations to prevent slipping.
- The bushing covers the bolt so that it is insulated from the weather.
- Two- and three-body reversible hinges available.
- The hinges are supplied semi-assembled for right-hand or left-hand installation.
- Maximum load with 2 hinges: **50 kg.**
- Maximum load with 3 hinges: **60 kg.**
- For maximum load of the 4<sup>th</sup> sash hinge refer to the technical data sheet.

### CARINA DE 4ª HOJA Canal Centrado

4<sup>th</sup> SASH CARINA Central Groove

A0108	D	**
	I	

10



AL INX

PA



allen2,5

PH2

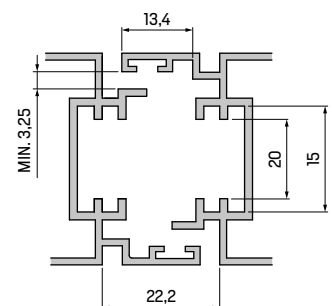
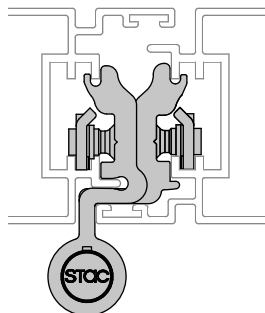
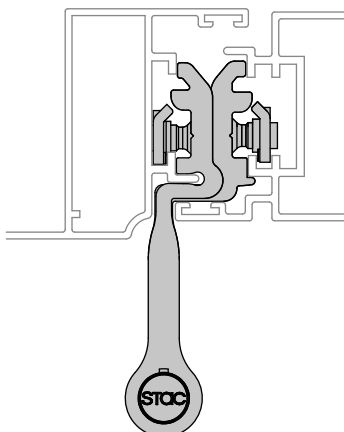
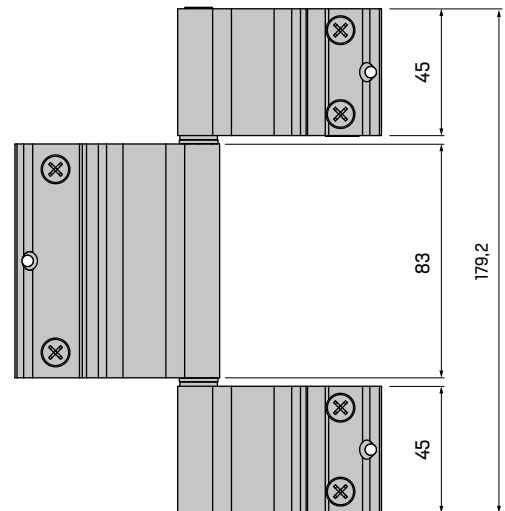
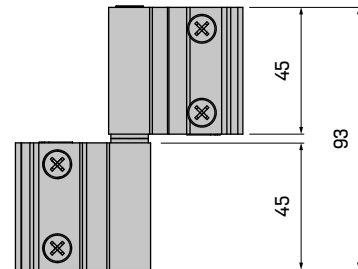

CANAL CENTRADO  
CENTRAL GROOVE



## BISAGRAS CARINA TAMIZ DE 3ª / 4ª HOJA Canal Centrado

3<sup>rd</sup> / 4<sup>th</sup> SASH CARINA TAMIZ HINGES Central Groove

Self-assembly 3<sup>rd</sup> and 4<sup>th</sup> sash hinges for windows with Central Groove profiles.

- The counterplates have special serrations to prevent slipping.
- The hinges incorporate a third hole for a self-tapping screw to secure the hinge to the profile.
- The hinges are supplied mounted on both the right and left-hand side.
- For maximum hinge loads, please refer to the technical data sheet.

Bisagras de ventana automontables de 3ª y 4ª hoja para perfiles con Canal Centrado.

- Las contraplacas incorporan un denticado especial que evitan el deslizamiento.
- Las bisagras incorporan un tercer taladro para un tornillo roscachapa que permite asegurar la fijación al perfil.
- Las bisagras se suministran montadas tanto a derechas como a izquierdas.
- Para cargas máximas de las bisagras consulte la ficha técnica.

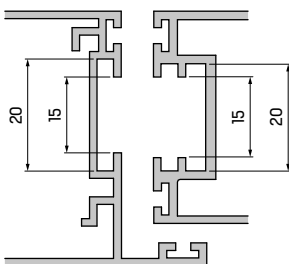
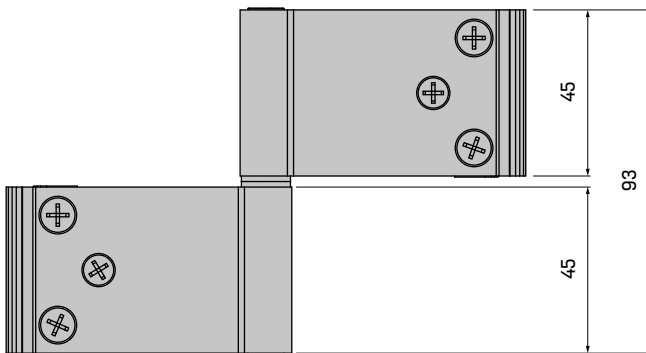
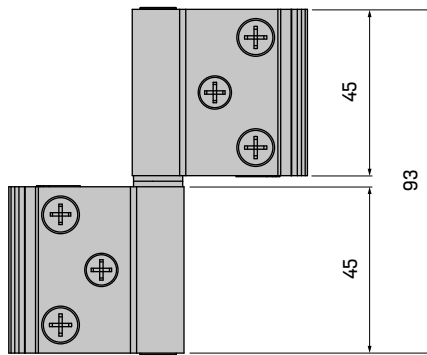

CANAL CENTRADO  
CENTRAL GROOVE

### CARINA TAMIZ DE 3ª HOJA Canal Centrado

3<sup>rd</sup> SASH CARINA TAMIZ Central Groove



A0133	D	**
	I	



### CARINA TAMIZ DE 4ª HOJA Canal Centrado

4<sup>th</sup> SASH CARINA TAMIZ Central Groove



A0134	D	**
	I	

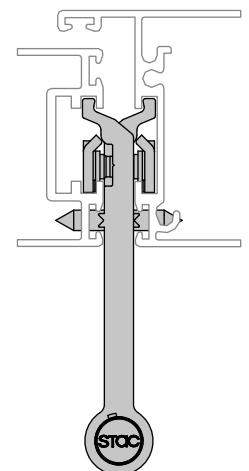
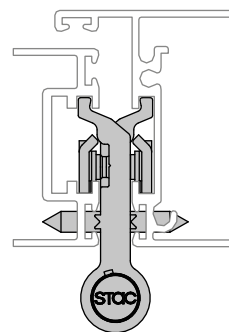

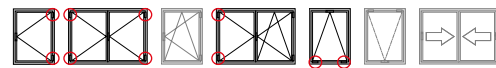

**NORMA FAST 2-PALAS**  
2-LEAF NORMA FAST

025	D	**
	I	



\*\*

RAL

ANODIC

AL INX

PA

CE

allen2,5

PH2

**NORMA FAST 3-PALAS**  
3-LEAF NORMA FAST

P025	D	**



\*\*

RAL

AL INX

PA

CE

allen2,5

PH2

Bisagras de ventana automontables regulables para perfiles con Canal Europeo.

- La pala marco es universal para ajustarse a la mayoría de los perfiles de marco con Canal Europeo.
- Disponen de bulón excéntrico que permite regulación horizontal y de apriete.
- Contraplaca de antideslizamiento que permite duplicar la capacidad de agarre y mejora el premontaje de las bisagras.
- Las bisagras son de dos cuerpos reversibles y se suministran ensambladas tanto a derechas como a izquierdas.

**NORMA FAST 2 PALAS**

- Carga máxima con 2 bisagras: **60 kg.**
- Carga máxima con 3 bisagras: **75 kg.**

**NORMA FAST 3 PALAS**

- Carga máxima con 2 bisagras: **75 kg.**
- Carga máxima con 3 bisagras: **90 kg.**

Self-assembly adjustable window hinges for Euro Groove profiles.

- The hinge frame leaf is universal to fit most of the frame window profiles with Euro Groove.
- They have an eccentric pin for horizontal and tightening adjustment.
- Anti-slip counterplate that doubles the gripping capacity and improves the pre-assembly of the hinges.
- The hinges have two reversible bodies and are supplied assembled both right and left-handed.

**2-LEAF NORMA FAST**

- Maximum load with 2 hinges: **60 kg.**
- Maximum load with 3 hinges: **75 kg.**

**3-LEAF NORMA FAST**

- Maximum load with 2 hinges: **75 kg.**
- Maximum load with 3 hinges: **90 kg.**

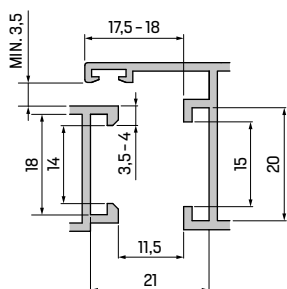
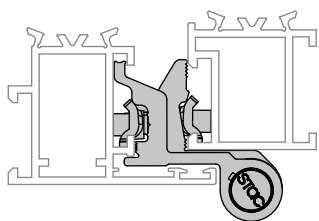
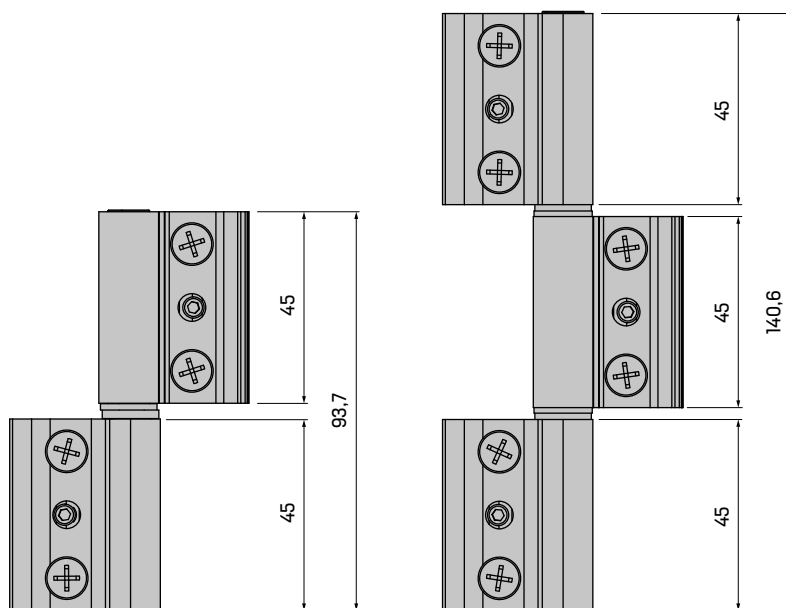

**14, 18 CANAL EUROPEO** » EJE 10  
EURO GROOVE » 10 SHAFT

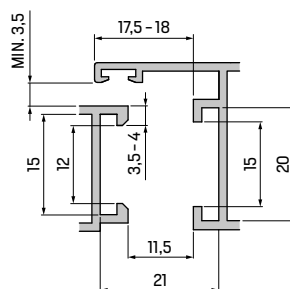

**12, 15 CANAL EUROPEO** » EJE 10  
EURO GROOVE » 10 SHAFT

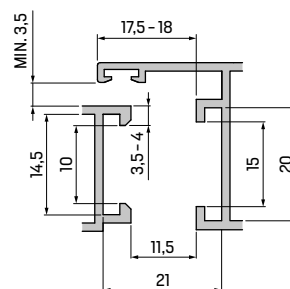

**10, 14.5 CANAL EUROPEO** » EJE 10  
EURO GROOVE » 10 SHAFT



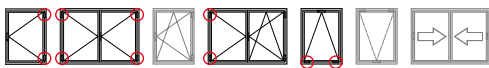

Self-assembly adjustable window hinges with zamak counterplates for Euro Groove profiles.

Bisagras de ventana automontables regulables con contraplacas de zamak para perfiles con Canal Europeo.

**NORMA ECO**  
NORMA ECO

- The hinge frame leaf is universal to fit most of the frame window profiles with Euro Groove.
- They have an eccentric pin for horizontal and tightening adjustment.
- The hinges are supplied with zamak counterplates and are assembled both right and left-handed.
- Maximum load with 2 hinges: 60 kg.
- Maximum load with 3 hinges: 75 kg.

- La pala marco es universal para ajustarse a la mayoría de los perfiles de marco con Canal Europeo.
- Disponen de bulón excéntrico que permite regulación horizontal y de apriete.
- Las bisagras se suministran con contraplacas de zamak y ensambladas tanto a derechas como a izquierdas.
- Carga máxima con 2 bisagras: 60 kg.
- Carga máxima con 3 bisagras: 75 kg.

\*\*

RAL

AL ZM

PA INX

CE

allen2,5

PH2

024	D	**
	I	



**REGULACIONES ADJUSTMENTS » Allen 3**

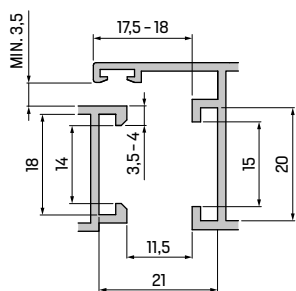
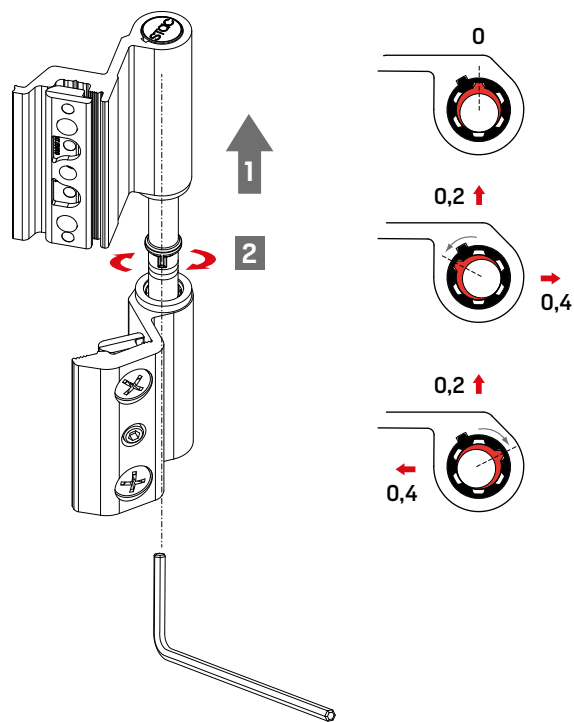
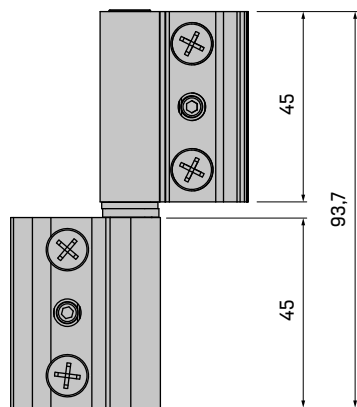

**14, 18 CANAL EUROPEO » EJE 10**  
EURO GROOVE » 10 SHAFT

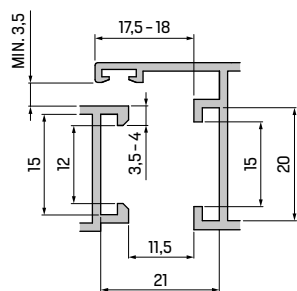

**12, 15 CANAL EUROPEO » EJE 10**  
EURO GROOVE » 10 SHAFT

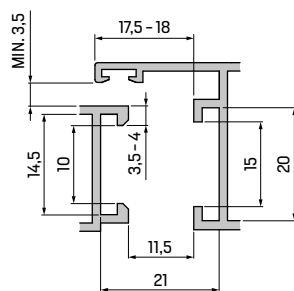

**10, 14.5 CANAL EUROPEO » EJE 10**  
EURO GROOVE » 10 SHAFT

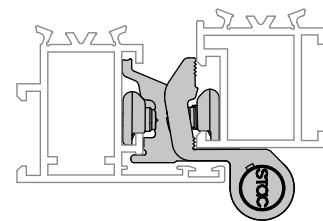

# BISAGRAS 40 / 20

40 / 20 HINGES

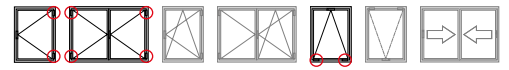

## 40 / 20 2 PALAS

2-LEAF 40 / 20

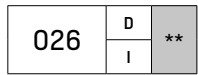

\*\*



AL ZM

PA INX



allen2,5



Bisagras válidas para perfiles con series convencionales tipo 4000 y 6000.

- Las contraplacas de zamak son auto-montables con fijación al perfil a través de tornillos prisioneros.
- Regulación lateral de  $\pm 0,5$  mm a través de casquillo excéntrico.
- Están disponibles bisagras de dos y tres cuerpos y se suministran ensambladas tanto a derechas como a izquierdas.
- Carga máxima con 2 bisagras: **60 kg.**
- Carga máxima con 3 bisagras: **75 kg.**

Hinges suitable for profiles with conventional 4000 and 6000 series.

- Self-assembly counterplates made of zamak and can be fixed to the profile by means of set screws.
- Lateral adjustment  $\pm 0.5$  mm via eccentric bushing.
- Two- and three-part hinges are available and are supplied assembled both right and left-handed.
- Maximum load with 2 hinges: **60 kg.**
- Maximum load with 3 hinges: **75 kg.**

## 40 / 20 3 PALAS

3-LEAF 40 / 20

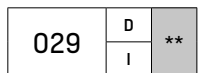

\*\*



AL ZM

PA INX



allen2,5

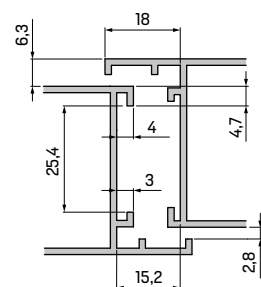
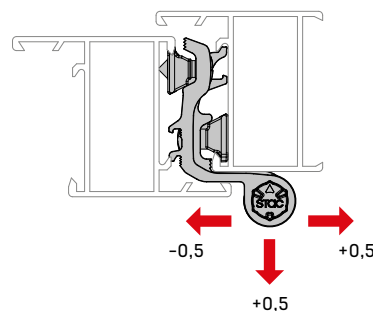
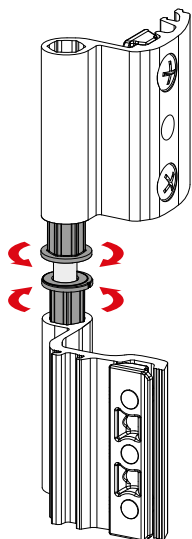
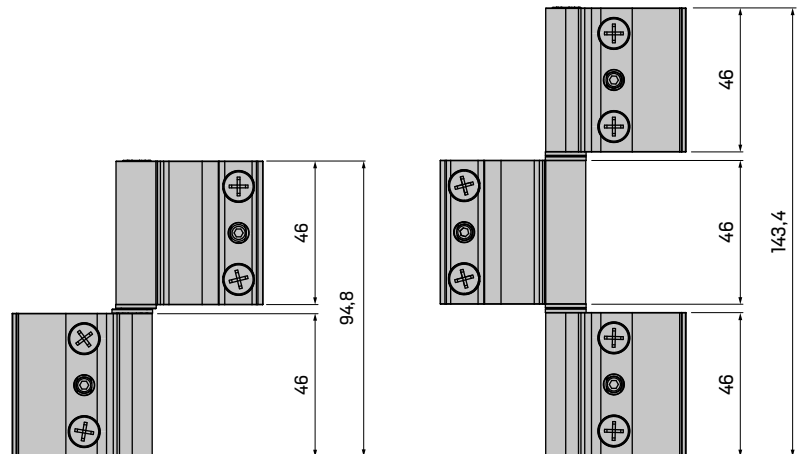

6000 SERIE CONVENCIONAL  
CONVENTIONAL SERIE

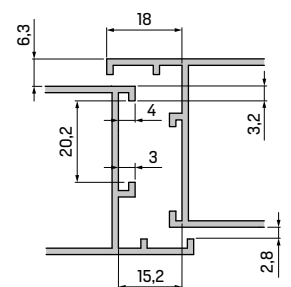

4000 SERIE CONVENCIONAL  
CONVENTIONAL SERIE

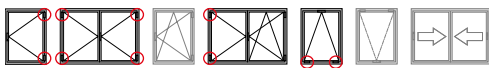

Self-assembly window hinges for Euro Groove profiles.

Bisagras de ventana automontables para perfiles con Canal Europeo.

**HÉRCULES**  
HERCULES

- The counterplates have special serrations to prevent slipping.
- The hinges do not keep opening hand, they are ambidextrous.
- The installation is recommended when there are transversal stresses:  
sashes with width > 1200 mm  
height / width ratio < 2
- They are supplied fully assembled.
- On-site assembly is made easier by the set screw which allows the bolt to be removed.
- The maximum recommended load for 2 or more hinges is 90 kg.

- Las contraplacas incorporan un denticado especial que evitan el deslizamiento.
- Las bisagras no guardan mano de apertura, son ambidiestras.
- Se recomienda su instalación cuando existen esfuerzos transversales:  
hojas con ancho > 1200 mm  
relación alto / ancho < 2
- Se suministran totalmente montadas.
- El montaje en obra es más sencillo gracias al tornillo prisionero que permite la retirada del bulón.
- La carga máxima para 2 o más bisagras es de 90 kg.



C0170 \*\*

40

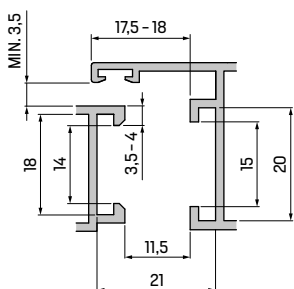
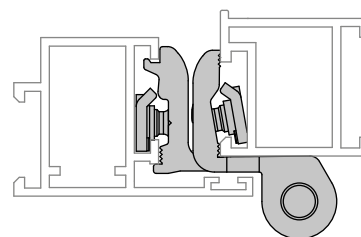
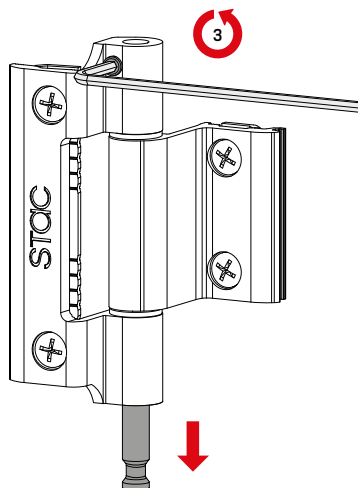
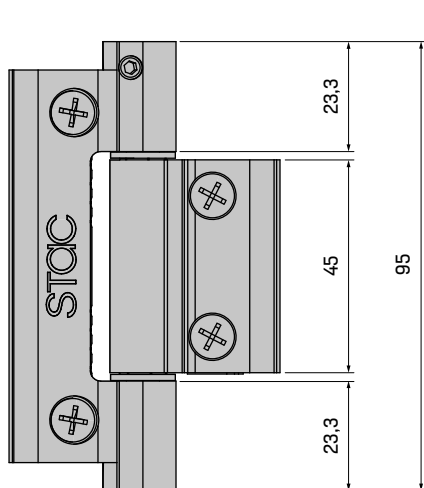

**14, 18 CANAL EUROPEO** » EJE 10  
EURO GROOVE » 10 SHAFT

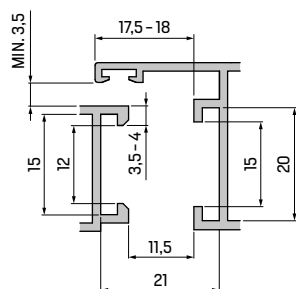

**12, 15 CANAL EUROPEO** » EJE 10  
EURO GROOVE » 10 SHAFT

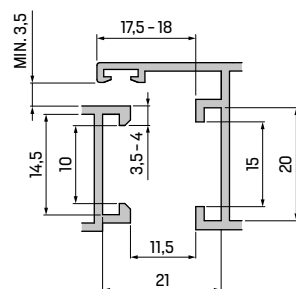

**10, 14.5 CANAL EUROPEO** » EJE 10  
EURO GROOVE » 10 SHAFT



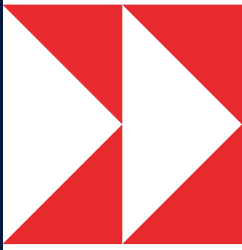

# 02

## MANILLAS Y CREMONAS HANDLES AND CREMONES

- 54 **Línea MINIMALISTA**  
MINIMALIST range
- 58 **Línea SIRIUS**  
SIRIUS range
- 70 **Línea POLARIS**  
POLARIS range
- 74 **Línea ALTAIR**  
ALTAIR range
- 76 **Línea LEO**  
LEO range
- 80 **Línea LYRA**  
LYRA range
- 86 **Línea ATRIA**  
ATRIA range
- 90 **Línea KAIROX**  
KAIROX range
- 94 **Línea HYDRA**  
HYDRA range
- 95 **Kits de fijación**  
Fixing kits
- 100 **Notas técnicas**  
Technical notes



# MANILLAS MINIMALISTAS

MINIMALIST HANDLES

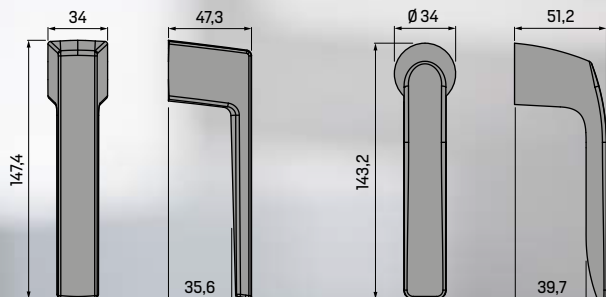

**Mecanismo oculto**  
Concealed mechanism



**Máxima durabilidad**  
Highest durability



**Gama completa de acabados**  
Full range of finishes



**Robustez contrastada**  
Tested robustness

Para las personas que anhelan la sensación de creatividad, calidad y estilo en sus espacios, STAC introduce la línea minimalista de manillas para ventana y puerta con el fin de ofrecer una gama completa de soluciones técnicas de la más alta calidad.

En el planteamiento se ha prescindido de todos los elementos innecesarios, desarrollando un mecanismo oculto que sólo deja expuesta la manilla dando como resultado una familia de manillas que garantizan una gran fiabilidad y robustez a lo largo de todo su vida útil.

## » Línea completa

La línea de manillas minimalistas es válida para diferentes tipos de apertura existentes en el mercado.

- Puerta
- Ventana
- Multipunto
- Aluminio de canal 16 mm

## » Gama completa de acabados

Cada vez son más los proyectos que buscan su singularidad a través de colores o acabados y en donde los accesorios se lacan en los mismos colores que los sistemas de carpintería. La línea minimalista está disponible tanto en lacado blanco o negro como en los colores que conforman la carta RAL, un sistema de combinación de tonalidades que define colores para pinturas, plásticos y recubrimientos.

For those people who wish to have a sensation of creativity, quality and style, STAC is pleased to present their minimalist range of handles for windows and doors, a complete range of the highest quality technical solutions.

The design of these handles does away with all unnecessary elements and we have developed a hidden mechanism so the only part on display is the handle itself. The result is a family of handles with guaranteed reliability and strength throughout their lifecycle.

## » Complete range

The line of minimalist handles is suitable for different types of openings available on the market.

- Door
- Window
- Multipoint systems
- Aluminium systems with 16 mm groove

## » Full range of finishes

There are ever more projects which try to stand out through their used of colour and finishes; the hardware can be painted in the same colour as the aluminium carpentry. The minimalist range is available in both black and white lacquer and the colours that make up the RAL chart, a colour matching system that defines colours for paints, plastics and coatings.



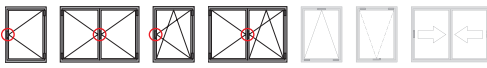

Minimalist window handles with side-hung and tilt & turn opening.

- Minimalist handles with concealed mechanism without cover.
- The handles are supplied with a stronger 8 mm spindle.
- The guide system minimises the clearances on the handles.
- K7701 / K7703 kits incorporating minimalist handle + gearbox are supplied in individual boxes.

**Gearbox**

- Minimalist handles can only be installed with the A770001 gearbox.
- It is supplied with a polyamide supplement that limits the turning of the handle to 90° for side-hung windows.
- It includes an adjustable telescopic piece to adapt to any sash.

Manillas minimalistas para ventanas con apertura practicable y oscilobatiente.

- Manillas minimalistas con mecanismo oculto sin escudo embellecedor.
- Las manillas se suministran con cuadrado de 8 mm más resistente.
- El sistema de guiado permite minimizar las holguras en las manillas.
- Los kits K7701 / K7703 de manilla minimalista + caja de transmisión se suministran en cajas individuales.

**Caja de transmisión**

- Las manillas minimalistas solo montan con la caja de transmisión A770001.
- Se suministra con suplemento de poliamida que limita el giro de la manilla a 90° para aperturas practicables.
- Incluye una pieza telescópica regulable para adaptarse a cualquier hoja.

**MANILLA MINIMALISTA DELTA**  
DELTA MINIMALIST HANDLE

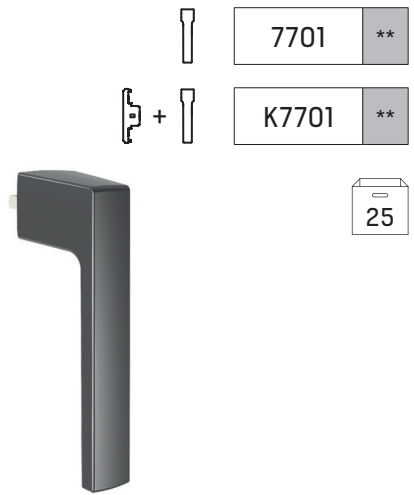

**	7701	**
AL AC	K7701	**

**MANILLA MINIMALISTA GAMMA**  
GAMMA MINIMALIST HANDLE

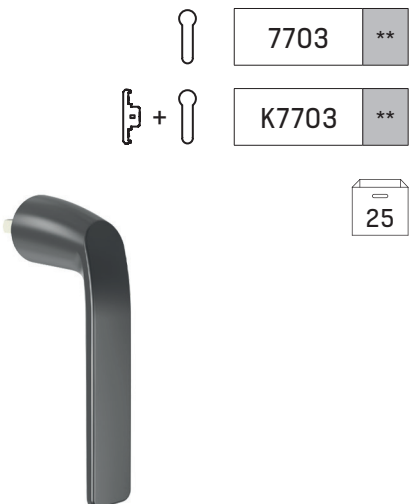

**	7703	**
AL AC	K7703	**

**CAJA DE TRANSMISIÓN MINIMALISTA**  
MINIMALIST GEARBOX



A770001
---------

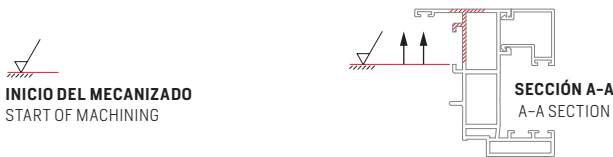
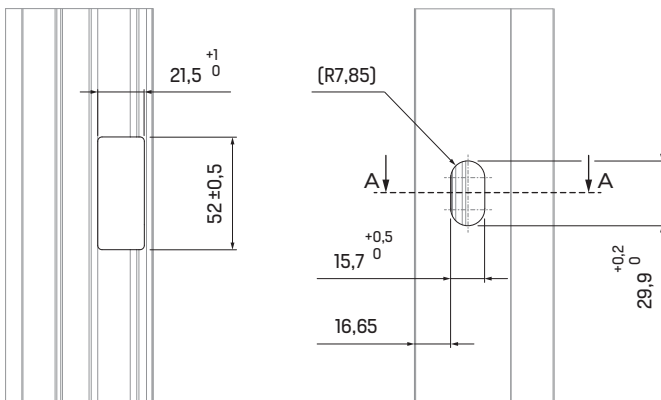
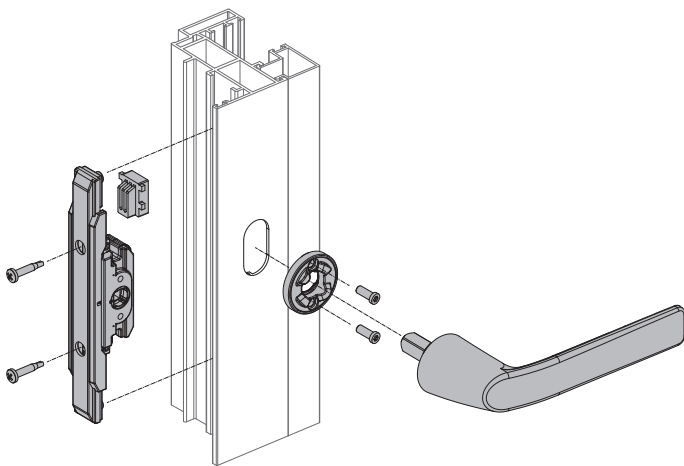

**INICIO DEL MECANIZADO**  
START OF MACHINING

## MINIMALISTAS PARA CAJA DE TRANSMISSION 7 mm

MINIMALIST HANDLES FOR 7 mm GEARBOX

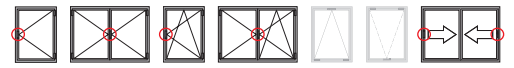

### MANILLA MINIMALISTA DELTA CON 2 APOYOS

GAMMA MINIMALIST HANDLE WITH 2 SUPPORTS

7711 \*\*

25



Manillas minimalistas para ventanas con cierre multipunto, canal 16 mm y soluciones estándar con cuadradillo de 7 mm.

- Manillas minimalistas con mecanismo oculto sin escudo embellecedor.
- En ventanas con cierres multipunto es posible configurar una posición de microventilación.
- Las manillas se suministran con piezas flotantes que permiten la adaptación a diferentes tipos de perfil.
- El sistema de guiado permite minimizar las holguras en las manillas.

Minimalist handles for multipoint windows, 16 mm groove and standard solutions with 7 mm spindle.

- Minimalist handles with concealed mechanism without cover.
- For windows with multipoint locks, it is possible to set a micro-ventilation position.
- The handles are supplied with floating pieces that allow adaptation to different types of profiles.
- The guide system minimises the clearances on the handles.

### MANILLA MINIMALISTA DELTA CON 4 APOYOS

GAMMA MINIMALIST HANDLE WITH 4 SUPPORTS

7721 \*\*

25

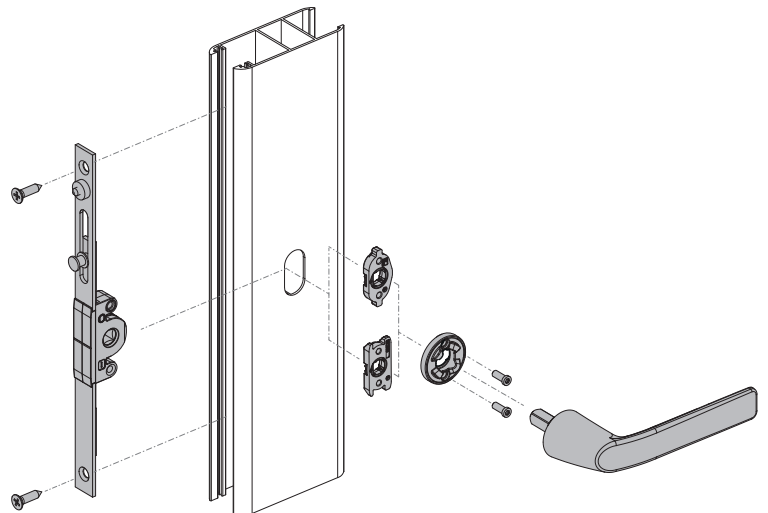
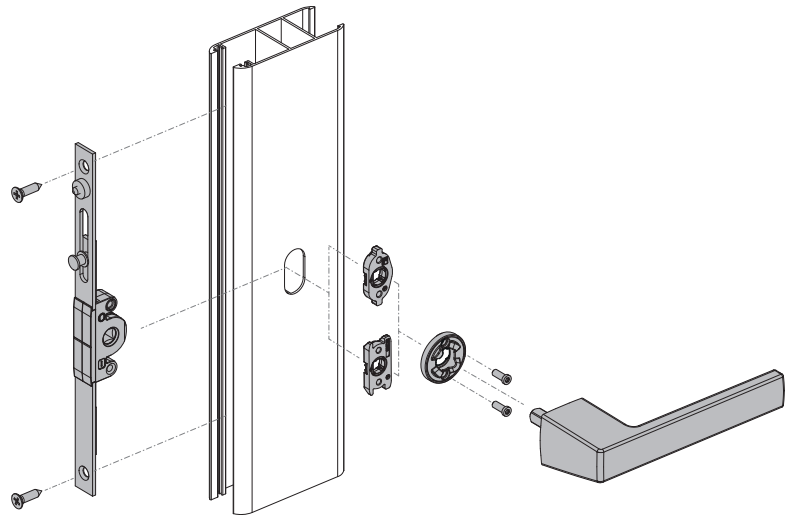

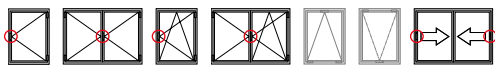

## MINIMALISTAS PARA CAJA DE TRANSMISIÓN 7 mm

### MINIMALIST HANDLES FOR 7 mm GEARBOX

Minimalist handles for multipoint windows, 16 mm groove and standard solutions with 7 mm spindle.

- Minimalist handles with concealed mechanism without cover.
- For windows with multipoint locks, it is possible to set a micro-ventilation position.
- The handles are supplied with floating pieces that allow adaptation to different types of profiles.
- The guide system minimises the clearances on the handles.

Manillas minimalistas para ventanas con cierre multipunto, canal 16 mm y soluciones estándar con cuadrado de 7 mm.

- Manillas minimalistas con mecanismo oculto sin escudo embellecedor.
- En ventanas con cierres multipunto es posible configurar una posición de microventilación.
- Las manillas se suministran con piezas flotantes que permiten la adaptación a diferentes tipos de perfil.
- El sistema de guiado permite minimizar las holguras en las manillas.

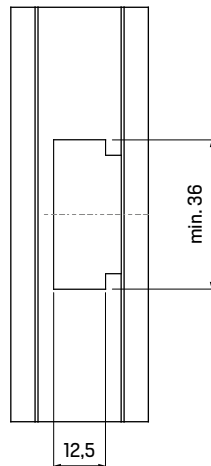
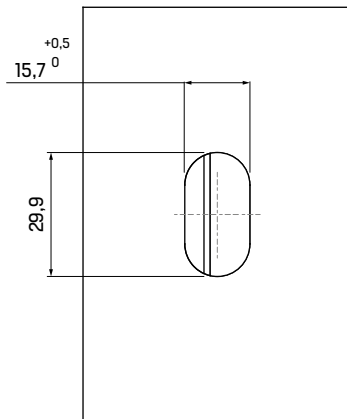

#### ■ 2 APOYOS SUPPORTS

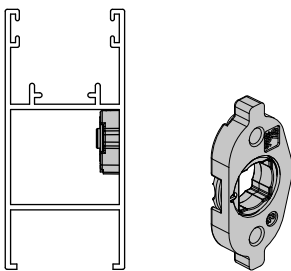

#### ■ 4 APOYOS SUPPORTS

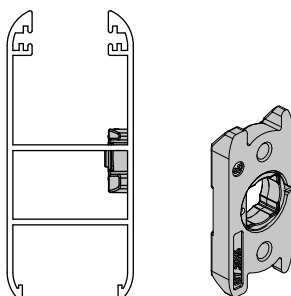

### MANILLA MINIMALISTA GAMMA CON 2 APOYOS

#### GAMMA MINIMALIST HANDLE WITH 2 SUPPORTS



7713 \*\*

25

### MANILLA MINIMALISTA GAMMA CON 4 APOYOS

#### GAMMA MINIMALIST HANDLE WITH 4 SUPPORTS



7723 \*\*

25

# MANETA EXTRAÍBLE

DETACHABLE HANDLE



**Clipaje directo**  
Direct clipping



**Indicación sonora**  
Sound indication



**Gama completa de acabados**  
Full range of finishes



**Robustez contrastada**  
Tested robustness

En un mercado en el que la seguridad se ha posicionado como una de las características más demandadas entre los clientes, se ha evolucionado hacia sistemas que incorporan dispositivos de seguridad que limitan el accionamiento de la ventana a través de manetas extraíbles.

STAC ha posicionado la cremona SIRIUS extraíble como referente dentro del mercado de cremonas con maneta extraíble destacando por su estándar de calidad e innovación logrando una alta demanda del producto. Siguiendo esta tendencia, los clientes demandan un mecanismo de reducidas dimensiones para las manillas con cuadradillo, por lo que STAC añade a su gama de herraje con manetas extraíbles la manilla POLARIS extraíble. Este novedoso producto llega para dar una solución sólida y robusta en el exigente mercado del cerramiento.

## » Clipaje directo sobre el escudo

Una pieza de retención impide que la maneta se salga de la acanaladura, pudiendo estar instalada y operativa durante todo el tiempo que deseemos. Para hacer el desbloqueo, es el usuario final el que tiene que ejercer una ligera presión en el clip de retención para liberar la maneta.

## » Durabilidad a ciclos

Cremonas y manillas disponen de una pieza base sobre el escudo en la que se ha cambiado la cavidad para hacer el arrastre por una doble ranura en "T". El mecanismo en T, tiene un diseño que maximiza las caras de contacto entre las piezas de transmisión de maneta y escudo, y al mismo tiempo se aleja el punto de contacto del eje de rotación para disminuir el par de torsión.

In a market where security has become one of the most important demands of the client, the cremones and handles have evolved towards systems which incorporate security mechanisms which restrict opening of the window via detachable handles.

The market leading SIRIUS detachable cremone from STAC stands out for the standards of quality and innovation which make it a highly desirable product in the market for cremones with removable handles. In keeping with this trend, clients have been asking for smaller, sleeper mechanisms for handles with spindles and so STAC has added the POLARIS detachable handle to their hardware range. This new product offers a solid and robust solution for the demanding market of door and window hardware.

## » Direct clipping onto the scutcheon

A retaining component that impedes the handle coming out of the grooves and being able to be installed and operative for as long as is required. To unblock it, the end user simply lightly presses the retention clip.

## » Cycle durability

Cremones and handles have a base component over the scutcheon that is use to pull has been changed to a "T" shape double slot. The T mechanism is designed to maximise the contact faces between the handle transmission components and the backplate and at the same time the contact point with the rotation shaft is avoided in order to reduce the torque.

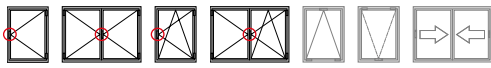

## CREMONAS EXTRAÍBLES SIRIUS

### SIRIUS DETACHABLE CREMONES

Cremones compatible with SIRIUS detachable handle and valid for side-hung, french style and tilt & turn windows.

- The SIRIUS detachable handle is clipped directly onto the scutcheon of the cremones.
- The user can unlock and release the detachable handle by slightly pressing on the locking clip.
- The cremone handles are available in the colours of the RAL chart.

Cremonas compatibles con maneta extraíble para ventanas practicables, a la francesa y oscilobatientes.

- El clipaje de la maneta extraíble SIRIUS se realiza de forma directa sobre el escudo de las cremonas.
- A través de una ligera presión en el clip de retención el usuario puede desbloquear y liberar la maneta extraíble.
- Las cremonas están disponibles en los colores que conforman la carta RAL.

SIRIUS detachable handle on page 61.

Maneta extraíble SIRIUS en página 61.

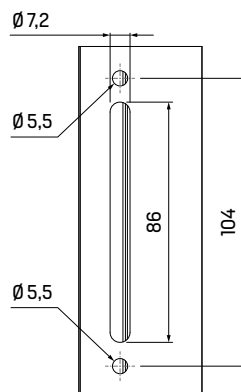
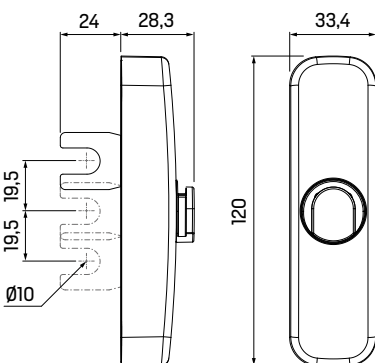
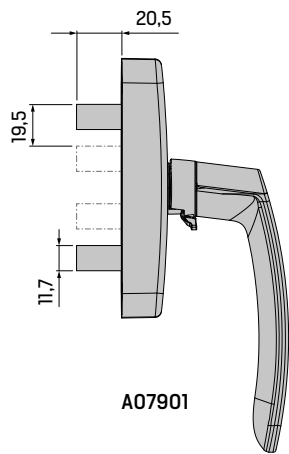
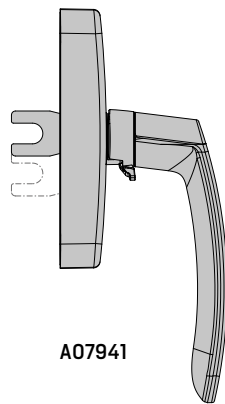
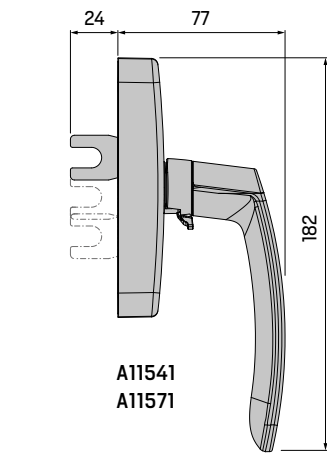

## CREMONAS OSCIOBATIENTES SIRIUS

### SIRIUS TILT & TURN CREMONES



A11541 \*\*



A11571 \*\*

25



## CREMONA PRACTICABLE SIRIUS

### SIRIUS SIDE-HUNG CREMONE



A07941 \*\*

20



## CREMONA A LA FRANCESA SIRIUS

### SIRIUS FRENCH STYLE CREMONE



A07901 \*\*

20



## MANILLAS EXTRAÍBLES POLARIS

POLARIS DETACHABLE HANDLES

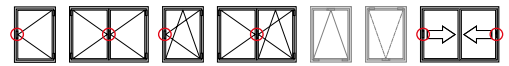

### MANILLA POLARIS

POLARIS HANDLE

S5774 \*\* □ 7 x 27 mm

25



Manillas compatibles con la maneta extraíble para ventanas practicables u oscilobatientes.

- El clipaje de la maneta extraíble SIRIUS se realiza de forma directa sobre el escudo de las manillas.
- A través de una ligera presión en el clip de retención el usuario puede desbloquear y liberar la maneta extraíble.
- La manilla extraíble es válida para ventanas con apertura exterior.
- En ventanas con cierres multipunto es posible configurar una posición de micro-ventilación.

Handles compatible with the detachable handle for side-hung or tilt & turn windows.

- The SIRIUS detachable handle is clipped directly onto the scutcheon of the handles.
- The user can unlock and release the detachable handle by slightly pressing on the locking clip.
- The removable handle is valid for windows with outward opening.
- For windows with multipoint locks, it is possible to set a micro-ventilation position.

### MANILLA DE APERTURA EXTERIOR POLARIS

POLARIS OUTWARD OPENING HANDLE

T5774 \*\* □ 7 x 64 mm

25

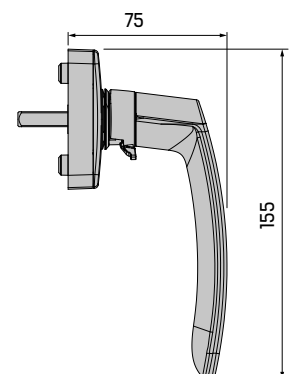
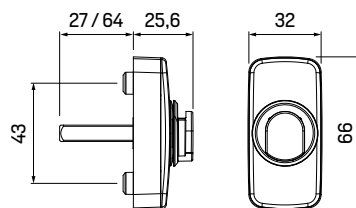
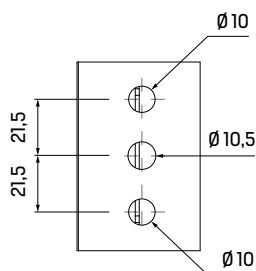

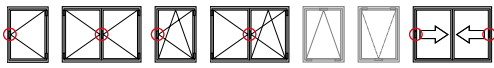

## MANETA EXTRAÍBLE SIRIUS

### SIRIUS DETACHABLE HANDLE

Detachable handle valid for SIRIUS detachable cremones and POLARIS detachable handles.

- The SIRIUS detachable handle is clipped directly onto the scutcheon of the handles.
- The user can unlock and release the detachable handle by slightly pressing on the locking clip.

Maneta extraíble válida para las cremonas extraíbles SIRIUS y manillas extraíbles POLARIS.

- El clipaje de la maneta extraíble SIRIUS se realiza de forma directa sobre el escudo de las manillas.
- A través de una ligera presión en el clip de retención el usuario puede desbloquear y liberar la maneta extraíble.

## MANETA EXTRAÍBLE SIRIUS

### SIRIUS DETACHABLE HANDLE



0507167 \*\*

20

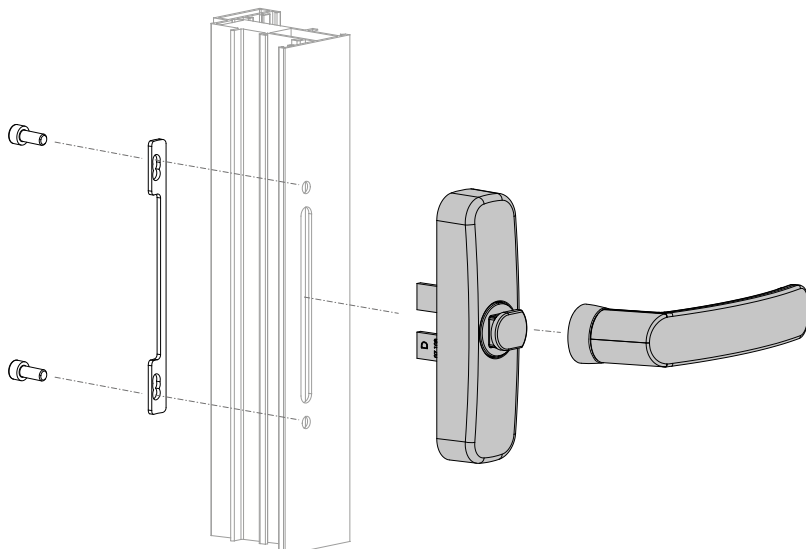
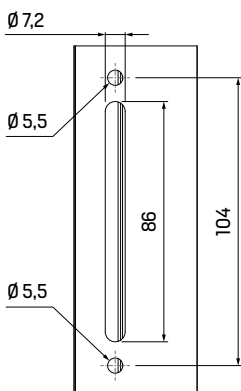
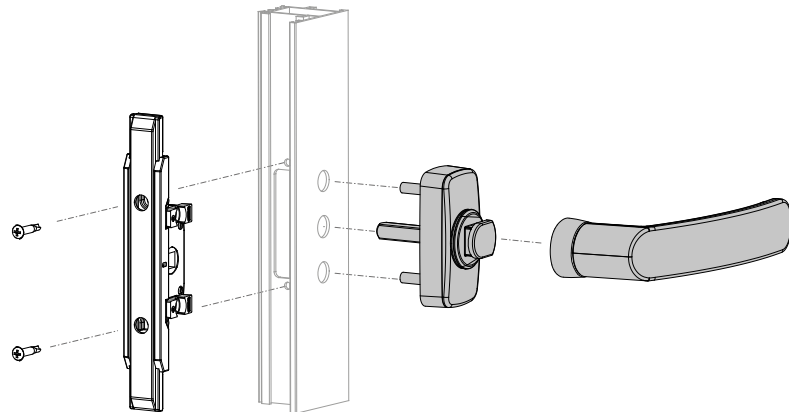
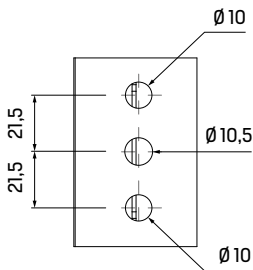



## CREMONAS SIRIUS PARA APERTURA PRACTICABLE

SIDE-HUNG WINDOW SIRIUS CREMONES

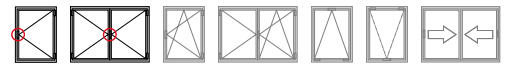

### CREMONAS PRACTICABLES SIRIUS

SIRIUS SIDE-HUNG CREMONES

A0790 \*\*

**Derecha**  
Right

A0791 \*\*

**Izquierda**  
Left

20



Cremonas de ventana practicable.

- Cremonas con diseño de líneas puras y estilizadas compatibles con el sistema de fijación rápida FAST.
- Las palas y los piñones de las cremonas se han fabricado en acero.
- Por cada caja de cremonas de apertura a derechas se suministran cinco kits de palas para aperturas a izquierdas.

#### Cremona SIRIUS SLIM

- La cremona SIRIUS SLIM es la solución ideal para instalaciones en ventanas o puertas balconeras en donde la persiana no habilita el espacio necesario para el montaje de una cremona tradicional.

Cremones for side-hung windows.

- Cremones with a pure and stylized lines design compatible with the FAST quick fastening system.
- The levers and pinions of the cremones are made of steel.
- Five lever kits for left-hand opening are supplied for each box of right-hand opening cremones.

#### SIRIUS SLIM cremona

- The SIRIUS SLIM cremona is envisaged as the ideal solution for installations on windows or balcony doors where the shutters do not leave the space necessary for the mounting of a traditional cremona.

### CREMONA PRACTICABLE SIRIUS SLIM

SIRIUS SLIM SIDE-HUNG CREMONE

A0790S \*\*

10

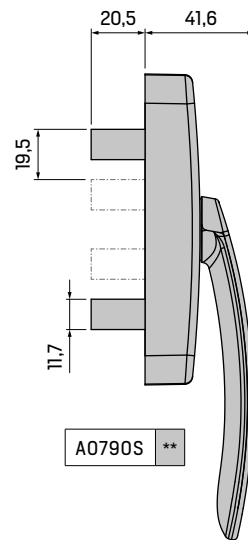

A0790S \*\*

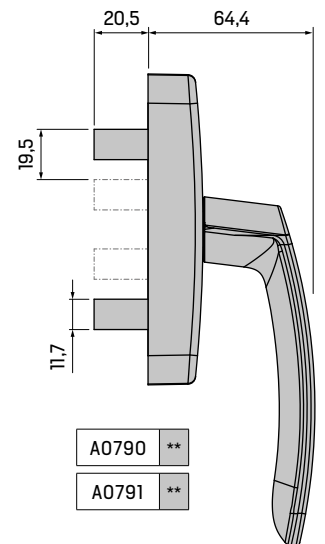

A0790 \*\*

A0791 \*\*

### CREMONAS A LA FRANCESA SIRIUS

SIRIUS FRENCH STYLE CREMONES

A0794 \*\*

**Pala corta**  
Short lever

P0794 \*\*

**Pala larga**  
Long lever

20

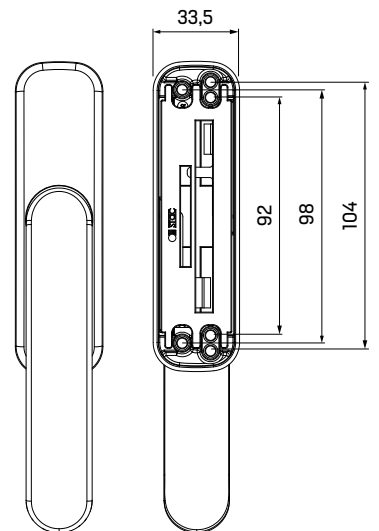
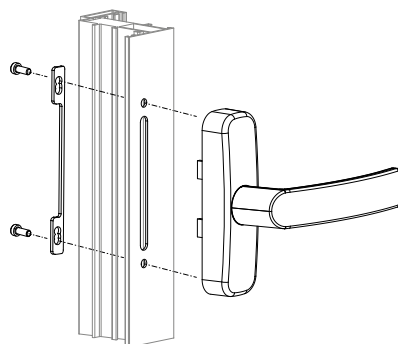

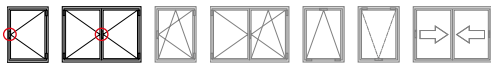

## CREMONA SIRIUS BLOCK PARA APERTURA PRACTICABLE

### SIDE-HUNG WINDOW SIRIUS BLOCK CREMONE

Window cremone with key lock compatible with side-hung openings.

- The lock of the cremone handle is done by means of a key.
- The cremone is compatible with the FAST quick fastening system.
- The levers and the pinion of the cremone are made of steel.

Cremona de ventana con llave compatibles con aperturas practicables.

- El bloqueo de la maneta de la cremone se realiza mediante llave.
- La cremone es compatible con el sistema de fijación rápida FAST.
- Las palas y el piñón de la cremone se han fabricado en acero.

## CREMONA PRACTICABLE SIRIUS BLOCK

### SIRIUS BLOCK SIDE-HUNG CREMONE



A0793 \*\*

20



## KIT DE PALAS PARA APERTURAS A IZQUIERDAS

### LEVER KIT FOR LEFT-HAND OPENINGS

AC

0507110

100

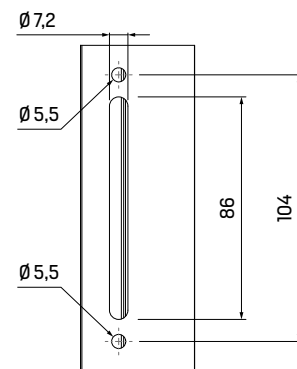
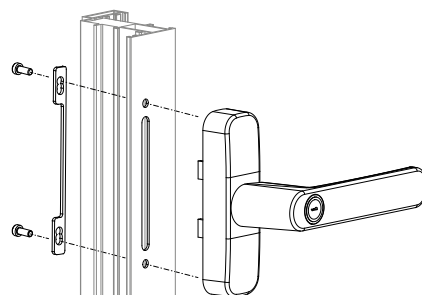
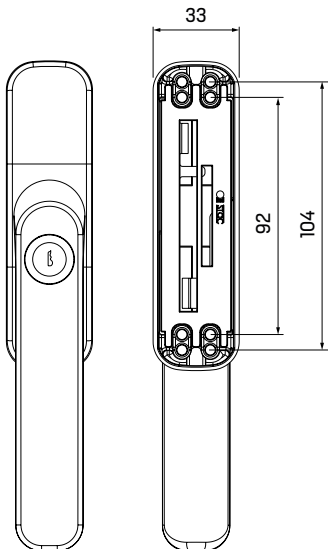
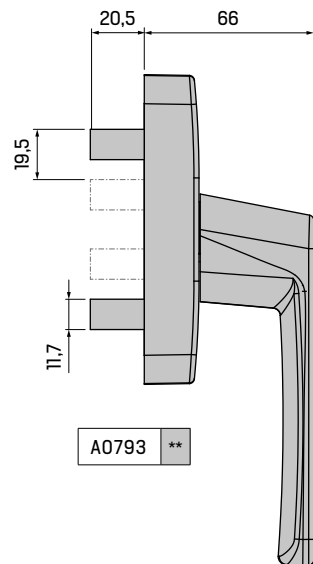
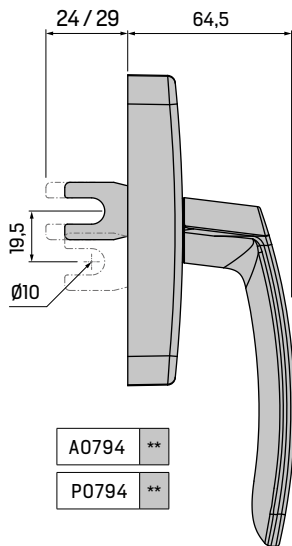

## CREMONAS SIRIUS PARA APERTURA OSCILOBATIENTE

TILT & TURN WINDOW SIRIUS CREMONES

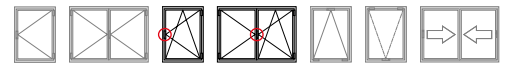

### CREMONAS OSCILOBATIENTES SIRIUS

SIRIUS TILT & TURN CREMONES

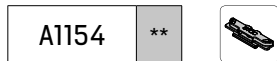

Cremonas de ventana compatibles con aperturas oscilobatientes.

- Cremonas con diseño de líneas puras y estilizadas compatibles con el sistema de fijación rápida FAST.
- Las palas y los piñones de las cremonas se han fabricado en acero.

#### Cremona SIRIUS SLIM

- La cremona SIRIUS SLIM es la solución ideal para instalaciones en puertas en donde la persiana no habilita el espacio necesario para el montaje de una cremona tradicional.

Window cremones compatible with tilt & turn openings.

- Cremones with a pure and stylized lines design compatible with the FAST quick fastening system.

- The levers and pinions of the cremone are made of steel.

#### SIRIUS SLIM cremone

- The SIRIUS SLIM cremone is envisaged as the ideal solution for installations of doors where the shutters do not leave the space necessary for the mounting of a traditional cremone.

### CREMONA OSCILOBATIENTE SIRIUS SLIM

SIRIUS SLIM TILT & TURN CREMONE

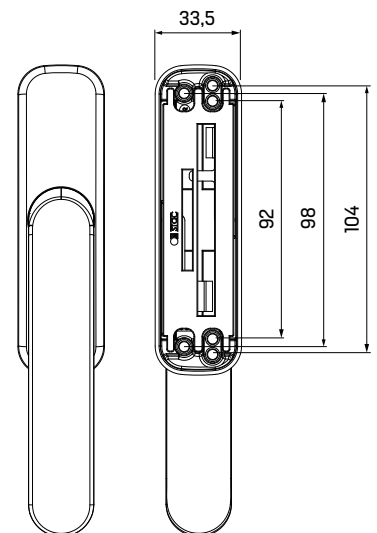
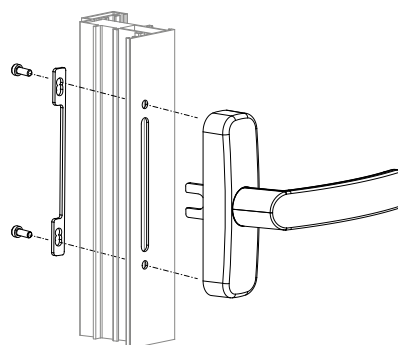
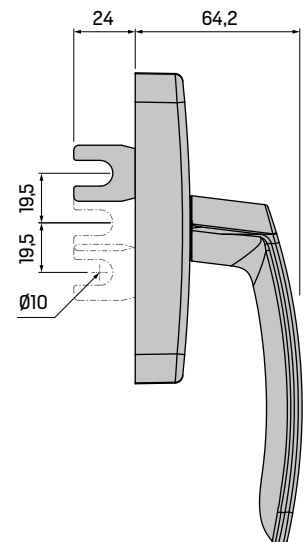
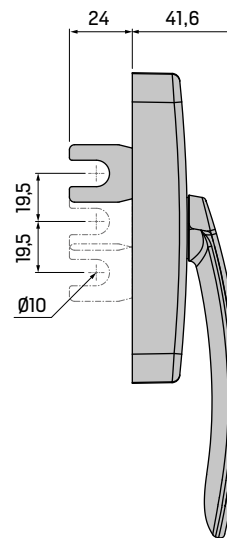

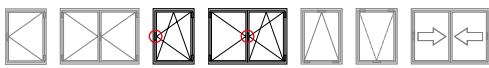

## CREMONAS SIRIUS BLOCK PARA APERTURA OSCILOBATIENTE

TILT & TURN WINDOW SIRIUS BLOCK CREMONES

Window cremones with key lock compatible with tilt & turn openings.

- The lock of the cremone handle is done by means of a key.
- The cylinder mechanism has been specially designed for tilt & turn windows with a tilt-before-turn opening system allowing the cremone to be locked at 90° with one touch and total blocking with a key.
- There are two locking positions for tilt-before-turn windows:

**turning key 90°**, the cremone allows to tilt but not to open the window.

**turning key 180°**, the cremone is blocked, preventing both opening and tilting the window.

Cremonas de ventana con llave compatibles con aperturas oscilobatientes.

- El bloqueo de la maneta de la cremona se realiza mediante llave.
- Mecanismo de bombillo especialmente diseñado para ventanas oscilobatientes con sistema de apertura de manobra lógica permitiendo el bloqueo a 90° de la cremona con una pulsación y el bloqueo total con llave.
- En ventanas con maniobra lógica existen dos posiciones de bloqueo:

**girando la llave 90°**, la cremona permite oscilar pero no abrir la ventana.

**girando la llave 180°**, la cremona se bloquea impidiendo tanto abrir como oscilar la ventana.

## CREMONA OSCILOBATIENTE SIRIUS BLOCK

SIRIUS BLOCK TILT & TURN CREMONE



A1160 \*\*



A1163 \*\*

20

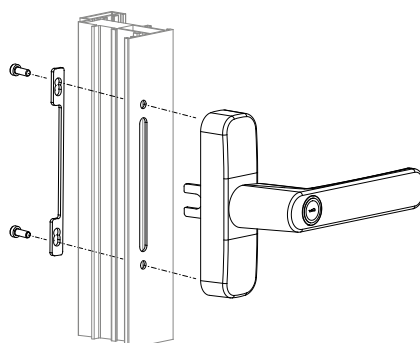
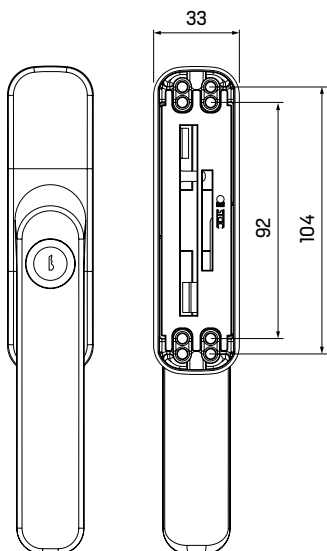
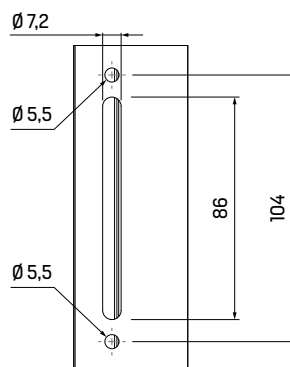
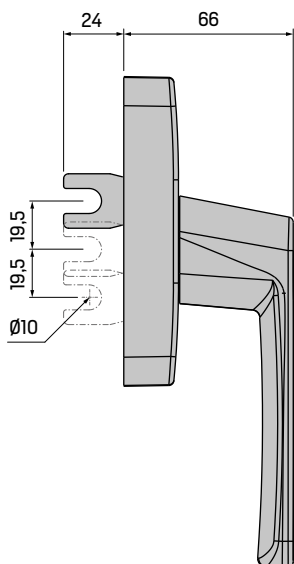

## FUNDA DE TRANSMISIÓN

TRANSMISSION COVER

PA

0511193

200



**Por defecto, las cremonas son suministradas con funda de transmisión, si no se indica lo contrario.**

By default, cremones are supplied with a transmission cover, unless otherwise indicated.

# CREMONAS SIRIUS PARA APERTURA PROYECTANTE

TOP-HUNG WINDOW SIRIUS CREMONES

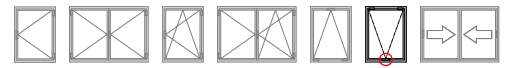

## CREMONA PROYECTANTE SIRIUS

SIRIUS TOP-HUNG CREMONE

1166 \*\*

20



Cremonas para ventanas proyectantes.

- Las palas están desplazadas para permitir la apertura proyectante.
- Disponible versión de cremona de seguridad con cerradura de llave.
- Por defecto, las cremonas para apertura proyectante se suministran sin el kit de transmisión ref. 180100.

Cremones for top-hung windows.

- The levers of the cremones are displaced to allow the top-hung opening.
- Security cremona version with key lock available.
- By default, the cremones for top-hung window are supplied without the transmission kit ref. 180100.

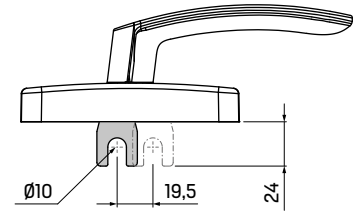
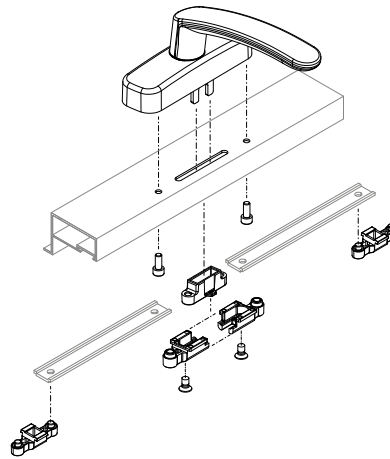

## CREMONAS ACODADAS PROYECTANTES SIRIUS

SIRIUS TOP-HUNG OFFSET CREMONES

1161 \*\* Derecha Right

1162 \*\* Izquierda Left

20

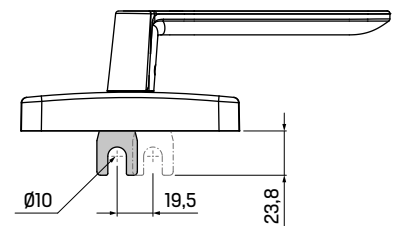
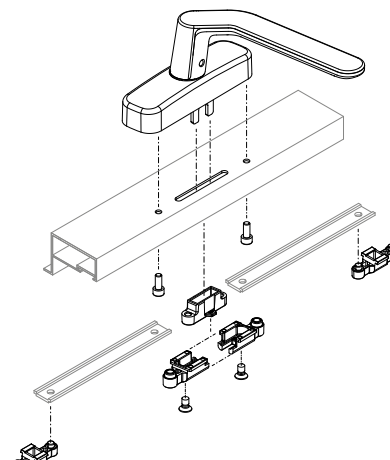

## CREMONAS ACODADAS SIRIUS CON DOBLE PALA

SIRIUS OFFSET CREMONES WITH DOUBLE LEVER

R1161 \*\* Derecha Right

R1162 \*\* Izquierda Left

20

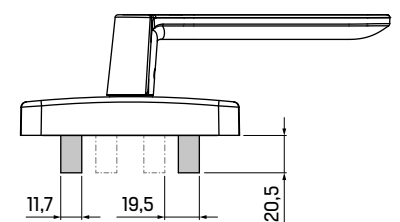
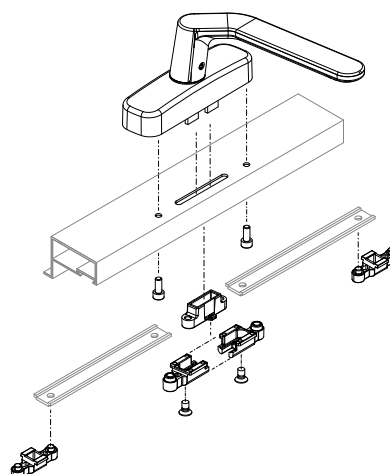

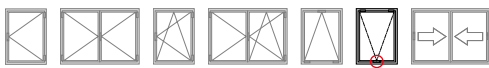

Cremones for top-hung windows.

- The levers of the cremones are displaced to allow the top-hung opening.
- Security cremone version with key lock available.
- By default, the cremones for top-hung window are supplied without the transmission kit ref. 180100.

Cremonas para ventanas proyectantes.

- Las palas están desplazadas para permitir la apertura proyectante.
- Disponible versión de cremona de seguridad con cerradura de llave.
- Por defecto, las cremonas para apertura proyectante se suministran sin el kit de transmisión ref. 180100.

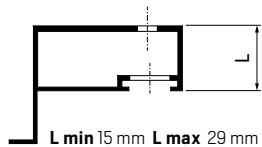

**CREMONA PROYECTANTE**  
TOP-HUNG CREMONE

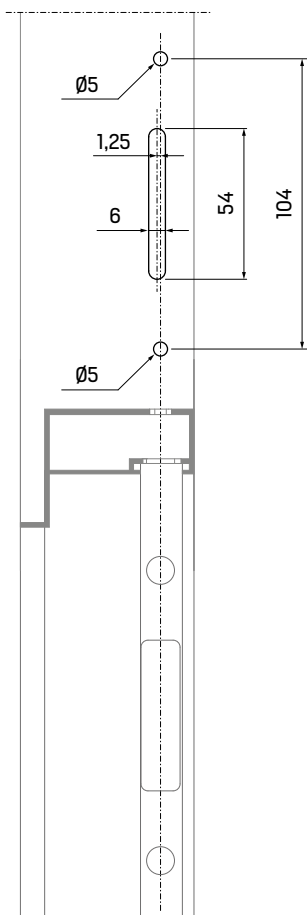

**KIT DE TRANSMISIÓN**  
TRANSMISSION KIT

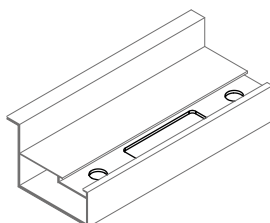
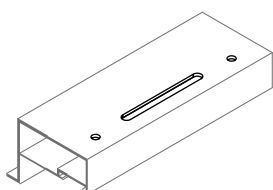
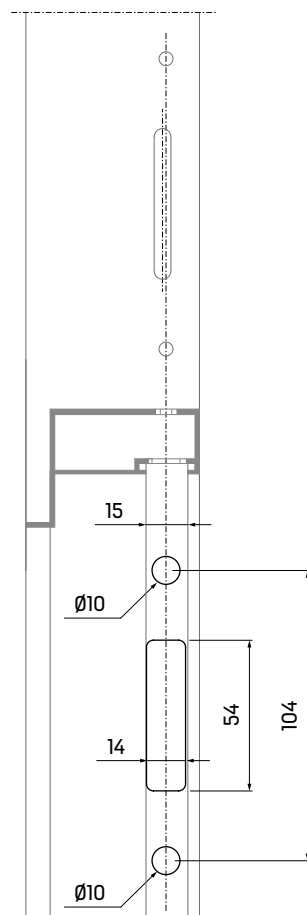

**CREMONA PROYECTANTE SIRIUS BLOCK**  
SIRIUS BLOCK TOP-HUNG CREMONE



A1167 \*\*

20



**KIT DE TRANSMISIÓN PROYECTANTE**  
TOP-HUNG WINDOW TRANSMISSION KIT



180100

50



**Por defecto, las cremonas para apertura proyectante son suministradas sin el kit de transmisión.**

By default, top-hung window cremones are supplied without transmission kit.

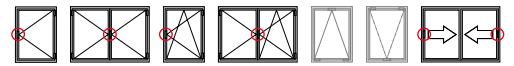

**MANILLAS SIRIUS**  
SIRIUS HANDLES

A0771 \*\* □ 7 x 26 mm

A0775 \*\* □ 7 x 59 mm

25

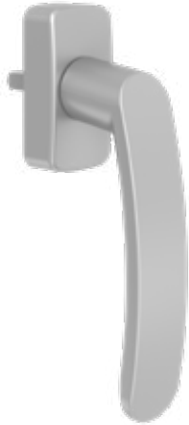

Manillas para ventanas practicables, oscilobatientes o correderas.

- Las manillas son válidas para caja de transmisión y cierre multipunto.
- Las manillas incorporan un mecanismo de transmisión enjaulado para el escudo de la maneta y reforzado con soporte de zamak que lo dota de mayor resistencia.

Kits de fijación compatibles en página 96.

Handles for side-hung, tilt & turn or sliding windows.

- The handles are valid for gearboxes and multipoint locks.
- The handles incorporate a caged transmission for the handle scutcheon and reinforced with a zamak support that makes it more resistant.

Compatible fixing kits on page 96.

» MECANISMO REFORZADO  
REINFORCED MECHANISM

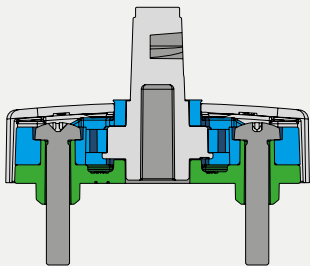

» MECANIZADO DEL PERFIL PROFILE MACHINING

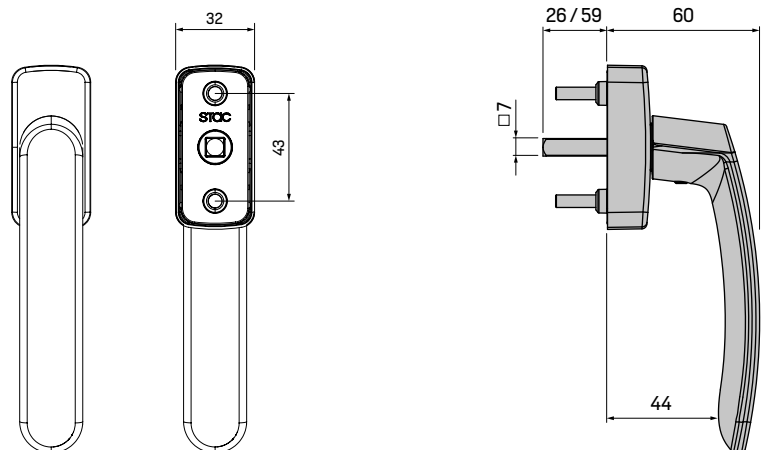
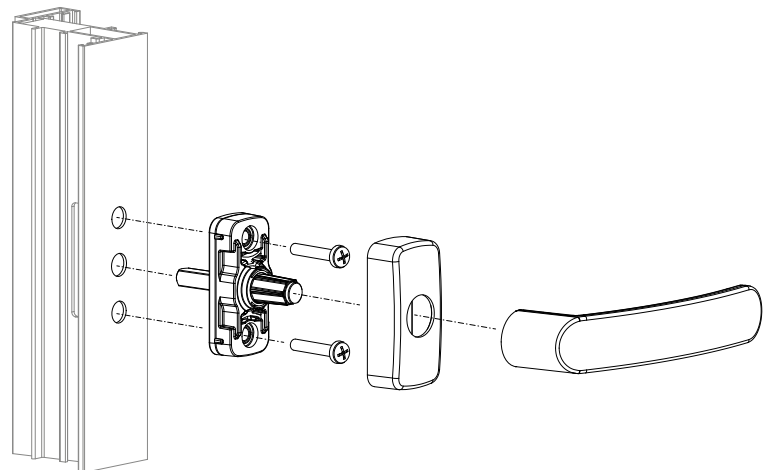
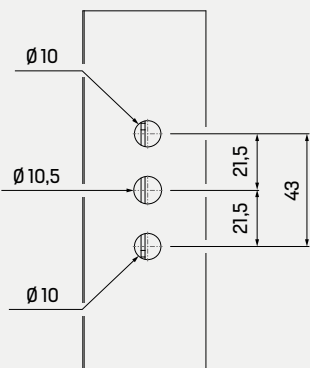



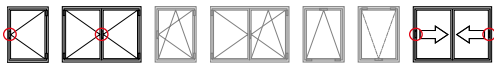

## MANILLAS ACODADAS SIRIUS

### SIRIUS OFFSET HANDLES

Offset handles for sliding windows with single point or multipoint locking systems.

- Aesthetics harmonized with the SIRIUS line of cremone and handles.
- The handles are suitable for inward and outward installations.
- The handles are suitable for the insertion of threaded rivets for fixing to the profile by means of millimetre-threaded screws.

Manillas acodadas para ventanas correderas con sistemas de cierre monopunto o multipunto.

- Estética harmonizada con la línea de cremonas y manillas SIRIUS.
- Las manillas son válidas para montajes interiores y exteriores.
- Las manillas son aptas para la incorporación de remaches roscados para fijación al perfil por medio de tornillos de rosca milimétrica.

### MANILLA ACODADA SIRIUS

#### SIRIUS OFFSET HANDLE



Derecha  
Right

B0777

25



### MANILLA ACODADA SIRIUS

#### SIRIUS OFFSET HANDLE



Izquierda  
Left

B0778

25

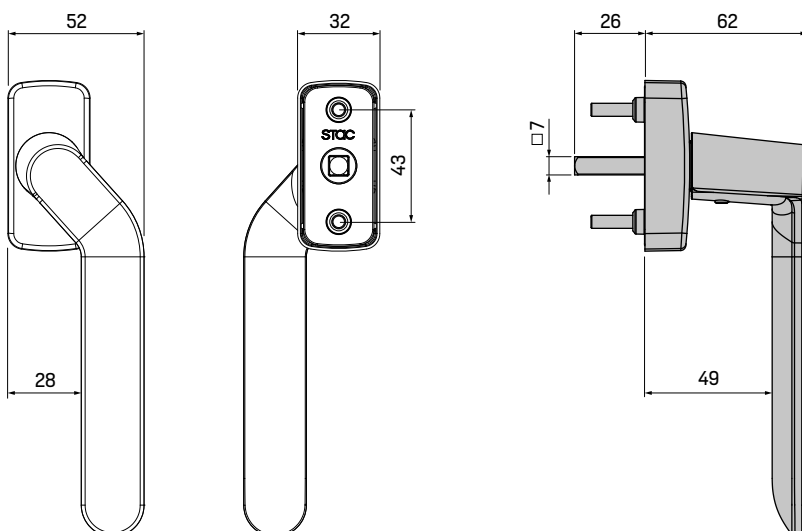
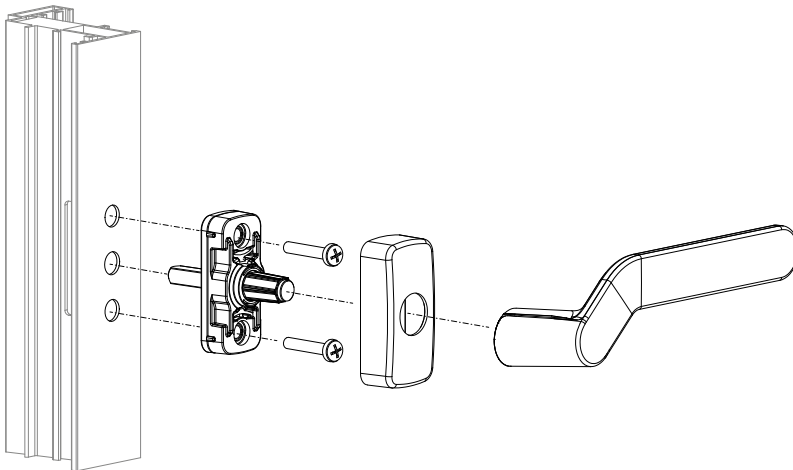

#### » MECANIZADO DEL PERFIL PROFILE MACHINING

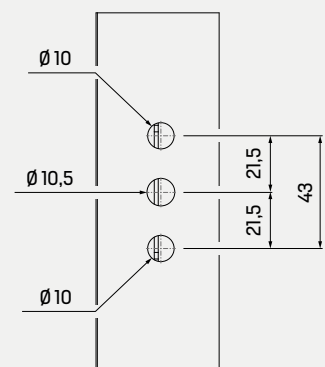

## MANILLAS POLARIS

### POLARIS HANDLES

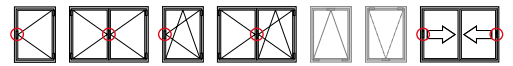

## MANILLA POLARIS

### POLARIS HANDLE

S5771 \*\* □ 7 x 27 mm

25

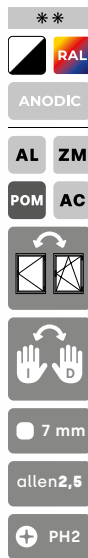

Manillas para ventanas practicables, oscilobatientes o correderas.

- Las manillas son válidas para caja de transmisión y cierre multipunto.
- Las manillas se suministran con escudo giratorio integrado que reduce notablemente los tiempos de instalación.

Kits de fijación compatibles en página 98.

Handles for side-hung, tilt & turn or sliding windows.

- The handles are valid for gearboxes and multipoint locks.
- The handles are supplied with an integrated rotary scutcheon significantly reduces handle installation times.

Compatible fixing kits on page 98.

## MANILLAS DE APERTURA EXTERIOR POLARIS

### POLARIS OUTWARD OPENING HANDLES

S5775 \*\* □ 7 x 64 mm

T5775 \*\* □ 7 x 75 mm

25

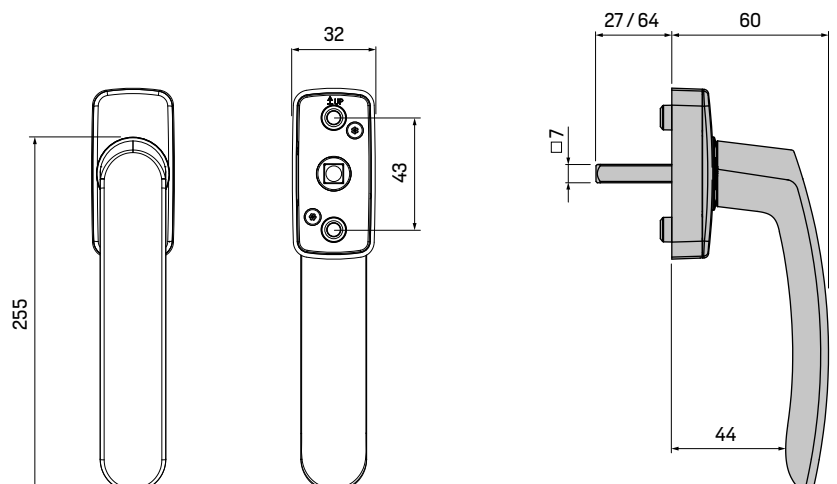
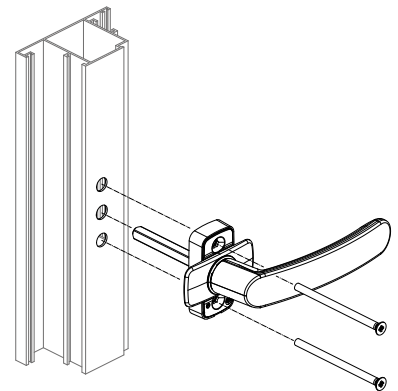
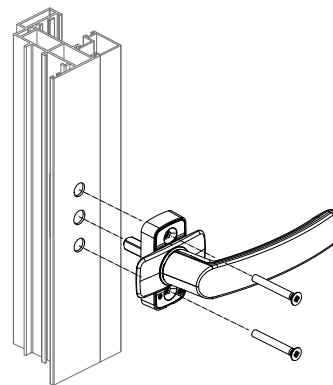

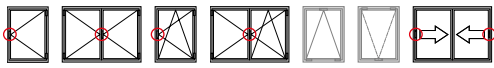

## MANILLAS POLARIS SLIM SLIM POLARIS HANDLES

Slim handles for side-hung, tilt & turn or sliding windows.

- The POLARIS SLIM handle is envisaged as the ideal solution for installations of doors where the shutters do not leave the space necessary for the mounting of a traditional handle.
- The handles are valid for gearboxes and multipoint locks.
- The handles are supplied with an integrated rotary scutcheon significantly reduces handle installation times.

Manillas slim para ventanas practicables, oscilobatientes o correderas.

- La manilla POLARIS SLIM es la solución ideal para instalaciones en puertas en donde la persiana no habilita el espacio necesario para el montaje de una manilla tradicional.
- Las manillas son válidas para caja de transmisión y cierre multipunto.
- Las manillas se suministran con escudo giratorio integrado que reduce notablemente los tiempos de instalación.

### MANILLA POLARIS SLIM POLARIS SLIM HANDLE



□ 7 x 27 mm

S5771S

\*\*

10

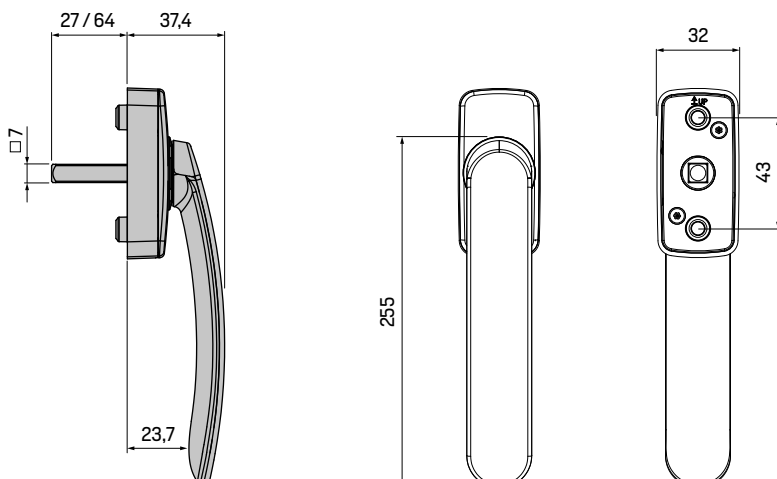
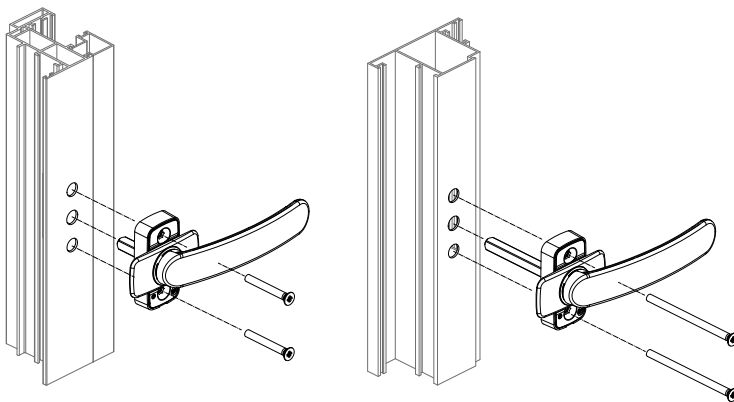

### MANILLA DE APERTURA EXTERIOR POLARIS SLIM POLARIS SLIM OUTWARD OPENING HANDLE



□ 7 x 64 mm

S5775S

\*\*

10



# MANILLA POLARIS XXL

XXL POLARIS HANDLE

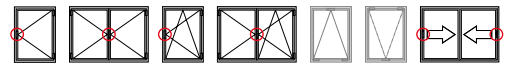

## MANILLA POLARIS XXL

XXL POLARIS HANDLE

S5777 \*\*

20



- \*\*
- 
- AL ZM
- POM AC
- 
- 
- 7 mm
- allen2,5
- PH2

Manilla de longitud especial compatible con sistemas de ventanas practicables, oscilobatientes o correderas.

- Longitud especial de la maneta que facilita el accionamiento del herraje.
- Reducción de hasta un 50% la fuerza necesaria para mover el herraje.
- La manilla es válida para caja de transmisión y cierre multipunto.
- La manilla se suministra con escudo giratorio integrado que reduce notablemente los tiempos de instalación.

Special handle length compatible with side-hung, tilt & turn or sliding window systems.

- Special length of the handle that facilitates the operation of the hardware.
- Reduces the force required to move the hardware by up to 50%.
- The handle is valid for gearbox and multipoint lock.
- The handle is supplied with an integrated rotary scutcheon significantly reduces handle installation times.

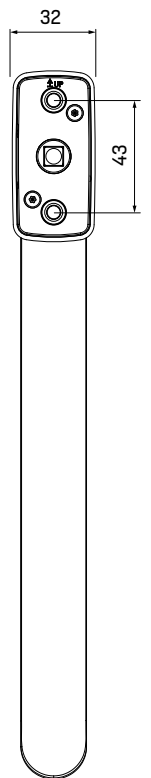
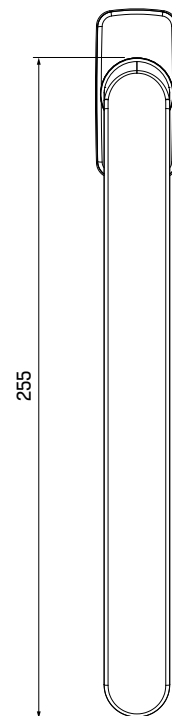
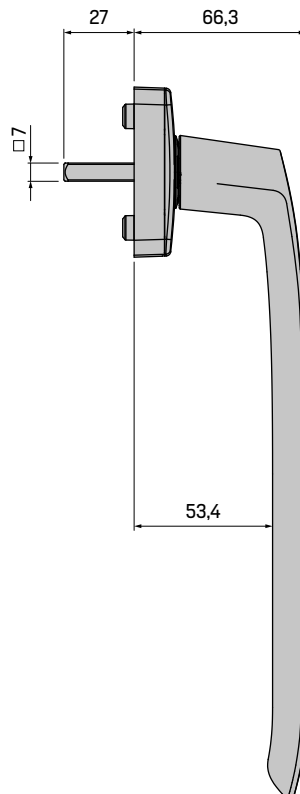
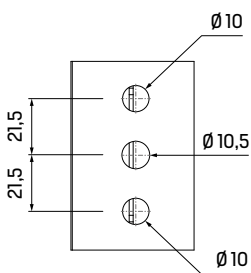
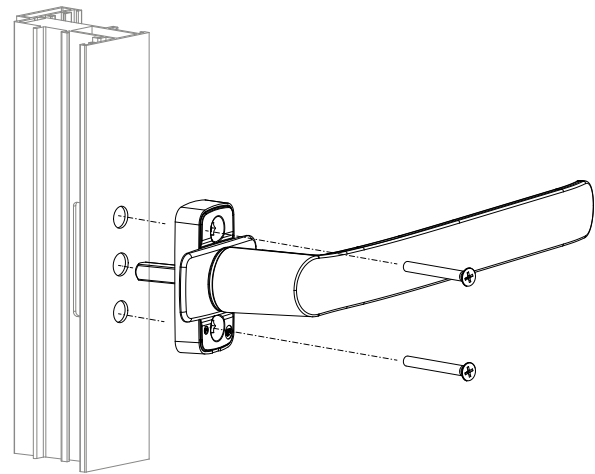

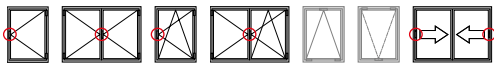

## MANILLAS POLARIS BLOCK

### POLARIS BLOCK HANDLES

Window handles with key lock compatible with side-hung, tilt & turn or sliding openings.

- The handle is valid for gearbox and multipoint lock.
- The handle is supplied with an integrated rotary scutcheon significantly reduces handle installation times.
- The handle is locked with a button and unlocked with a key.

Manillas de ventana con llave compatibles con aperturas practicables, oscilobatientes y correderas.

- La manilla es válida para caja de transmisión y cierre multipunto.
- La manilla se suministra con escudo giratorio integrado que reduce notablemente los tiempos de instalación.
- El bloqueo de la manilla se realiza con botón y el desbloqueo mediante llave.

## MANILLAS POLARIS BLOCK

### POLARIS BLOCK HANDLES



□ 7x27 mm

S5773 \*\*

□ 7x64 mm

S5779 \*\*

20

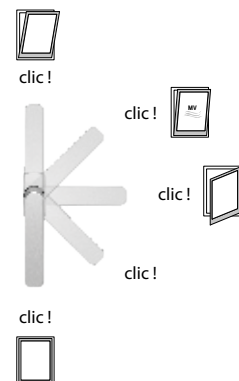
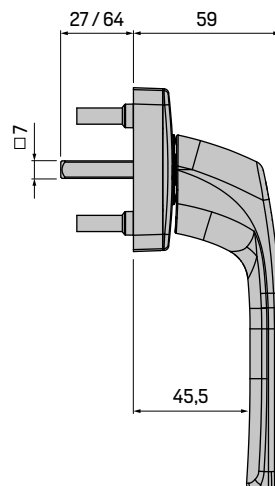
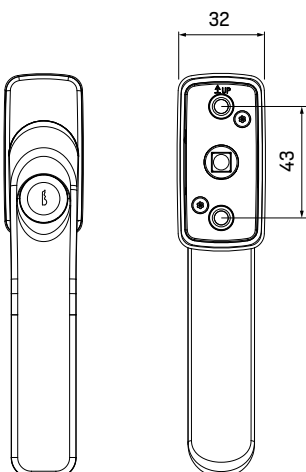
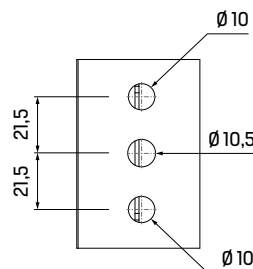
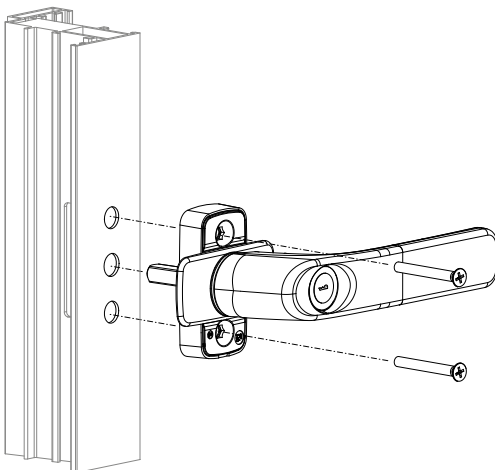
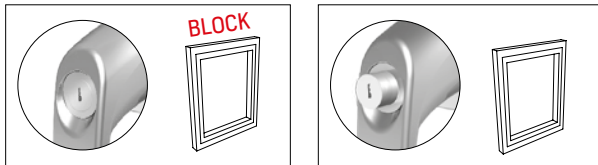

Indicación sonora de las posiciones de la manilla  
Audible indication of handle positions

## MANILLA ALTAIR ALTAIR HANDLE

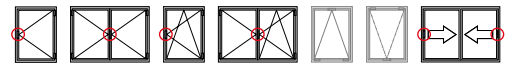

## MANILLA ALTAIR ALTAIR HANDLE

0771 \*\* R

15



## KIT DE TORNILLERÍA DE SEGURIDAD SECURITY SCREW KIT

A0507140

50



Manilla reforzada para ventanas practi- cables, oscilobatientes y correderas.

- La manilla es válida para caja de transmisión y cierre multipunto.
- La doble fijación de la manilla al perfil y al herraje permite evitar deformaciones y dota de gran estabilidad y refuerzo al sistema de cierre.
- Disponible kit de tornillos de seguridad para doble manilla que impiden manipular el herraje desde el exterior (referencia **A0507140**).
- La fijación al perfil se realiza mediante tornillos autotaladrantes sin necesidad de realizar mecanizados adicionales.
- La manilla es apta para la incorporación de remaches roscados para fijación al perfil por medio de tornillos de rosca métrica.
- Para aplicaciones especiales hay disponibles diferentes medidas de cuadradillo.

Reinforced handle for side-hung, tilt & turn windows and sliding windows.

- The handle is valid for gearbox and multipoint lock.
- The double fixing of the handle to the profile and to the hardware prevents deformation and gives great stability and reinforcement to the locking system.
- Security screw kit available for double handle that prevent manipulation of the hardware from the outside (reference **A0507140**).
- The fixation to the profile is made by means of self-drilling screws without the need of additional mechanizations.
- The handle is suitable for the incorporation of threaded rivets for attachment to the profile by means of metric-threaded screws.
- For special applications different spindle lengths are available.

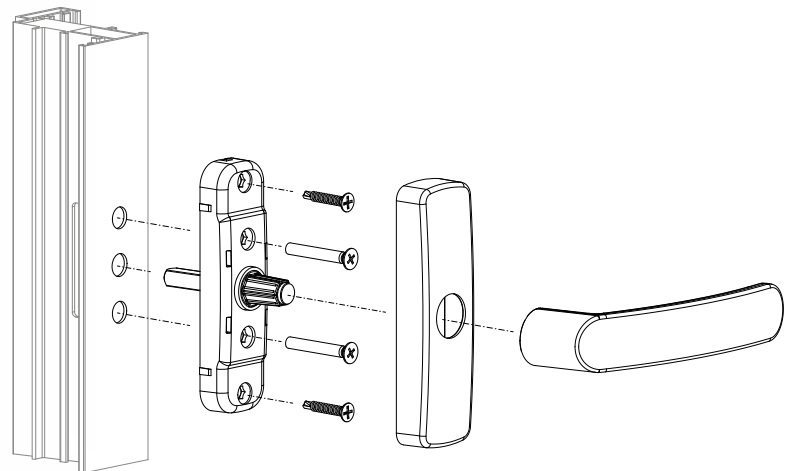

**D ≤ 55 mm**

**CUADRADILLO SPINDLE** 7x80 mm

**TORNILLERÍA SCREWS** M4x65 mm

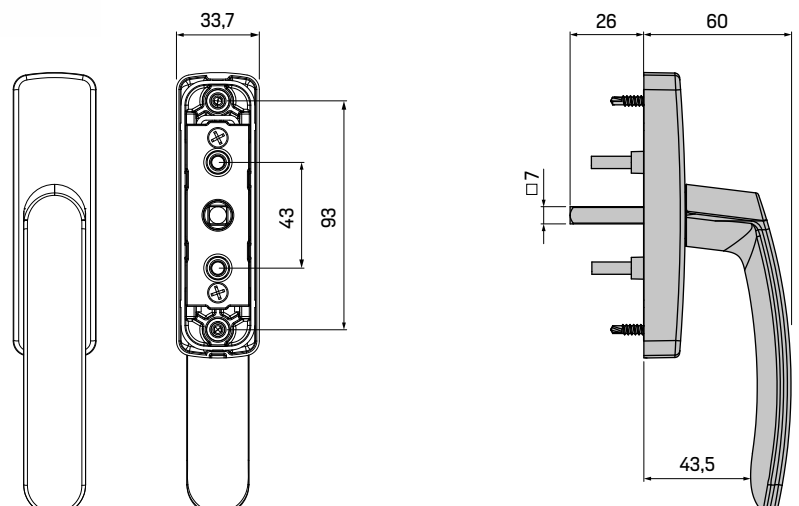

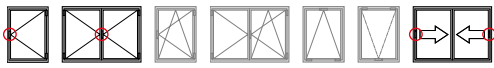

Reinforced offset handles for sliding windows with single point or multipoint locking systems.

- The handle is valid for gearbox and multipoint lock.
- The double fixing of the handle to the profile and to the hardware prevents deformation and gives great stability and reinforcement to the locking system.
- Security screw kit available for double handle that prevent manipulation of the hardware from the outside (reference **A0507140**).
- The fixation to the profile is made by means of self-drilling screws without the need of additional mechanizations.
- The handles are suitable for the incorporation of threaded rivets for attachment to the profile by means of metric-threaded screws.

**ALTAIR + offset handle**

- Handle more extended outward to avoid catching on the central profile.

Manillas acodadas reforzadas para ventanas correderas con sistemas de cierre monopunto o multipunto.

- La manilla es válida para caja de transmisión y cierre multipunto.
- La doble fijación de la manilla al perfil y al herraje permite evitar deformaciones y dota de gran estabilidad y refuerzo al sistema de cierre.
- Disponible kit de tornillos de seguridad para doble manilla que impiden manipular el herraje desde el exterior (referencia **A0507140**).
- La fijación al perfil se realiza mediante tornillos autotaladrantes sin necesidad de realizar mecanizados adicionales.
- Las manillas son aptas para la incorporación de remaches roscados para fijación al perfil por medio de tornillos de rosca métrica.

**Manilla acodada ALTAIR +**

- La maneta es más alta para evitar golpes contra el perfil del nudo central.

**MANILLA ACODADA ALTAIR**  
ALTAIR OFFSET HANDLE

\*\*

RAL

AL ZM

POM AC

7 mm

allen2,5

PH2

**Derecha**  
Right

B0777	**	R
-------	----	---

**Izquierda**  
Left

B0778	**	R
-------	----	---



**MANILLA ACODADA ALTAIR +**  
ALTAIR + OFFSET HANDLE

\*\*

RAL

AL ZM

POM AC

7 mm

allen2,5

PH2

**Derecha**  
Right

P0777	**	R
-------	----	---

**Izquierda**  
Left

P0778	**	R
-------	----	---

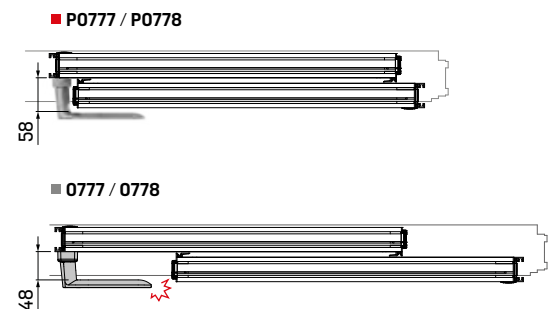
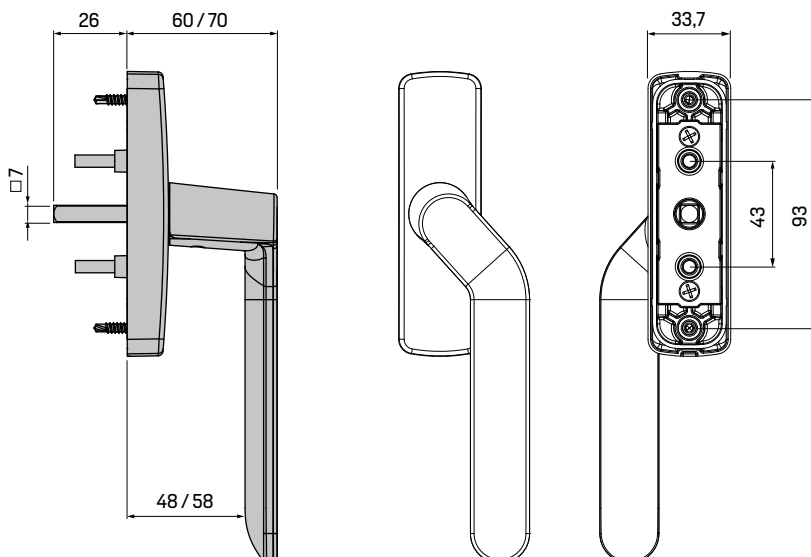
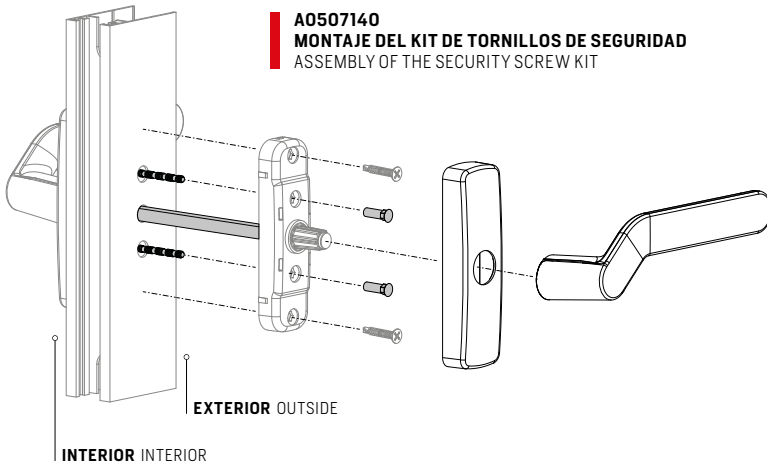



# CREMONAS LEO PARA APERTURA PRACTICABLE

## SIDE-HUNG WINDOW LEO CREMONES

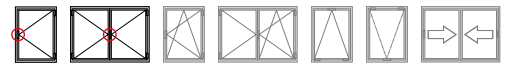

### CREMONA PRACTICABLE LEO

#### LEO SIDE-HUNG CREMONE

0710 \*\*

25



Cremonas para ventanas practicables.

- Las referencias son suministradas para apertura a derechas pero se pueden pasar a izquierdas cambiando la posición de las palas de transmisión.
- Las palas y los piñones de las cremonas se han fabricado en acero.

Cremones for side-hung windows.

- The references are supplied for right-handed opening but can be easily moved to the left-handed by changing the position of the transmission levers.
- The levers and pinions of the cremones are made of steel.

### CREMONAS A LA FRANCESA LEO

#### LEO FRENCH STYLE CREMONES

0760 \*\*

P0760 \*\*

25

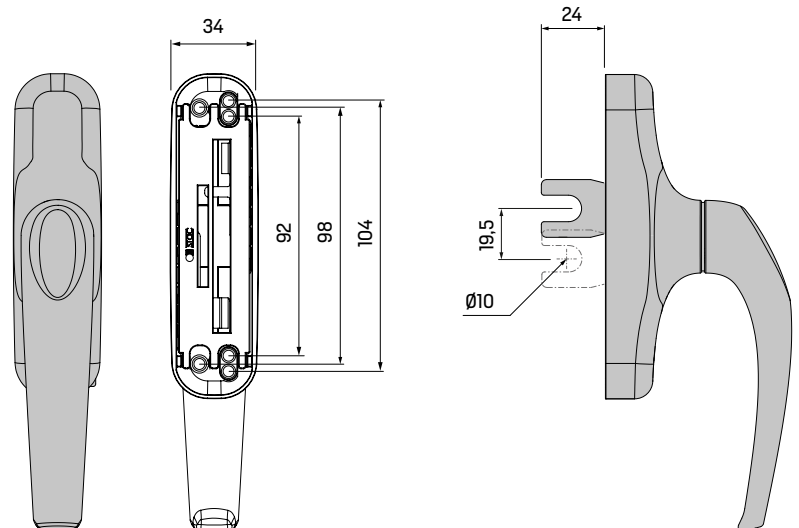
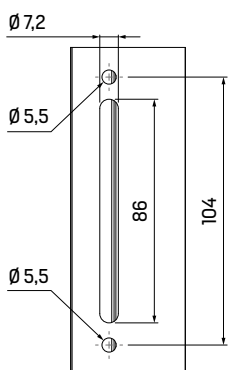
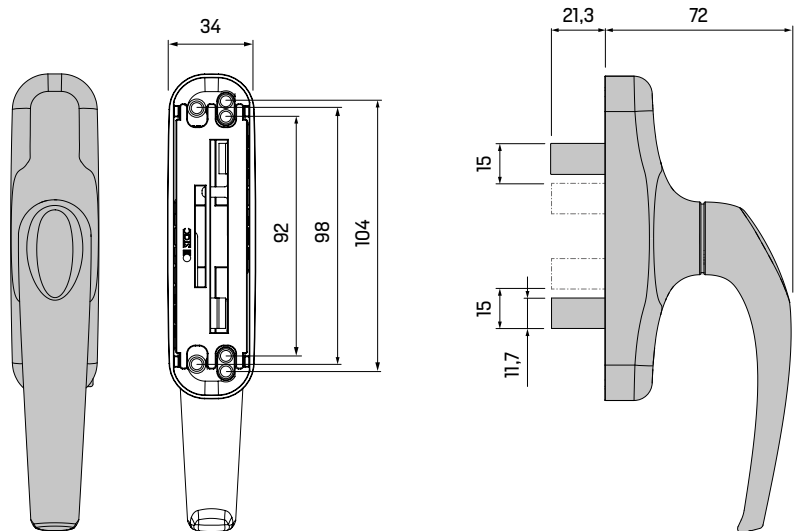

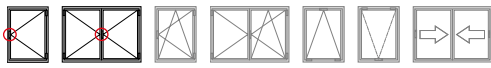

## CREMONA CUADRADA LEO PARA APERTURA PRACTICABLE

SIDE-HUNG WINDOW LEO SQUARE CREMONE

Cremones for side-hung windows.

- The references are supplied for right-handed opening but can be easily moved to the left-handed by changing the position of the transmission levers.
- The levers and pinions of the cremone are made of steel.

Cremonas para ventanas practicables.

- Las referencias son suministradas para apertura a derechas pero se pueden pasar a izquierdas cambiando la posición de las palas de transmisión.
- Las palas y los piñones de las cremonas se han fabricado en acero.

## CREMONA CUADRADA PRACTICABLE LEO

LEO SIDE-HUNG SQUARE CREMONE



0720 \*\*

25

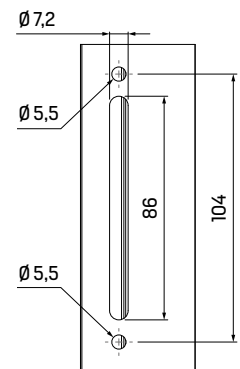
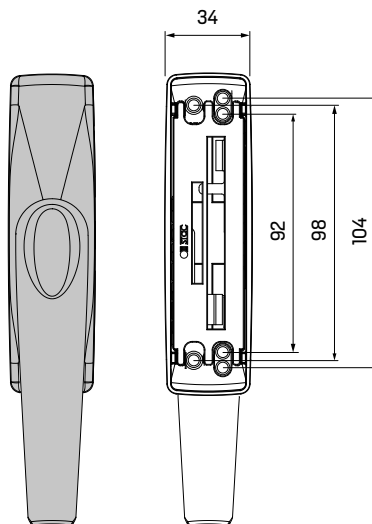
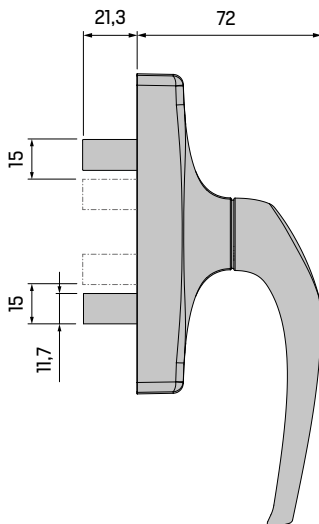
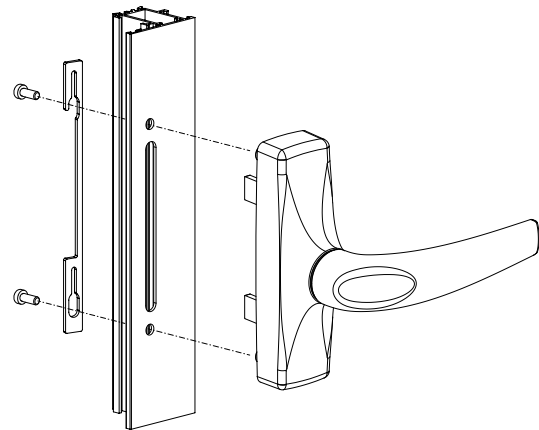
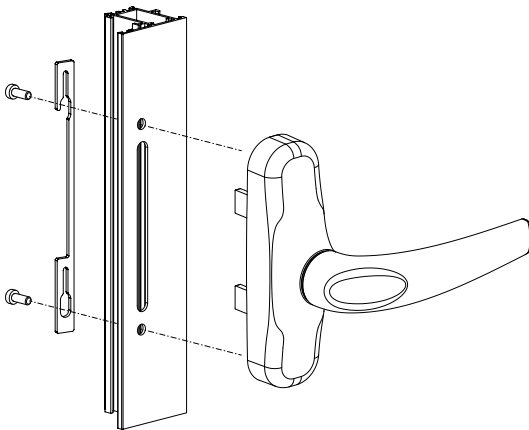

# CREMONA LEO BLOCK PARA APERTURA PRACTICABLE

SIDE-HUNG WINDOW LEO BLOCK CREMONE

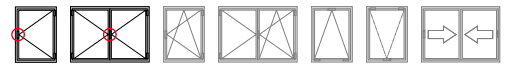

## CREMONA PRACTICABLE LEO BLOCK

LEO SIDE-HUNG BLOCK CREMONE

0730 \*\*

20



Cremona de ventana con llave compatibles con aperturas practicables.

- El bloqueo de la maneta de la cremone se realiza mediante llave.
- La cremone LEO BLOCK se suministra para apertura a derechas pero se puede pasar a izquierdas cambiando la posición de las palas de transmisión.
- La cremone es compatible con el sistema de fijación rápida FAST.
- Las palas y el piñón de la cremone se han fabricado en acero.

Window cremone with key lock compatible with side-hung openings.

- The lock of the cremone handle is done by means of a key.
- The LEO BLOCK cremone is supplied for right-handed opening but can be easily moved to the left-handed by changing the position of the transmission levers.
- The cremone is compatible with the FAST quick fastening system.
- The levers and the pinion of the cremone are made of steel.

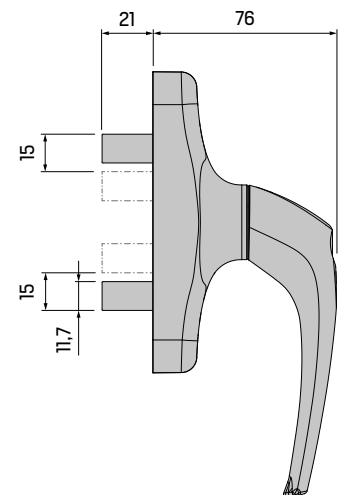
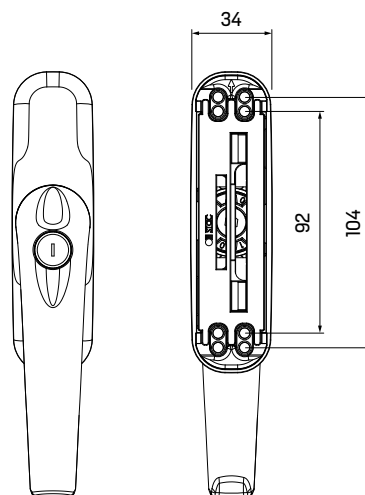
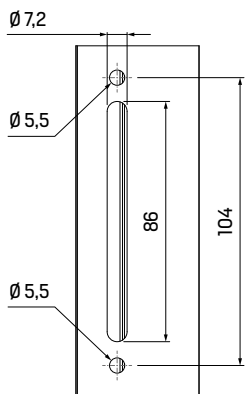
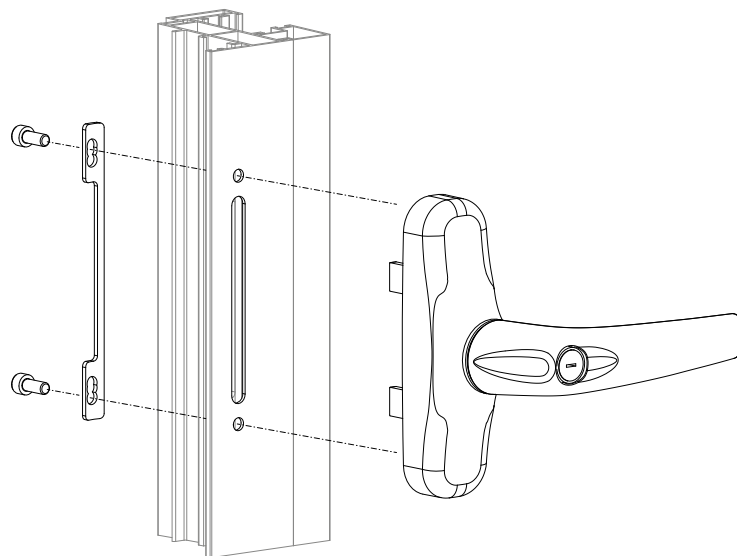

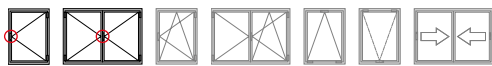

## CREMONAS EXTRAÍBLES LEO PARA APERTURA PRACTICABLE

SIDE-HUNG WINDOW LEO DETACHABLE CREMONES

Cremona with removable handle for side-hung windows.

Cremonas con manilla extraíble para ventanas practicables.

- Cremona specially designed for installation in public places where opening to the outside world must be controlled (public schools, hospitals,...).
- When the handle is removed, the movement of the cremona is disabled, preventing the window from being opened either from the inside or from the outside.
- The levers and the pinion of the cremona are made of steel.

- Cremona especialmente diseñada para su uso en locales pública concurrencia donde la apertura exterior debe ser controlada (centros públicos de enseñanza, hospitales,...).
- Al extraer la manilla el movimiento de la cremona queda inutilizado impidiendo que la ventana pueda ser abierta ya sea desde el interior o desde el exterior.
- Las palas y el piñón de la cremona se han fabricado en acero.

### ■ CREMONA LEO EXTRAÍBLE DETACHABLE LEO CREMONE

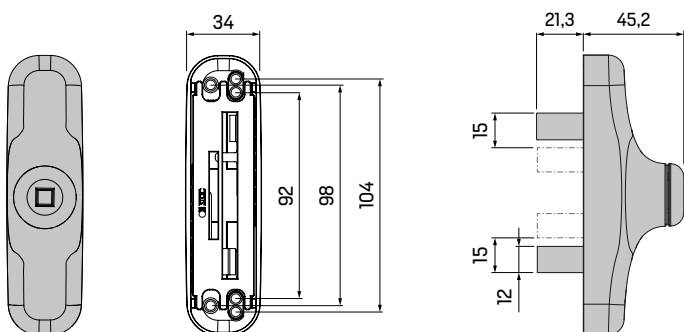

### ■ CREMONA CUADRADA LEO EXTRAÍBLE DETACHABLE LEO SQUARE CREMONE

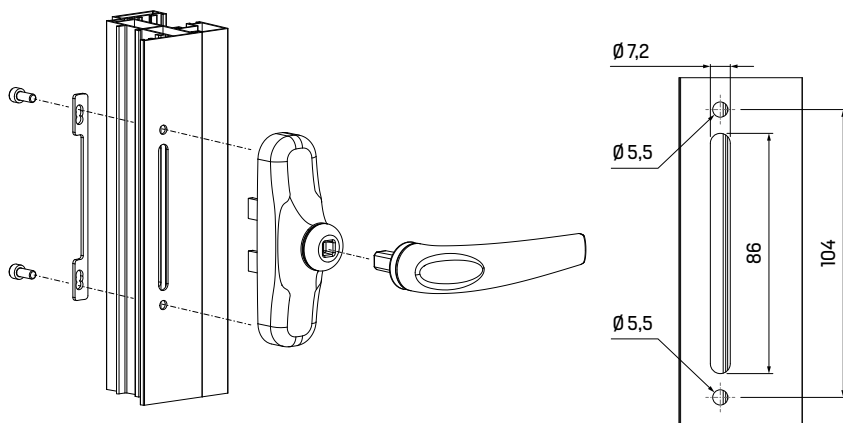
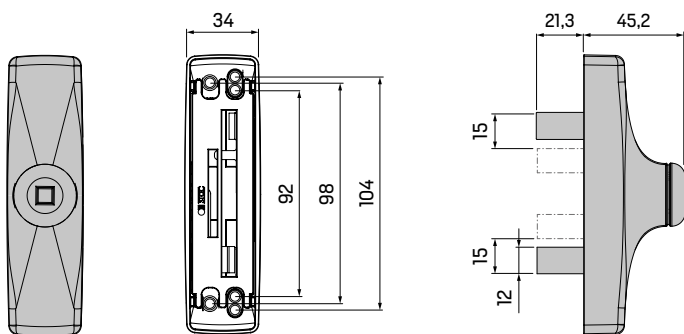

### CREMONA EXTRAÍBLE LEO LEO DETACHABLE CREMONE



0711 \*\*

25



### CREMONA CUADRADA EXTRAÍBLE LEO LEO DETACHABLE SQUARE CREMONE



0721 \*\*

25



### MANETA EXTRAÍBLE LEO LEO DETACHABLE HANDLE



0507078 \*\*

1



# CREMONAS LYRA PARA APERTURA OSCILOBATIENTE

TILT & TURN WINDOW LYRA CREMONES

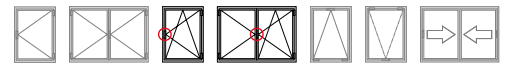

## CREMONAS OSCILOBATIENTES LYRA

LYRA TILT & TURN CREMONES

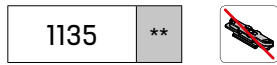
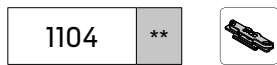

Cremonas de ventana compatibles con aperturas oscilobatientes.

- La cremona LYRA se puede utilizar en ventanas practicables limitando el giro de la misma a 90° realizando una sencilla maniobra.
- La transmisión del movimiento hacia las fallebas se realiza mediante funda o con remaches en la propia falleba.
- La cremona es compatible con el sistema de fijación rápida FAST.
- Las palas y el piñón de la cremona se han fabricado en acero.

Window cremones compatible with tilt & turn openings.

- The cremone LYRA can be used on side-hung windows by limiting the turn of the cremone to 90° with a simple manoeuvre.
- The transmission of the movement to the rods is made by the transmission cover or by rivets on the rod itself.
- The cremone is compatible with the FAST quick fastening system.
- The levers and the pinion of the cremone are made of steel.

## FUNDA DE TRANSMISIÓN

TRANSMISSION COVER

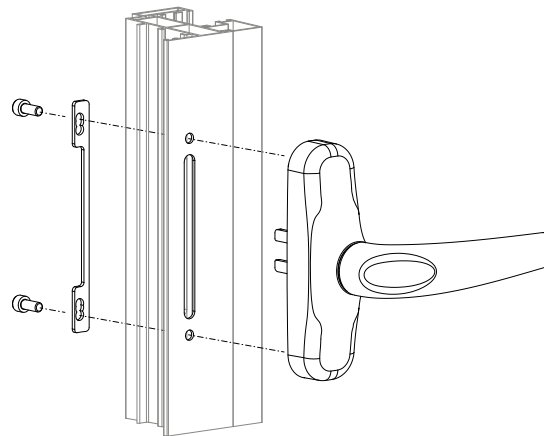
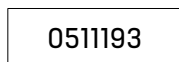

**Por defecto, las cremonas son suministradas con funda de transmisión, si no se indica lo contrario.**

By default, cremones are supplied with a transmission cover, unless otherwise indicated.

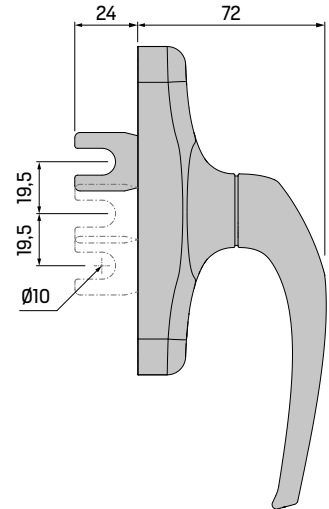
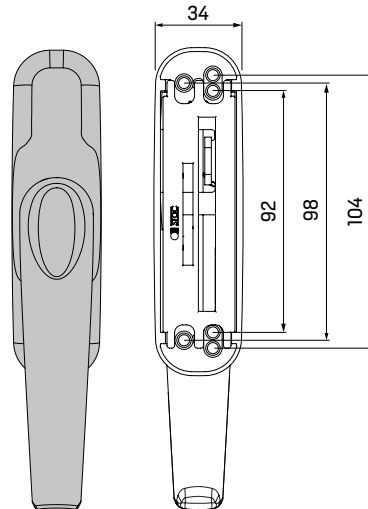
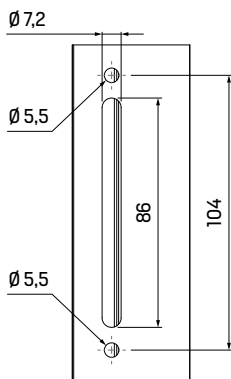

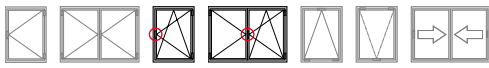

## CREMONAS CUADRADAS LYRA PARA APERTURA OSCILOBATIENTE

TILT & TURN WINDOW LYRA SQUARE CREMONES

Window cremones compatible with tilt & turn openings.

- The cremone LYRA can be used on side-hung windows by limiting the turn of the cremone to 90° with a simple manoeuvre.
- The transmission of the movement to the rods is made by the transmission cover or by rivets on the rod itself.
- The cremone is compatible with the FAST quick fastening system.
- The levers and the pinion of the cremone are made of steel.

Cremonas de ventana compatibles con aperturas oscilobatientes.

- La cremona LYRA se puede utilizar en ventanas practicables limitando el giro de la misma a 90° realizando una sencilla maniobra.
- La transmisión del movimiento hacia las fallebas se realiza mediante funda o con remaches en la propia falleba.
- La cremona es compatible con el sistema de fijación rápida FAST.
- Las palas y el piñón de la cremona se han fabricado en acero.

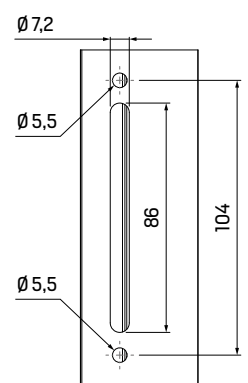
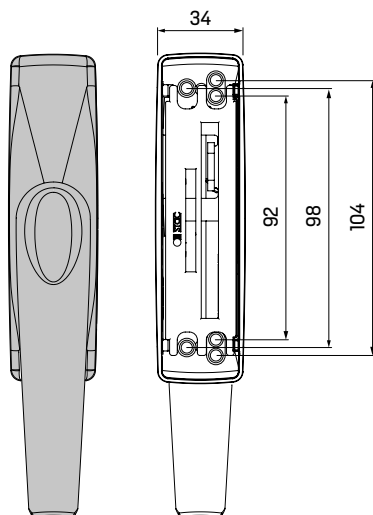
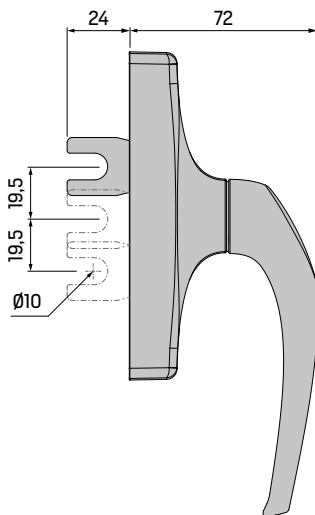
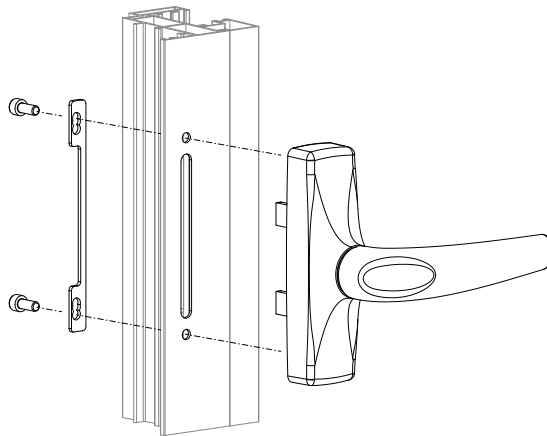

## CREMONAS CUADRADAS OSCILOBATIENTES LYRA

LYRA TILT & TURN SQUARE CREMONES



1124 \*\*



1135 \*\* C

25



### FUNDA DE TRANSMISIÓN

TRANSMISSION COVER

PA

0511193



200

**Por defecto, las cremonas son suministradas con funda de transmisión, si no se indica lo contrario.**

By default, cremones are supplied with a transmission cover, unless otherwise indicated.

# CREMONA LYRA BLOCK PARA APERTURA OSCILOBATIENTE

TILT & TURN WINDOW LYRA BLOCK CREMONE

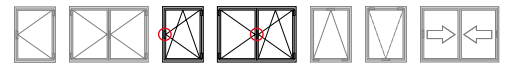

## CREMONA OSCILOBATIENTE LYRA BLOCK

LYRA BLOCK TILT & TURN CREMONE

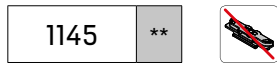
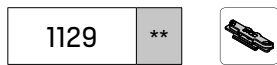

Cremonas de ventana con llave compatibles con aperturas oscilobatientes.

- El bloqueo de la maneta de la cremona se realiza mediante llave.
- En ventanas con maniobra lógica existen dos posiciones de bloqueo:
  - girando la llave 90°**, la cremona permite oscilar pero no abrir la ventana.
  - girando la llave 180°**, la cremona se bloquea impidiendo tanto abrir como oscilar la ventana.
- La cremona LYRA BLOCK se puede utilizar en ventanas practicables limitando el giro de la misma a 90° realizando una sencilla maniobra.

Notas técnicas al final del capítulo.

Window cremones with key lock compatible with tilt & turn openings.

- The lock of the cremone handle is done by means of a key.
- There are two locking positions for tilt-before-turn windows:
  - turning key 90°**, the cremone allows to tilt but not to open the window.
  - turning key 180°**, the cremone is blocked, preventing both opening and tilting the window.
- The cremone LYRA BLOCK can be used on side-hung windows by limiting the turn of the cremone to 90° with a simple manoeuvre.

Technical notes at the end of the chapter.

## FUNDA DE TRANSMISIÓN

TRANSMISSION COVER

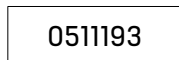

Por defecto, las cremonas son suministradas con funda de transmisión, si no se indica lo contrario.

By default, cremones are supplied with a transmission cover, unless otherwise indicated.

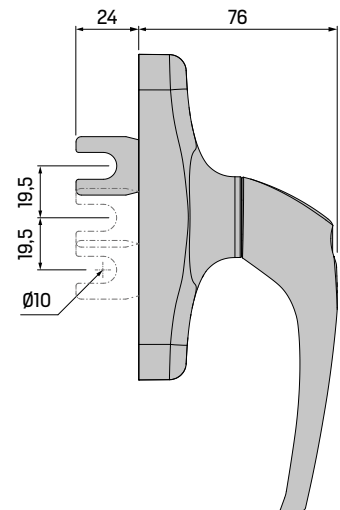
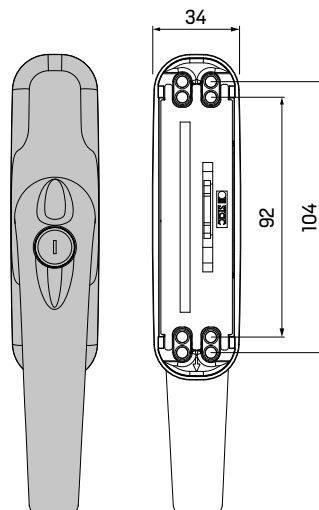
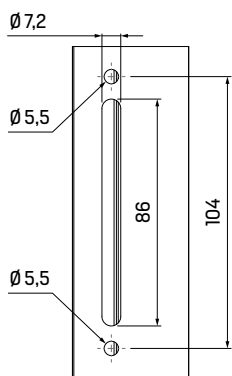
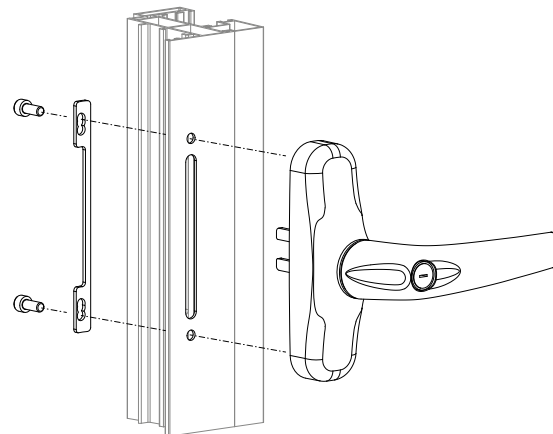



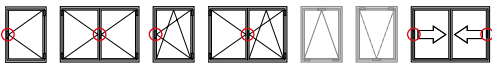

## MANILLAS LYRA BOX

### LYRA BOX HANDLES

Handles for side-hung, tilt & turn or sliding windows.

- The handles are compatible with gear-boxes and multipoint locks.
- The handles are supplied with an integrated rotary scutcheon significantly reduces handle installation times.

Manillas para ventanas practicables, oscilobatientes o correderas.

- Las manillas son compatibles con caja de transmisión y cierres multipunto.
- Las manillas se suministran con escudo giratorio integrado que reduce notablemente los tiempos de instalación.

## MANILLAS LYRA BOX

### LYRA BOX HANDLES



□ 7 x 27 mm

0770

\*\*

□ 7 x 60 mm

P0770

\*\*

25

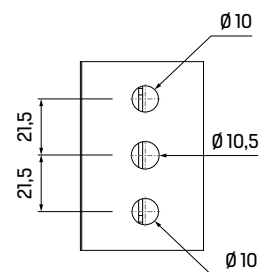
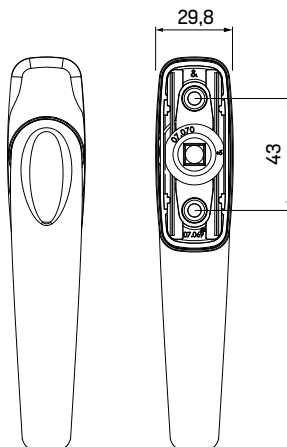
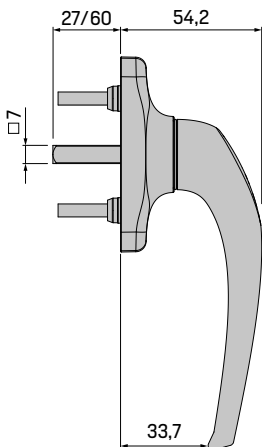
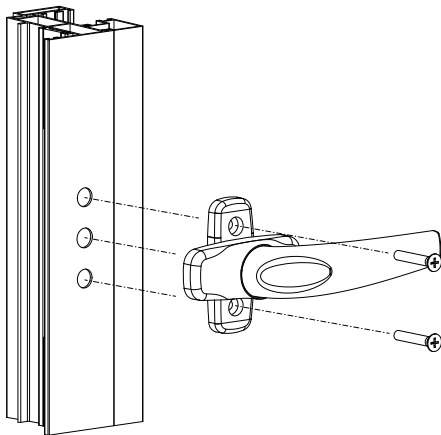

## CREMONAS EXTRAÍBLES LYRA

LYRA DETACHABLE CREMONES

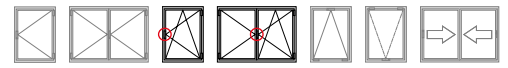

## CREMONAS EXTRAÍBLES LYRA

LYRA DETACHABLE CREMONES



Cremonas con manilla extraíble compatibles con ventanas oscilobatientes.

- Cremona especialmente diseñada para su uso en locales pública concurrencia donde la apertura exterior debe ser controlada (centros públicos de enseñanza, hospitales,...).
- La cremona proporciona mayor seguridad a los sistemas de apertura evitando el accionamiento y posible fuerza de la manilla.
- Al extraer la manilla el movimiento de la cremona queda inutilizado impidiendo que la ventana pueda ser abierta ya sea desde el interior o desde el exterior.
- Se puede utilizar en ventanas practicable limitando el giro de la misma a 90° realizando una sencilla maniobra.

Cremones with removable handle for tilt & turn windows.

- Cremona specially designed for installation in public places where opening to the outside world must be controlled (public schools, hospitals,...).
- The cremona provides greater security to the opening systems by avoiding the activation and possible force of the handle.
- When the handle is removed, the movement of the cremona is disabled, preventing the window from being opened either from the inside or from the outside.
- It can be used on side-hung windows by limiting the turn of the cremona to 90° with a simple manoeuvre.

## MANETA EXTRAÍBLE LEO

LEO DETACHABLE HANDLE

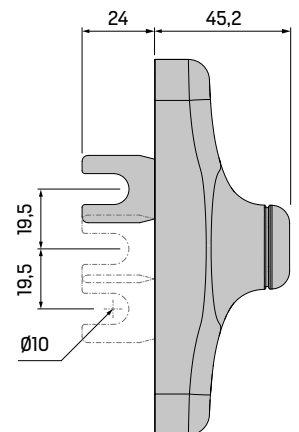
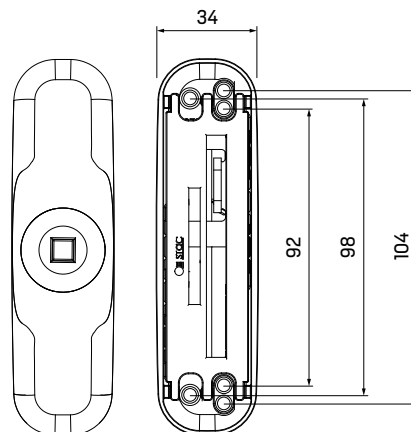
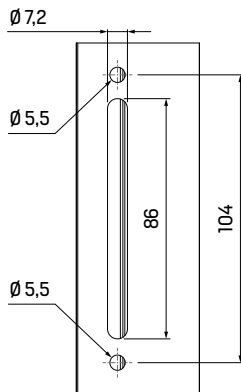
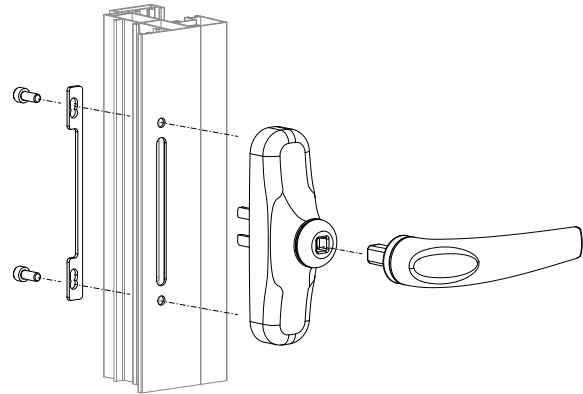
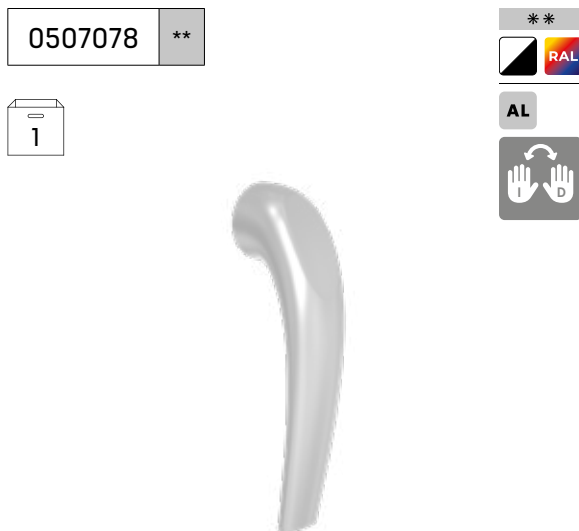

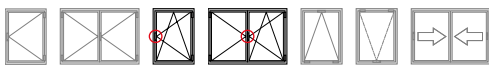

## CREMONAS CUADRADAS EXTRAÍBLES LYRA

### LYRA DETACHABLE SQUARE CREMONES

Cremones with removable handle for tilt & turn windows.

- Cremones specially designed for installation in public places where opening to the outside world must be controlled (public schools, hospitals,...).
- The cremone provides greater security to the opening systems by avoiding the activation and possible force of the handle.
- When the handle is removed, the movement of the cremone is disabled, preventing the window from being opened either from the inside or from the outside.
- It can be used on side-hung windows by limiting the turn of the cremone to 90° with a simple manoeuvre.

Cremonas con manilla extraíble compatibles con ventanas oscilobatientes.

- Cremona especialmente diseñada para su uso en locales pública concurrencia donde la apertura exterior debe ser controlada (centros públicos de enseñanza, hospitales,...).
- La cremona proporciona mayor seguridad a los sistemas de apertura evitando el accionamiento y posible fuerza de la manilla.
- Al extraer la manilla el movimiento de la cremona queda inutilizado impidiendo que la ventana pueda ser abierta ya sea desde el interior o desde el exterior.
- Se puede utilizar en ventanas practicales limitando el giro de la misma a 90° realizando una sencilla maniobra.

## CREMONAS CUADRADAS EXTRAÍBLES LYRA

### LYRA DETACHABLE SQUARE CREMONES

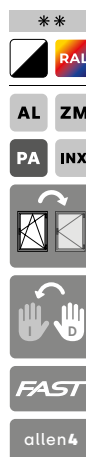

11041C \*\*



11351C \*\*



25

## FUNDA DE TRANSMISIÓN

### TRANSMISSION COVER

PA

0511193



200

**Por defecto, las cremonas son suministradas con funda de transmisión, si no se indica lo contrario.**

By default, cremones are supplied with a transmission cover, unless otherwise indicated.

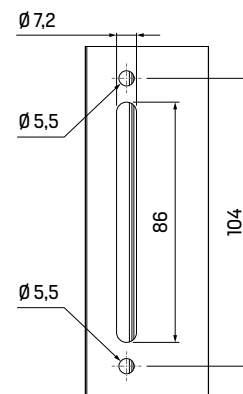
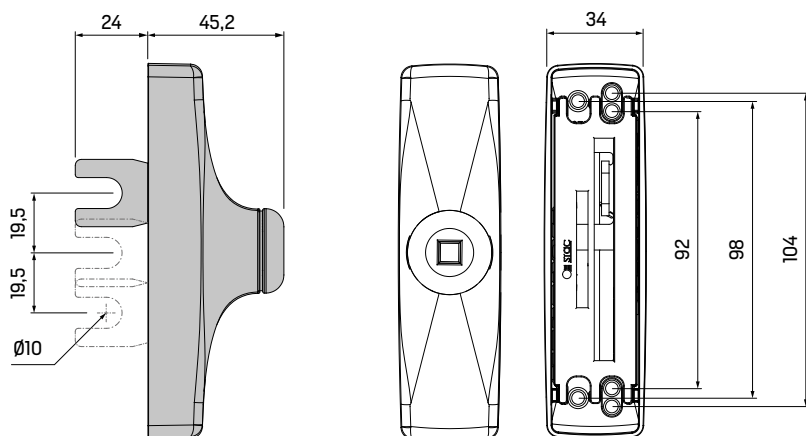
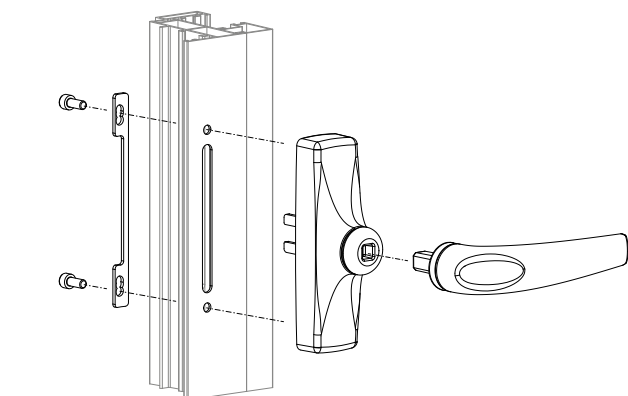



# línea **ATRIA**

**correderas elevables** lift & slide



**Versiónes con / sin llave**  
Versions with or w/o lock

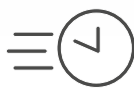

**Instalación simple y rápida**  
Simple & quick installation



**Acabados anodizados**  
Anodized finishes



**Robustez contrastada**  
Tested robustness

Actualmente, el mercado del cerramiento arquitectónico demanda sistemas de corredera elevable con menor sección visible de perfil que permitan mayor superficie de acristalamiento, mejora de las prestaciones en huecos de gran tamaño, fácil maniobrabilidad y sobre todo que proporcionen al usuario el máximo confort y seguridad posibles. La gama ATRIA que aporta soluciones que permiten conformar sistemas de corredera elevable de altas prestaciones. En el diseño, se ha cuidado al máximo la ergonomía de uso para facilitar la manipulación y maniobra de hojas de grandes dimensiones y pesos.

## » Uñero y manillones

La gama ATRIA está constituida por un manillón que permite el accionamiento y elevación de la corredera y un uñero que permite el movimiento de la hoja de forma fácil e intuitiva desde el exterior de la ventana.

- **El manillón dispone de dos versiones:** con cerradura / sin cerradura.
- **Los manillones son desmontables:** permiten la opción de servirlos en crudo para que cualquier cliente los pueda lacar y montar fácilmente.

## » Acabados lacados y anodizados

La gama ATRIA está disponible tanto en lacado blanco y negro como en la carta de colores RAL. El proceso de lacado confiere gran resistencia a la superficie de los perfiles de aluminio, protegiéndolos de la corrosión natural.

Los manillones están disponibles con acabados anodizados INOX y NATURAL. Mediante el proceso de anodizado conseguimos aumentar artificialmente el espesor de la capa natural del óxido del aluminio, logrando una gran protección contra la corrosión y aumentando considerablemente las características de resistencia y durabilidad de este material. Esto lo hace especialmente idóneo para proyectos con condiciones climáticas severas, así como proyectos en zonas costeras.

The modern architectural closure market demands lift & slide systems with less visible profile to allow a large glassed area, improved characteristics of large-scale openings, easy operation and which, most importantly, provide the user with the highest levels of comfort and security possible. The ATRIA range offers solutions to allow high-spec sliding systems to be installed. In designing the ATRIA range, special attention has been paid to the ergonomics of use to make operation and movement of large and/or heavy leaves as easy as possible.

## » Finger pull and pull handles

The ATRIA range includes a long-armed handle for operating and lifting the slider and a finger pull which allows the leaf to be moved easily and intuitively from the exterior.

- **The pull handle comes in two versions:** with lock / without lock.
- **The pull handles are detachable:** they can be provided unfinished so that any client can paint them and install them easily.

## » Lacquered and anodized finishes

The handles are available with black or white lacquered finish, as well as the entire RAL range of colours. The lacquering process provides the surface of the aluminium with great resistance and protects the metal from natural corrosion.

The pull handles are available in the INOX / NATURAL anodized finishes. Via the anodizing process we have managed to increase the depth of the natural oxide layer of the aluminium, achieving high levels of corrosion resistance and increasing the resistance and durability of the material greatly. This makes them the ideal choice for projects in harsh climates such as projects in coastal regions.

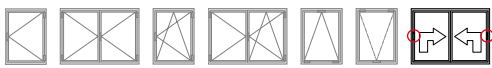

Pull handle and finger pull range for lift & slide systems.

Gama de manillón y uñero para sistemas de corredera elevable.

- The handle of the pull handles are easily removable.
- The pull handle is available in two versions: with key and without key.
- The finger handle is available in two depths: 9.5 and 18.5 mm.
- Aesthetic line harmonised with the SIRIUS, ALTAIR and POLARIS cremones and handles.
- The range is compatible with all lift and slide hardware on the market.
- The range has been tested at 25,000 cycles with satisfactory results.

- Las manetas de los manillones son fácilmente desmontables.
- El manillón está disponible en dos versiones: con llave y sin llave.
- El uñero está disponible en dos profundidades: 9,5 y 18,5 mm.
- Línea estética armonizada con las cremonas y manillas SIRIUS, ALTAIR y POLARIS.
- La gama es compatible con todos los herrajes de corredera elevable.
- La gama ha sido testada a 25.000 ciclos con resultados satisfactorios.

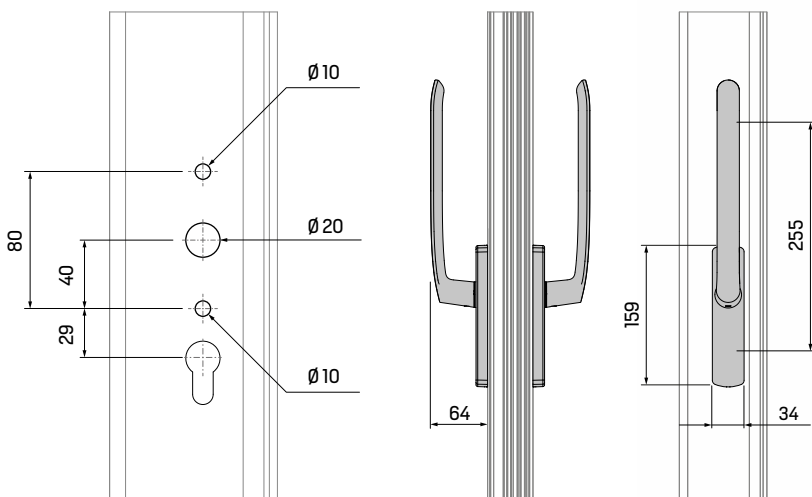
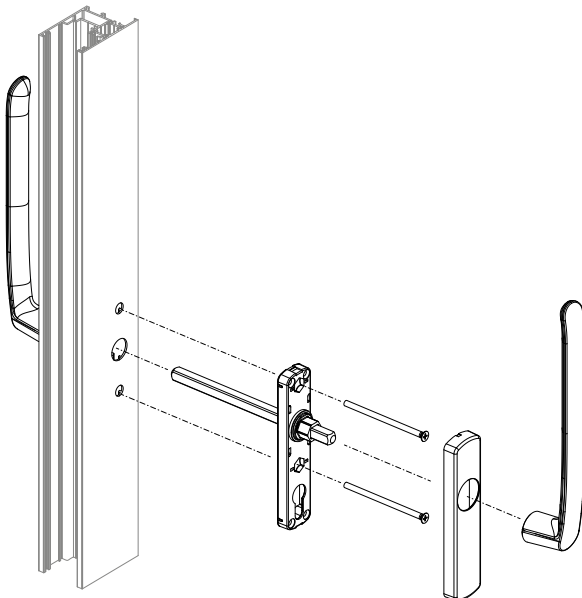

**MANILLÓN ATRIA CON LLAVE**  
ATRIA PULL HANDLE WITH KEY

\*\*

RAL

ANODIC

AL ZM

AC INX

D

10 mm

2311 \*\*



**MANILLÓN ATRIA SIN LLAVE**  
ATRIA PULL HANDLE WITHOUT KEY

\*\*

RAL

ANODIC

AL ZM

AC INX

D

10 mm

2312 \*\*



**KIT DE FIJACIÓN PARA MANILLÓN SIMPLE ATRIA**  
FIXING KIT FOR ATRIA SIMPLE PULL HANDLE

AC INX

236003



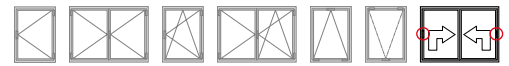

**JUEGO DE MANILLONES ATRIA CON LLAVE**  
 ATRIA PULL HANDLE SET WITH KEY

2313 \*\*



Gama de manillón y uñero para sistemas de corredera elevable.

- Las manetas de los manillones son fácilmente desmontables.
- El manillón está disponible en dos versiones: con llave y sin llave.
- El uñero está disponible en dos profundidades: 9,5 y 18,5 mm.
- Línea estética armonizada con las cremonas y manillas SIRIUS, ALTAIR y POLARIS.
- La gama es compatible con todos los herrajes de corredera elevable.
- La gama ha sido testada a 25.000 ciclos con resultados satisfactorios.

Pull handle and finger pull range for lift & slide systems.

- The handle of the pull handles are easily removable.
- The pull handle is available in two versions: with key and without key.
- The finger handle is available in two depths: 9.5 and 18.5 mm.
- Aesthetic line harmonised with the SIRIUS, ALTAIR and POLARIS cremones and handles.
- The range is compatible with all lift and slide hardware on the market.
- The range has been tested at 25,000 cycles with satisfactory results.

**JUEGO DE MANILLONES ATRIA SIN LLAVE**  
 ATRIA PULL HANDLE SET WITHOUT KEY

2314 \*\*



■ **MECANIZADOS PARA MANILLÓN** MACHINING FOR PULL HANDLE

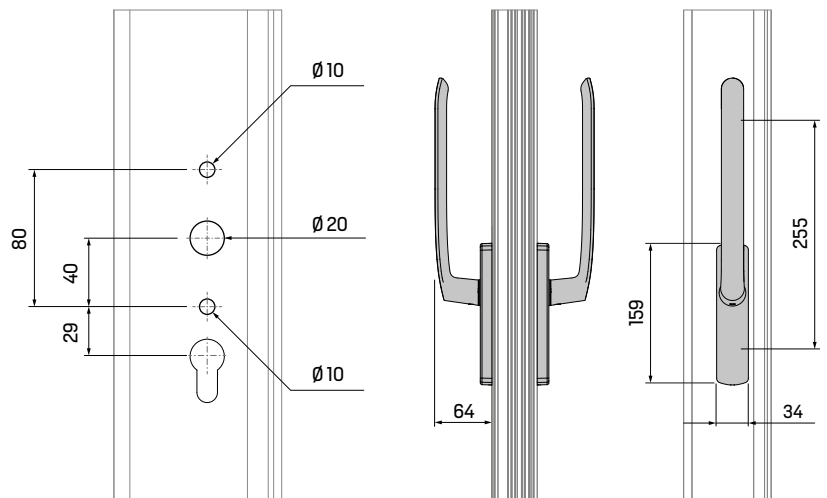

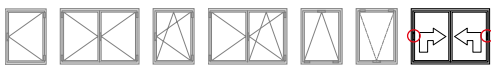

Pull handle and finger pull range for lift & slide systems.

- The handle of the pull handles are easily removable.
- The pull handle is available in two versions: with key and without key.
- The finger handle is available in two depths: 9.5 and 18.5 mm.
- Aesthetic line harmonised with the SIRIUS, ALTAIR and POLARIS cremones and handles.
- The range is compatible with all lift and slide hardware on the market.
- The range has been tested at 25,000 cycles with satisfactory results.

Gama de manillón y uñero para sistemas de corredera elevable.

- Las manetas de los manillones son fácilmente desmontables.
- El manillón está disponible en dos versiones: con llave y sin llave.
- El uñero está disponible en dos profundidades: 9,5 y 18,5 mm.
- Línea estética armonizada con las cremonas y manillas SIRIUS, ALTAIR y POLARIS.
- La gama es compatible con todos los herrajes de corredera elevable.
- La gama ha sido testada a 25.000 ciclos con resultados satisfactorios.

■ **MECANIZADOS PARA UÑERO** MACHINING FOR FINGER PULL

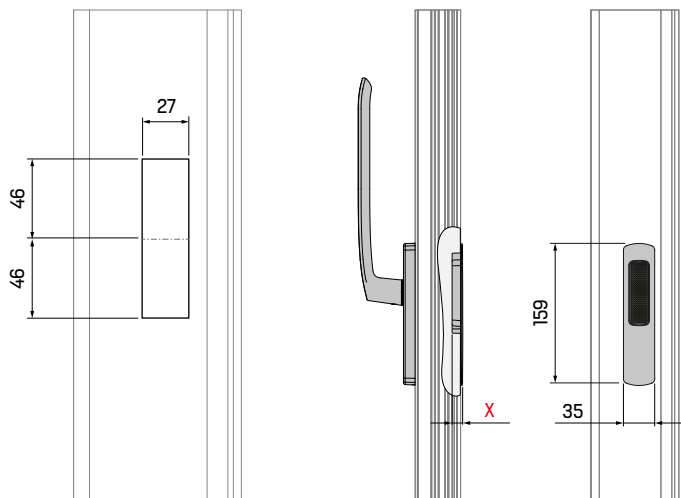

**UÑEROS: ATRIA Y ATRIA+**  
 FINGER PULLS: ATRIA & ATRIA+

**		X = 9,5 mm	2320	**
ZM		X = 18,5 mm	2322	**

**KIT JUEGO DE MANILLÓN CON LLAVE Y UÑERO ATRIA**  
 PULL HANDLE SET WITH KEY & FINGER PULL ATRIA KIT

**		<b>Con uñero ATRIA</b> With ATRIA finger pull	2315	**
AL ZM		<b>Con uñero ATRIA+</b> With ATRIA+ finger pull	2325	**

**KIT JUEGO DE MANILLÓN SIN LLAVE Y UÑERO ATRIA**  
 PULL HANDLE SET W/O KEY & FINGER PULL ATRIA KIT

**		<b>Con uñero ATRIA</b> With ATRIA finger pull	2316	**
AL ZM		<b>Con uñero ATRIA+</b> With ATRIA+ finger pull	2326	**

# KAIROX

MANILLAS EN ACERO INOX  
STAINLESS STEEL HANDLES



Acero AISI 304  
AISI 304 steel



Máxima durabilidad  
Highest durability



Microventilación  
Micro-ventilation



Variedad de diseños  
Variety of designs

El mercado del cerramiento en aluminio demanda productos más refinados desde un punto de vista tanto estético como funcional. Diseños elegantes y cuidados en donde se incorpora la última tecnología para garantizar su durabilidad. Siguiendo estas pautas, STAC ha evolucionado su línea de manillas en acero inoxidable AISI 304 con diseños modernos pero sobre todo incorporando nuevas soluciones, como la manilla KAIROX BLOCK que permite el bloqueo de la ventana mediante llave.

## » Línea completa

La línea de manillas en acero inoxidable KAIROX es totalmente compatible con todo tipo de aperturas con caja de transmisión o cierres multipunto existentes en el mercado:

- Aperturas practicables, oscilobatientes, proyectantes o abatibles
- Sistemas de ventana corredera

## » Resistencia a la corrosión

Las piezas de zamak han sido tratadas para garantizar una resistencia a la corrosión superior a 240 horas en cámara de niebla salina en cumplimiento con la norma UNE-EN 1670 obteniendo una clasificación de grado 4 que otorga una alta resistencia a la corrosión.

The modern architectural closure market is ever more demanding in terms of refinement in style and function. Elegant, meticulous design incorporating the latest technology to guarantee durability. Following these guidelines, STAC's range of AISI 304 stainless steel handles has undergone an evolution with a modern design and, above all, the incorporation of new solutions, such as the KAIROX BLOCK handle which allows the window to be blocked using a key.

## » Complete range

The KAIROX range of stainless steel handles is fully compatible with all types of openings with transmission boxes or multipoint locks on the market:

- Side-hung, tilt & turn, top-hung and bottom-hung windows
- Sliding windows

## » Corrosion resistance

The zamak pieces have been treated to guarantee corrosion resistance greater than 240 hours in a saline mist chamber in accordance with UNE-EN 1670, achieving a Grade 4 classification which ensures high resistance to corrosion.

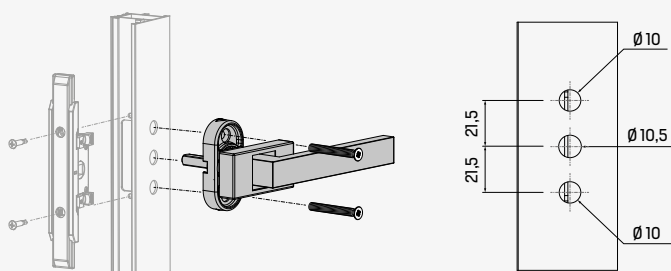



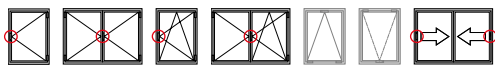

## MANILLAS KAIROX KAIROX HANDLES

Stainless steel handles compatible with side-hung, tilt & turn and sliding windows.

- The handles are compatible with gear-boxes and multipoint locks.
- Handle and cover shield made of stainless steel AISI 304.
- The handles allow the micro-ventilation position to be carried out.
- Each reference is supplied in an individual box with a 7 mm zinc-plated steel spindle and screws.
- The spindle allows two positions: inward and outward opening.

Manillas en acero inoxidable compatibles con ventanas practicables, oscilobatientes y correderas.

- Las manillas son compatibles con caja de transmisión y cierres multipunto.
- Manilla y escudo embellecedor fabricados en acero inoxidable AISI 304.
- Las manillas permiten realizar la posición de microventilación.
- Cada referencia se suministra en caja individual con cuadradillo en acero zincado de 7 mm y tornillería.
- El cuadradillo permite dos posiciones: apertura interior y apertura exterior.

### MANILLA KAIROX BLOCK KAIROX BLOCK HANDLE



260214



### MANILLA KAIROX CC KAIROX CC HANDLE



260110

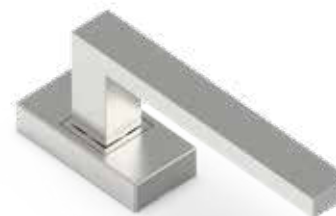

### MANILLA KAIROX CR KAIROX CR HANDLE



260310



### MANILLA KAIROX RR KAIROX RR HANDLE



260210

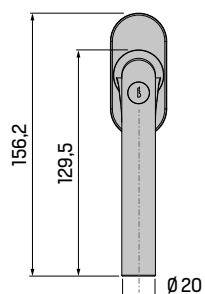
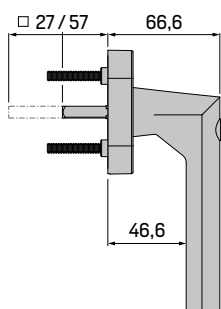

260214  
KAIROX BLOCK

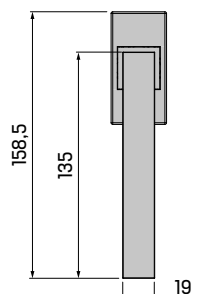
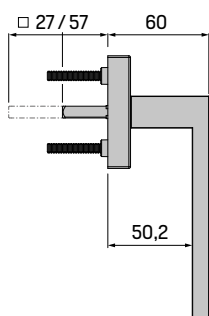

260110  
KAIROX CC

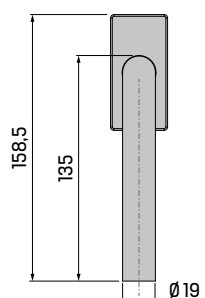
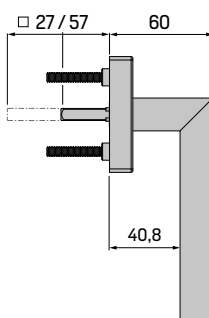

260310  
KAIROX CR

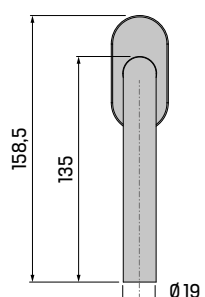
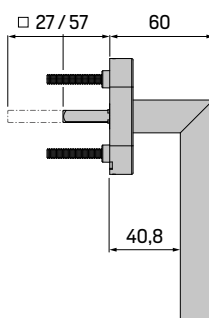

260210  
KAIROX RR

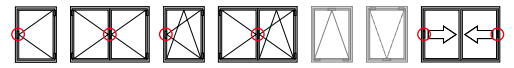

**MANILLA KAIROX CRC**  
KAIROX CRC HANDLE

260313



INX ZM



7 mm

PH2

Manillas en acero inoxidable compatibles con ventanas practicables, oscilobatientes y correderas.

- Las manillas son compatibles con caja de transmisión y cierres multipunto.
- Manilla y escudo embellecedor fabricados en acero inoxidable AISI 304.
- Las manillas permiten realizar la posición de microventilación.
- Cada referencia se suministra en caja individual con cuadradillo en acero zincado de 7 mm y tornillería.
- El cuadradillo permite dos posiciones: apertura interior y apertura exterior.

Stainless steel handles compatible with side-hung, tilt & turn and sliding windows.

- The handles are compatible with gearboxes and multipoint locks.
- Handle and cover shield made of stainless steel AISI 304.
- The handles allow the micro-ventilation position to be carried out.
- Each reference is supplied in an individual box with a 7 mm zinc-plated steel spindle and screws.
- The spindle allows two positions: inward and outward opening.

**MANILLA KAIROX RRC**  
KAIROX RRC HANDLE

260213



INX ZM



7 mm

PH2

260313  
KAIROX CRC

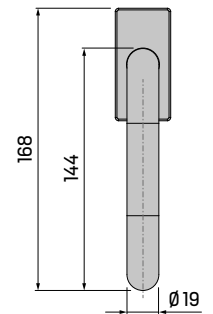
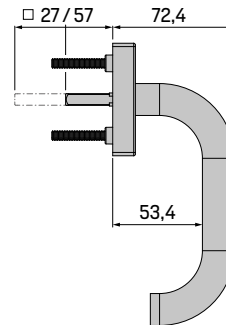

260213  
KAIROX RRC

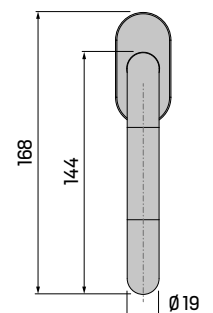
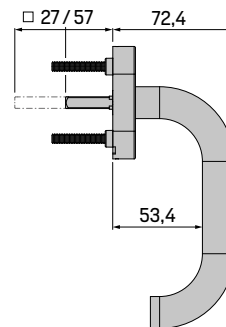

**MANILLA ACODADA KAIROX CR**  
KAIROX CR OFFSET HANDLE

260311



INX ZM



7 mm

PH2

260311  
KAIROX CR

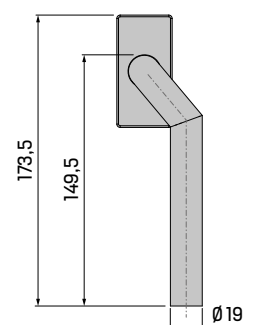
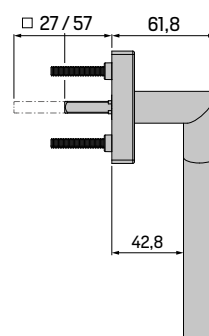

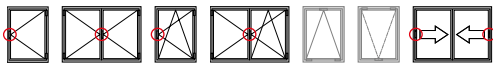

Stainless steel handles compatible with side-hung, tilt & turn and sliding windows.

- The handles are compatible with gear-boxes and multipoint locks.
- Handle and cover shield made of stainless steel AISI 304.
- The handles allow the micro-ventilation position to be carried out.
- Each reference is supplied in an individual box with a 7 mm zinc-plated steel spindle and screws.
- The spindle allows two positions: inward and outward opening.

Manillas en acero inoxidable compatibles con ventanas practicables, oscilobatientes y correderas.

- Las manillas son compatibles con caja de transmisión y cierres multipunto.
- Manilla y escudo embellecedor fabricados en acero inoxidable AISI 304.
- Las manillas permiten realizar la posición de microventilación.
- Cada referencia se suministra en caja individual con cuadradillo en acero zincado de 7 mm y tornillería.
- El cuadradillo permite dos posiciones: apertura interior y apertura exterior.

**MANILLA ACODADA KAIROX RR**  
KAIROX RR OFFSET HANDLE

INX ZM

7 mm

PH2

260211



**MANILLA ACODADA KAIROX CR**  
KAIROX CR OFFSET HANDLE

INX ZM

7 mm

PH2

260312



**MANILLA ACODADA KAIROX RR**  
KAIROX RR OFFSET HANDLE

INX ZM

7 mm

PH2

260212

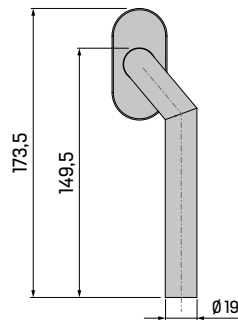
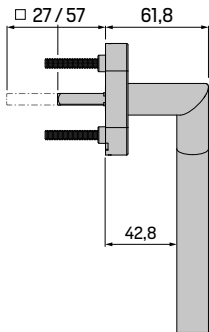

**260211**  
KAIROX RR

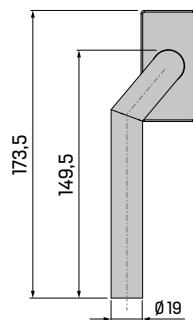
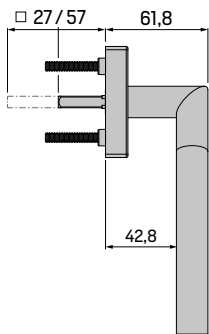

**260312**  
KAIROX CR

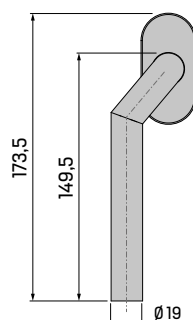
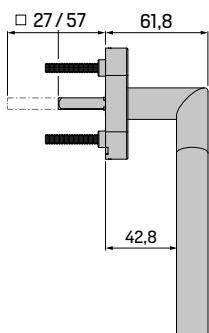

**260212**  
KAIROX RR

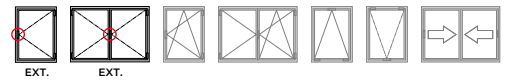

**CREMONA HYDRA CON PALA CORTA**  
HYDRA CREMONE WITH SHORT LEVER

A0740 \*\*

15



Cremona reversible diseñada para ventanas de apertura exterior.

- Dispone de un sistema de cierre compuesto por la propia cremone, un bulón y una pieza que actúa como soporte y transmisión (no incluidos).
- La base de la cremone se fija al perfil por medio de cuatro tornillos autotaladrantes o de rosca métrica (usando remaches roscados).
- Las cremonas se suministran con escudo que reduce notablemente los tiempos de instalación y permite ocultar los tornillos de fijación.

Reversible window cremone designed for outward opening.

- It has a closing system composed of the cremone itself, a bolt and a piece that acts as a support and transmission (not included).
- The base of the cremone is fixed to the profile by means of four self-tapping screws or metric thread (using threaded rivets).
- The cremone is supplied with a shield which significantly reduces installation times and allows the fixing screws to be concealed.

**CREMONA HYDRA CON PALA LARGA**  
HYDRA CREMONE WITH LONG LEVER

A0750L \*\*

15

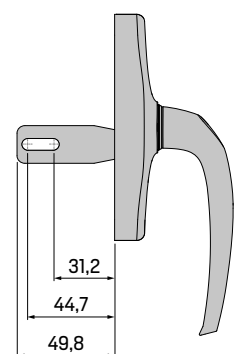
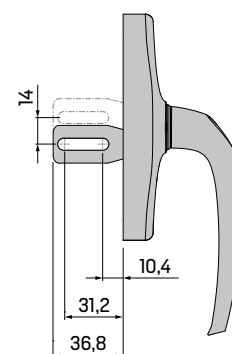
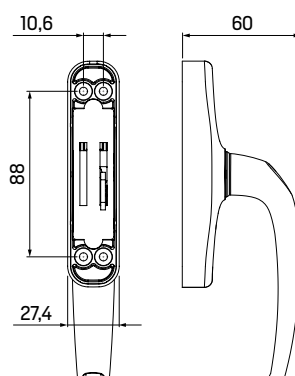
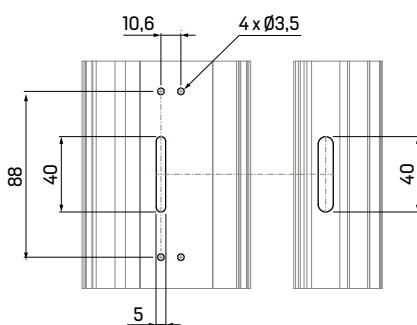
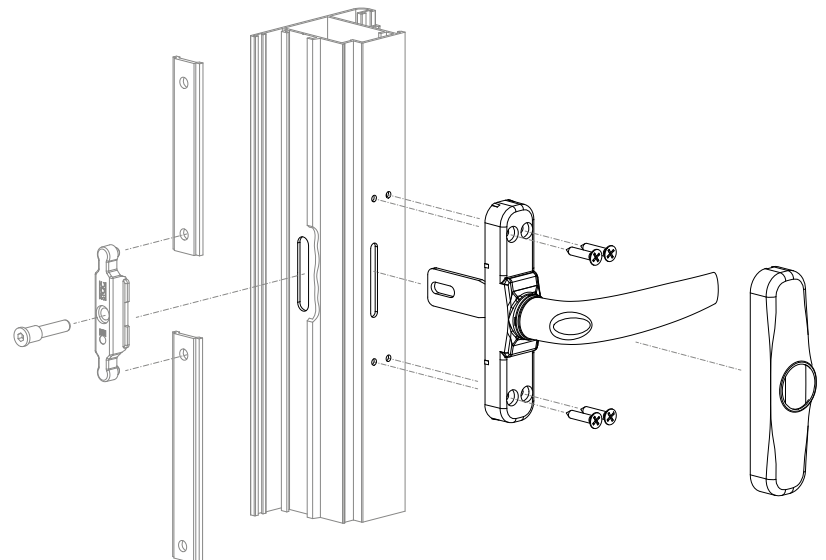

A0740 \*\*

A0750L \*\*

A0790	F	**
-------	---	----

Posibilidad de pedir el producto con el sistema fijación rápida **FAST** incorporado. Para pedir referencias con sistema FAST debe añadirse una « F » antes del acabado (únicamente en aquellos productos en los que esté indicada esta posibilidad).

Possibility of ordering the product with the incorporated **FAST** quick-fixing system. To order references with the FAST system, you must add an "F" before the product finish (only for those products where this possibility is indicated).

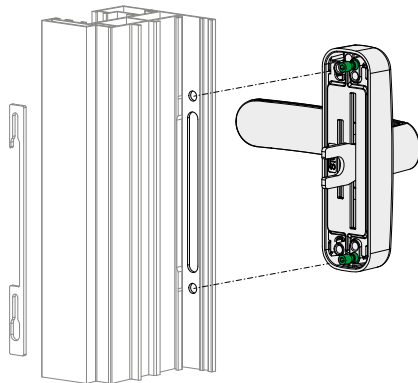

**1**

Colocación de la cremona sobre el perfil haciendo coincidir los tornillos especiales con los mecanizados, de manera que la ranura de los tornillos permanezca a una altura suficiente sobre la base de la cremona, siendo así adaptable a los diferentes espesores de hoja.

Fitting of the cremone over the profile ensuring that the special screws coincide with the prior fabrication in such a way that the screw groove remains at a sufficient height over the base of the cremone will adapt to various sash thicknesses.

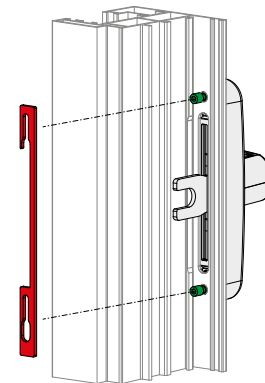

**2**

Cuando la cremona está colocada en el alojamiento mecanizado a tal efecto, se procede a situar la contraplaca sobre los tornillos que sobresalen del plano de la hoja.

When the cremone is fitted in the machined space, the counterplate is situated over the screws that jut out from the profile plane.

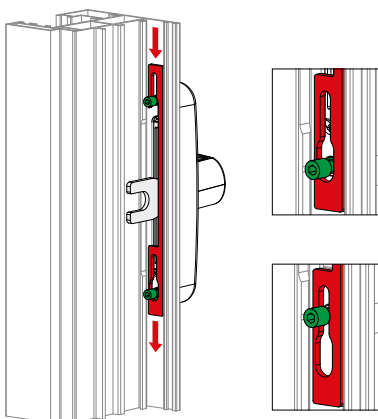

**3**

Una vez colocada, la contraplaca se desliza hacia abajo para situar los tornillos sobre la ranura estrecha de la misma.

Once fitted, the counterplate slides under in order to situate the screws over the narrow groove.

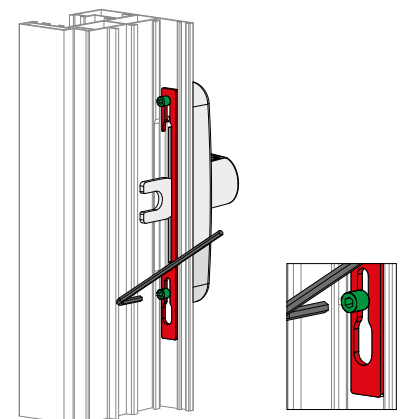

**4**

Tras situarlos de esta forma solo queda fijar los tornillos directamente sobre la contraplaca eliminando cualquier holgura que pueda existir en el conjunto.

Once situated in this way all that is needed is to fix the screws directly over the counterplate, eliminating any play that could exist in the set.

## KITS DE FIJACIÓN PARA MANILLA SIRIUS

FIXING KITS FOR SIRIUS HANDLE

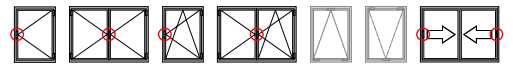

### KITS DE FIJACIÓN PARA DOBLE MANILLA

FIXING KITS FOR DOUBLE HANDLE

**K0771-01**  $D \leq 65 \text{ mm}$  **AC INX**

**K0771-02**  $D \leq 85 \text{ mm}$  **PA**



Kits de fijación para manilla SIRIUS.

- Kits de fijación para la instalación de doble manilla y apertura exterior.

#### Kits para doble manilla

- La fijación se realiza a través de tornillos de seguridad que impiden el acceso desde el exterior de la ventana.
- Los kits permiten su instalación en perfiles de espesor de hasta 65 o 85 mm.

#### Kit para apertura exterior

- Permite realizar instalaciones de apertura exterior en perfiles de ventana de hasta 90 mm.

Fixing kits for SIRIUS handle.

- Fixing kits for double handle installation and outward opening.

#### Double handle kits

- The fixing is carried out by means of security screws that prevent access from the outside of the window.
- The kits allow installation on profiles up to 65 or 85 mm thick.

#### Outward opening kit

- It allows outward opening installations on window profiles up to 90 mm.

### KIT DE FIJACIÓN PARA APERTURA EXTERIOR

OUTWARD OPENING FIXING KIT

**K0775-02**  $D \leq 90 \text{ mm}$  **AC INX**

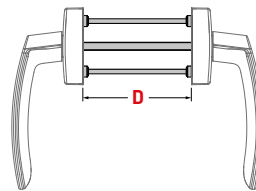

#### » KITS DE FIJACIÓN FIXING KITS **K0771**

**K0771-01**  $D \leq 65 \text{ mm}$

**K0771-02**  $D \leq 85 \text{ mm}$

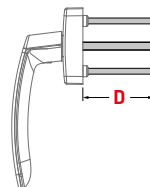
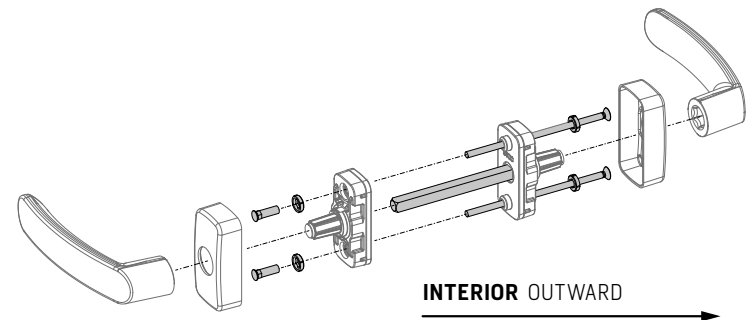

#### » KITS DE FIJACIÓN FIXING KITS **K0775**

**K0775-02**  $D \leq 90 \text{ mm}$

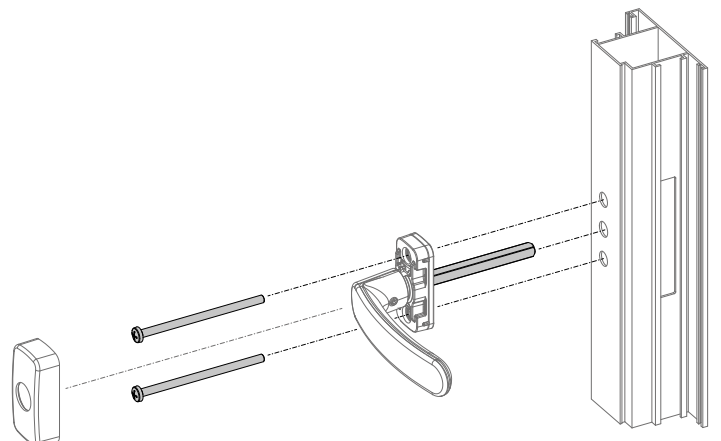

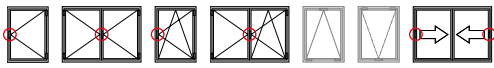

Fixing kits for SIRIUS handle.

- The kits allow the standard fixing systems of the handles to be changed.

**K0771-03 kit**

- The handles are fixed to the profile by means of rivet nuts.

**K0771-04 kit**

- The handles are fixed to the profile by means of self-tapping screws.

Kits de fijación para manilla SIRIUS.

- Los kits permiten cambiar los sistemas de fijación estándar de las manillas.

**Kit K0771-03**

- La fijación de las manillas se realiza por medio de tuercas remachables.

**Kit K0771-04**

- La fijación de las manillas se realiza por medio de tornillos roscachapa.

**KIT DE FIJACIÓN CON TUERCAS REMACHABLES**

FIXING KIT WITH RIVET NUTS

ZM INX

K0771-03

50



**KIT DE FIJACIÓN CON TORNILLOS ROSCACHAPA**

FIXING KIT WITH SELF-TAPPING SCREWS

ZM INX

K0771-04

200



» KITS DE FIJACIÓN FIXING KITS **K0771**

K0771-03

Tuercas remachables Rivet nuts

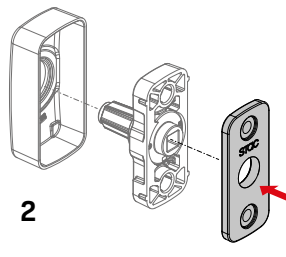
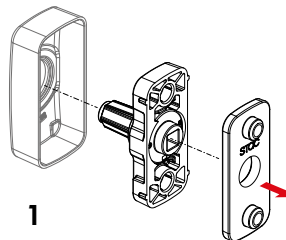
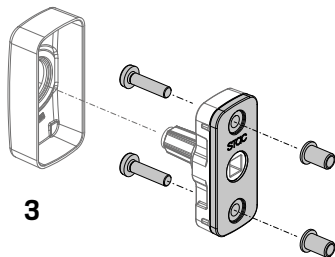

» KITS DE FIJACIÓN FIXING KITS **K0771**

K0771-04

Tornillos roscachapa Self-tapping screws

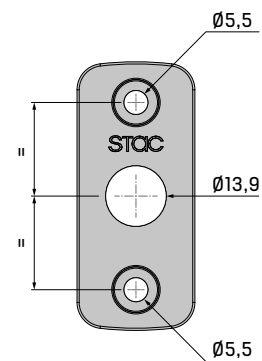
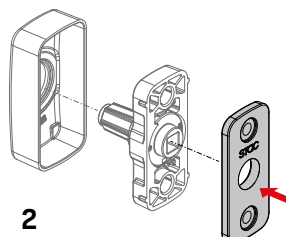
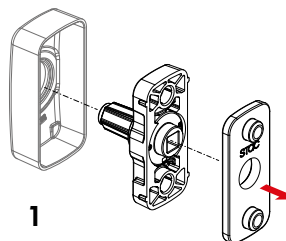
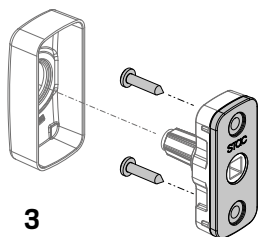

## KITS DE FIJACIÓN PARA MANILLA POLARIS

FIXING KITS FOR POLARIS HANDLE

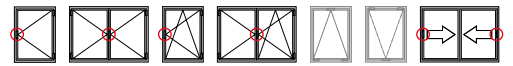

### KITS DE FIJACIÓN PARA DOBLE MANILLA

FIXING KITS FOR DOUBLE HANDLE

K5771-01

$D \leq 55 \text{ mm}$

AC INX

K5771-02

$D \leq 90 \text{ mm}$

50



Kits de fijación para manilla POLARIS.

- Kits de fijación para la instalación de doble manilla y apertura exterior.

#### Kits para doble manilla

- La fijación se realiza a través de tornillos de seguridad que impiden el acceso desde el exterior de la ventana.
- Los kits permiten su instalación en perfiles de espesor de hasta 55 o 90 mm.

#### Kits para apertura exterior

- Los kits permiten realizar instalaciones de apertura exterior en perfiles de ventana de hasta 90 o 100 mm.

Fixing kits for POLARIS handle.

- Fixing kits for double handle installation and outward opening.

#### Double handle kits

- The fixing is carried out by means of security screws that prevent access from the outside of the window.
- The kits allow installation on profiles up to 55 or 90 mm thick.

#### Outward opening kits

- The kits allow outward opening installations on window profiles up to 90 or 100 mm.

### KITS DE FIJACIÓN PARA APERTURA EXTERIOR

OUTWARD OPENING FIXING KITS

K0775-01

$D \leq 110 \text{ mm}$

AC INX

K0775-03

$D \leq 90 \text{ mm}$

100

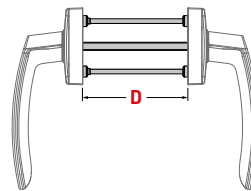

#### » KITS DE FIJACIÓN FIXING KITS K5771

K5771-01  $D \leq 55 \text{ mm}$

K5771-02  $D \leq 90 \text{ mm}$

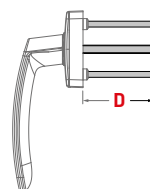
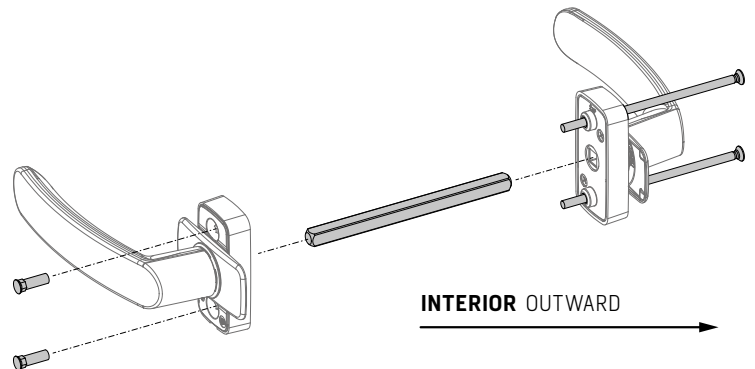

#### » KITS DE FIJACIÓN FIXING KITS K0775

K0775-01  $D \leq 110 \text{ mm}$

K0775-03  $D \leq 90 \text{ mm}$

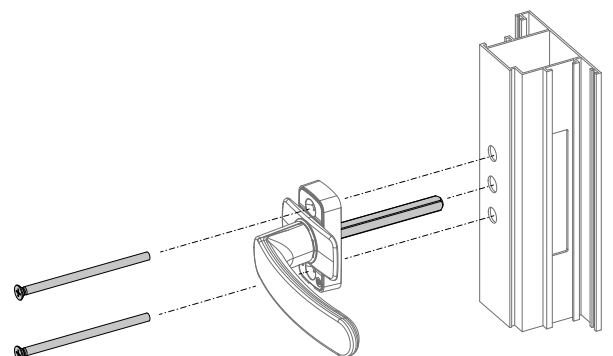



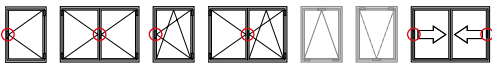

Fixing kits for POLARIS handle.

- The kits allow the standard fixing systems of the handles to be changed.

**K5771-03 kit**

- The handles are fixed to the profile by means of rivet nuts.

**K5771-04 kit**

- The handles are fixed to the profile by means of self-tapping screws.

Kits de fijación para manilla POLARIS.

- Los kits permiten cambiar los sistemas de fijación estándar de las manillas.

**Kit K5771-03**

- La fijación de las manillas se realiza por medio de tuercas remachables.

**Kit K5771-04**

- La fijación de las manillas se realiza por medio de tornillos roscachapa.

**KIT DE FIJACIÓN CON TUERCAS REMACHABLES**  
FIXING KIT WITH RIVET NUTS

ZM INX

K5771-03



**KIT DE FIJACIÓN CON TORNILLOS ROSCACHAPA**  
FIXING KIT WITH SELF-TAPPING SCREWS

ZM INX

K5771-04



» KITS DE FIJACIÓN FIXING KITS **K5771**

K5771-03

Tuercas remachables Rivet nuts

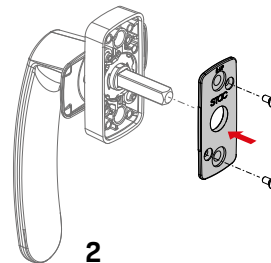
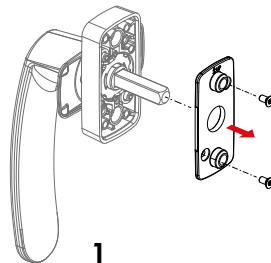
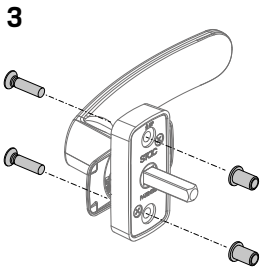

» KITS DE FIJACIÓN FIXING KITS **K5771**

K5771-04

Tornillos roscachapa Self-tapping screws

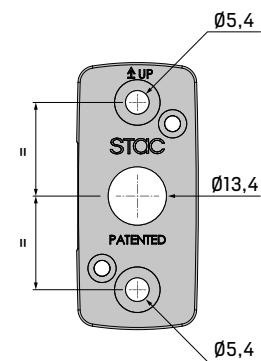
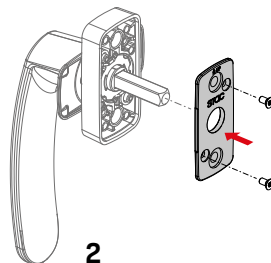
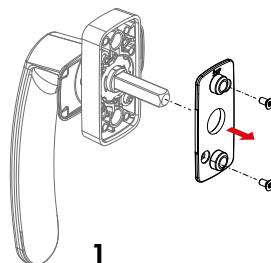
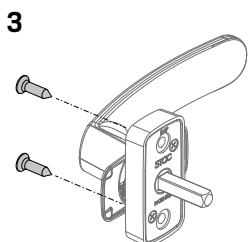



**CAMBIO DE APERTURA OSCIOBATIENTE A PRACTICABLE DE LAS CREMONAS**  
CHANGE FROM TILT & TURN TO SIDE-HUNG OPENING OF THE CREMONES

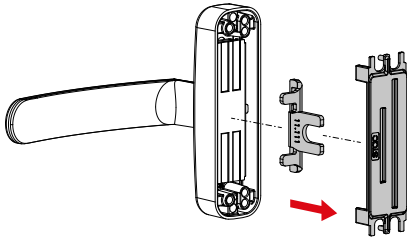

**1**

**Colocamos la cremona en posición de apertura, con la maneta a 90° y retiramos la tapa de plástico y la pala.**

Place the cremone in the opening position, with the handle at 90° and remove the plastic cover and the lever.

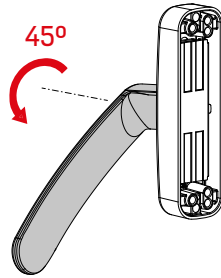

**2**

**Una vez retirada la tapa de plástico y la pala, giramos la maneta 45° como se muestra en el esquema.**

Once the plastic cover and the lever have been removed, turn the handle 45° as shown in the diagram.

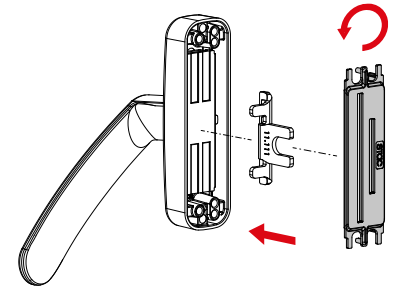

**3**

**Colocamos de nuevo la pala, giramos y montamos la tapa de plástico manteniendo siempre la posición de la maneta a 45°.**

Replace the cremone, turn and install the plastic cover, always keeping the handle position at 45°.



**CAMBIO DE APERTURA DE DERECHAS A IZQUIERDAS DE LA CREMONA PRACTICABLE SIRIUS**  
CHANGE FROM RIGHT TO LEFT-HAND OPENING OF THE SIRIUS SIDE-HUNG CREMONE

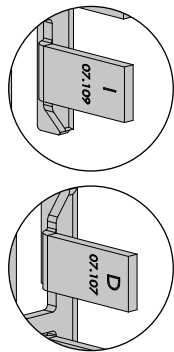

**1**

**Colocamos la cremona en posición de apertura, con la maneta a 90°.**

Place the cremone in the opening position, with the handle at 90°.

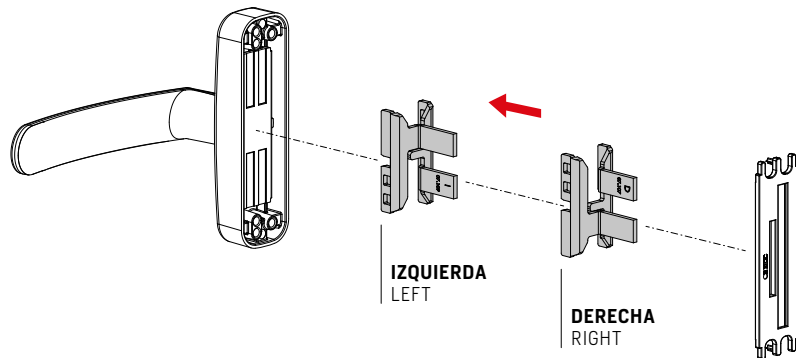

**2**

**Escogemos las palas en función del tipo de apertura (a derechas o a izquierdas).**

Choose the levers according to the type of opening (right or left-handed).

**3**

**Colocamos las palas seleccionadas y posicionamos la tapa de plástico.**

Place the selected levers and replace the plastic cover.

**i La cremona SIRIUS posee dos tipos de palas: en la pala está marcado « D » o « I » para diferenciarlas.**  
The SIRIUS cremone has two types of levers: « D » or « I » is marked on the lever to differentiate between them.

**CAMBIO DE APERTURA DE DERECHAS A IZQUIERDAS DE LA CREMONA PRACTICABLE LEO**  
CHANGE FROM RIGHT TO LEFT-HAND OPENING OF THE LEO SIDE-HUNG CREMONE

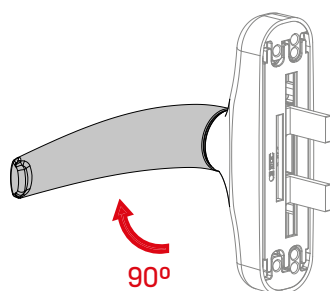

**1**

**Colocamos la cremone en posición de apertura, con la maneta a 90°.**

Place the cremone in opening position, with the handle at 90°.

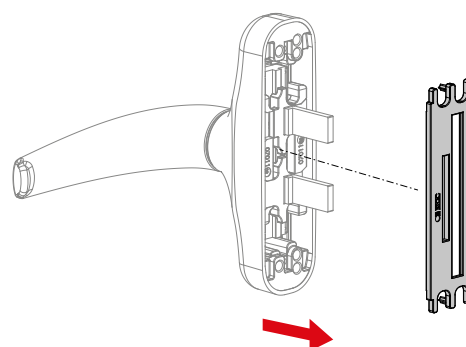

**2**

**Con la maneta a 90°, retiramos la tapa de plástico.**

With the handle at 90°, remove the plastic cover.

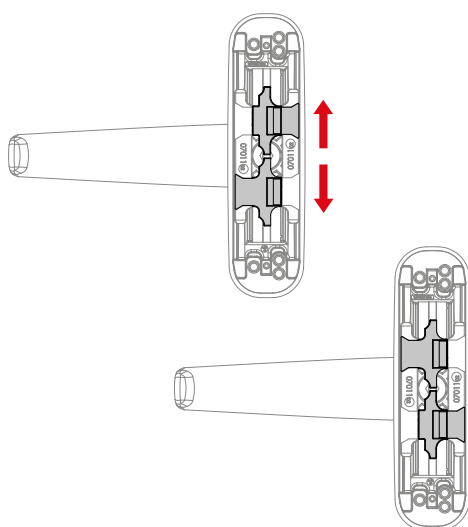

**3**

**Intercambiamos la posición de las palas.**

Interchange the position of the levers.

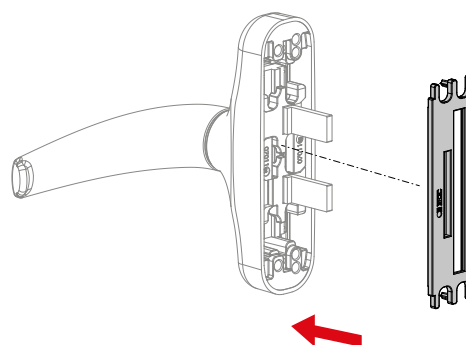

**4**

**Para completar el montaje, colocamos de nuevo la tapa de plástico.**

To complete the assembly, replace the plastic cover.



**CAMBIO DE APERTURA DE DERECHAS A IZQUIERDAS DE LAS CREMONAS OSCILOBATIENTES SIRIUS BLOCK Y LYRA BLOCK**  
CHANGE FROM RIGHT TO LEFT-HAND OPENING OF THE SIRIUS BLOCK AND LYRA BLOCK TILT & TURN CREMONES

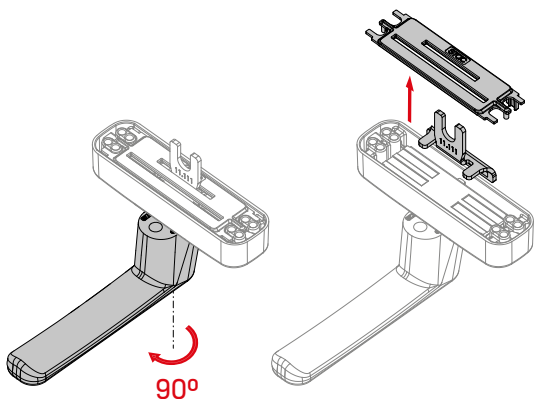

**1**

**Colocamos la cremona en posición de apertura, con la maneta a 90° y retiramos la tapa de plástico y la pala.**

Place the cremone in the opening position, with the handle at 90° and remove the plastic cover and the lever.

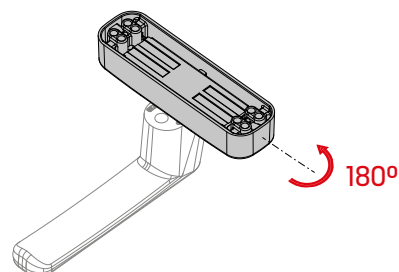

**2**

**Con la maneta a 90°, giramos todo el escudo 180°.**

With the handle at 90°, we turn the entire scutcheon 180°.

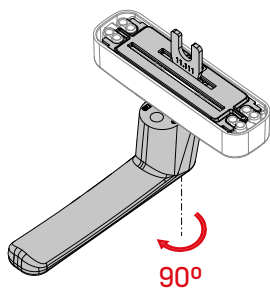

**3**

**Para completar el montaje, colocamos la pala, la tapa de plástico y giramos la maneta 90°.**

To complete the assembly, place the lever, the plastic cover and turn the handle 90°.

**CAMBIO DE APERTURA OSCIOBATIENTE A PROYECTANTE DE LAS CREMONAS**  
CHANGE FROM TILT & TURN TO TOP-HUNG OPENING OF THE CREMONES

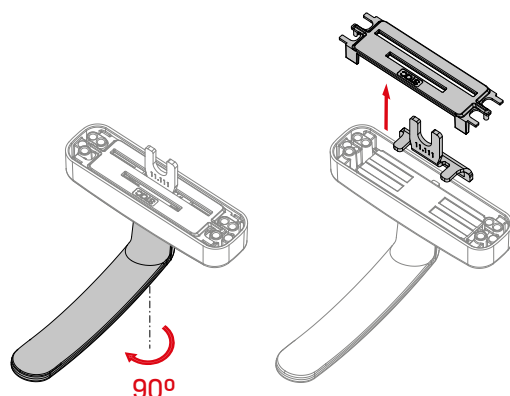

1

**Colocamos la cremona en posición de apertura, con la maneta a 90° y retiramos la tapa de plástico y la pala.**

Place the cremone in the opening position, with the handle at 90° and remove the plastic cover and the lever.

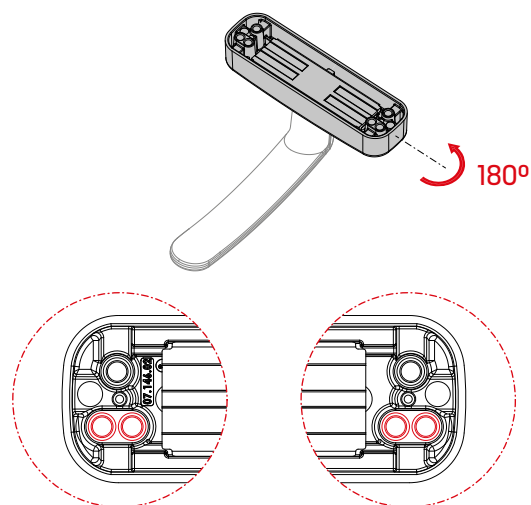

2

**Giramos todo el escudo de la cremona 180°. El doble taladro debe quedar orientado hacia abajo. En la cremona SIRIUS BLOCK el resalte indicado debe quedar orientado a la derecha.**

Turn the entire cremone scutcheon 180°. The double bore must face downwards. On the SIRIUS BLOCK cremone, the indicated protrusion must be oriented to the right.

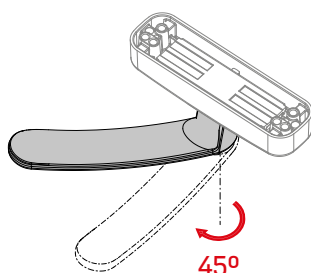

3

**Giramos la maneta 45°.**

Turn the handle 45°.

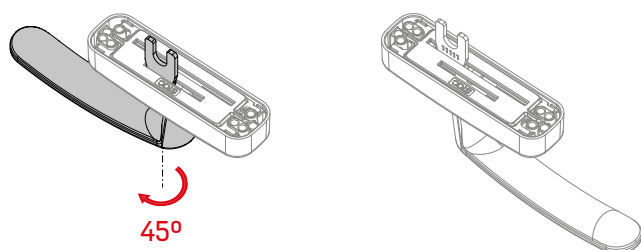

**PALA EN POS. PROYECTANTE**  
LEVER IN TOP-HUNG POSITION

**PALA EN POS. OSCILO**  
LEVER IN TILT POSITION

5

**Para completar el montaje, giramos la maneta 45°.**

To complete the assembly, turn the handle 45°.

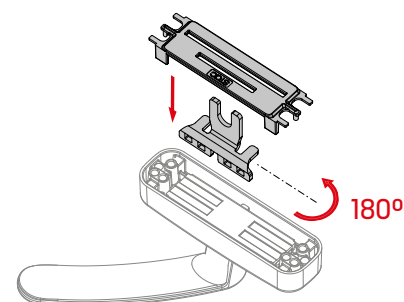

4

**Manteniendo la maneta en la posición anterior (225°), giramos la pala 180° colocando el centro hacia el lado de los taladros dobles y colocamos la tapa de plástico.**

Keeping the handle in the previous position (225°), turn the lever 180° with the centre towards the side of the double bore and place the plastic cover.



**POSICIONES DEL PULSADOR DE BOMBILLO DE LA CREMONA CON LLAVE SIRIUS BLOCK**  
BARREL PUSH BUTTON POSITIONS FOR THE SIRIUS BLOCK CREMONE WITH KEY

**POSICIONES ESTÁNDAR DEL PULSADOR** STANDARD PUSH BUTTON POSITIONS



**POSICIÓN POSITION 1**    **POSICIÓN POSITION 2**    **POSICIÓN POSITION 3**

► **CAMBIO DE POSICIÓN** CHANGE POSITION **1 > 2**

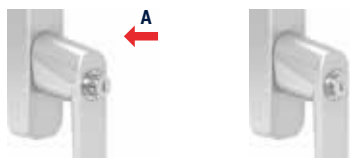

**PULSAR LIGERAMENTE «A»**

LIGHTLY PRESS «A»

► **CAMBIO DE POSICIÓN** CHANGE POSITION **2 > 1**



**INTRODUCIR LA LLAVE «A» Y GIRAR 45° A LA IZQUIERDA «B»**

INSERT THE KEY «A» AND TURN 45° TO THE LEFT «B»

► **CAMBIO DE POSICIÓN** CHANGE POSITION **2 > 3**

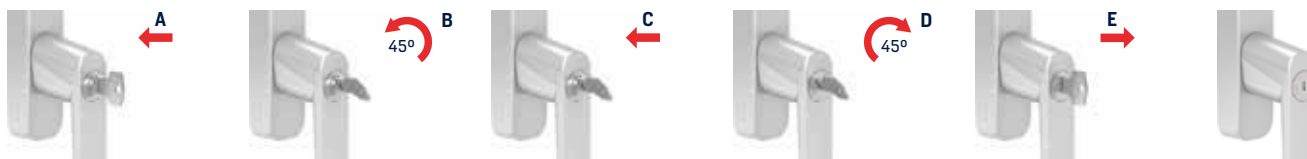

**INTRODUCIR LA LLAVE «A», GIRAR 45° A LA IZQUIERDA «B» Y PRESIONAR CON LA LLAVE GIRADA «C». MANTENIENDO LA PRESIÓN VOLVEMOS A GIRAR LA LLAVE EN SENTIDO INVERSO «D» Y RETIRAMOS LA LLAVE «E».**

INSERT THE KEY «A», TURN 45° TO THE LEFT «B» AND PRESS WITH THE KEY TURNED «C». KEEPING THE PRESSURE ON, TURN THE KEY BACK THE OTHER WAY ROUND «D» AND REMOVE THE KEY «E».

POSICIONES DE MANIOBRA LÓGICA DE LA CREMONA OSCIOBATIENTE SIRIUS BLOCK  
TILT-BEFORE-TURN POSITIONS OF THE SIRIUS BLOCK TILT & TURN CREMONE



La cremona oscilobatiente SIRIUS BLOCK con cierre de seguridad posee un bombillo de cerradura con pulsador que permite bloquear el movimiento en las diferentes posiciones para la apertura. The SIRIUS BLOCK tilt & turn cremone with security lock has a lock barrel with a push button that allows the movement to be blocked in the different opening positions.

**BLOQUEO TOTAL** TOTAL BLOCK

La maneta de la cremona se acciona y desbloquea con la llave y no permite el movimiento.

The handle of the cremone is activated and unlocked with the key and does not allow movement.

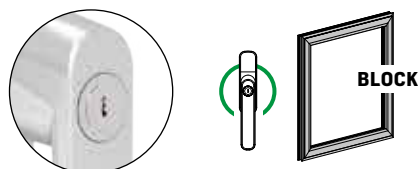

**2 BLOQUEO INTERMEDIO** INTERMEDIATE BLOCK

La maneta de la cremona se acciona pulsando y se desbloquea con la llave. La maneta permite girar solamente 90°.

The handle of the cremone is operated by pressing and unlocked with the key. The handle can only be rotated by 90°.

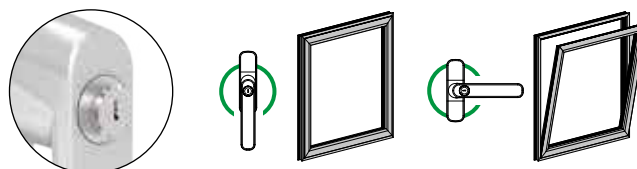

**3 DESBLOQUEO** UNBLOCKING

La maneta de la cremona está totalmente desbloqueada y puede ponerse en cualquier posición.

The handle of the cremone is fully unlocked and can be set to any position.

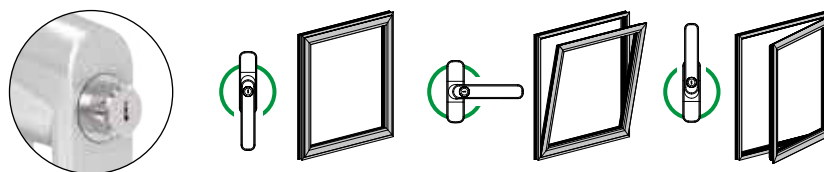

POSICIONES DE MANIOBRA LÓGICA DE LA CREMONA OSCIOBATIENTE LYRA BLOCK  
TILT-BEFORE-TURN POSITIONS OF THE LYRA BLOCK TILT & TURN CREMONE

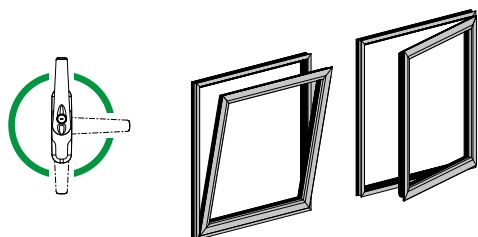

■ LLAVE KEY 0°

LA VENTANA PUEDE OSCILAR Y ABRIR  
THE WINDOW CAN TILT AND OPEN

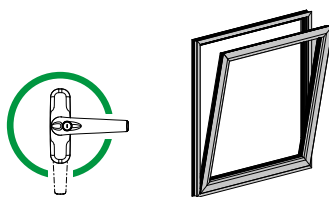

■ LLAVE KEY 90°

LA VENTANA SOLO PERMITE OSCILAR  
THE WINDOW ONLY ALLOWS TILT

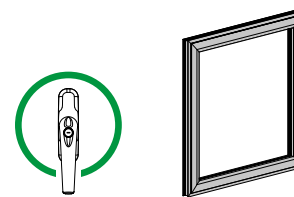

■ LLAVE KEY 180°

LA VENTANA NO PERMITE NI OSCILAR NI ABRIR  
THE WINDOW CAN NEITHER TILT NOR OPEN







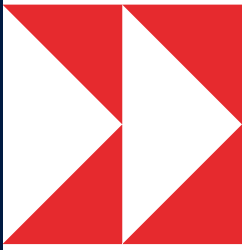

# 03

## MANILLAS DE PUERTA DOOR HANDLES

- 108 **Manillas MINIMALISTAS**  
MINIMALIST handles
- 110 **Manillas POLARIS**  
POLARIS handles
- 112 **Manillas SIRIUS**  
SIRIUS handles
- 113 **Manillas GÉMINIS**  
GEMINIS handles
- 114 **Manillas LIBRA**  
LIBRA handles
- 115 **Manillas INDO**  
INDO handles
- 116 **Manillas KAIROX**  
KAIROX handles
- 118 **Tiradores TAU**  
TAU pull handles
- 122 **Tiradores NAOS**  
NAOS pull handles
- 123 **Tiradores FÉNIX**  
FENIX pull handles
- 124 **Embellecedores de cilindro**  
Cylinder cover plates
- 126 **Notas técnicas**  
Technical notes





# MANILLAS MINIMALISTAS

## MINIMALIST HANDLES



**Mecanismo oculto**  
Concealed mechanism



**Máxima durabilidad**  
Highest durability



**Gama completa de acabados**  
Full range of finishes



**Robustez contrastada**  
Tested robustness

Para las personas que anhelan la sensación de creatividad, calidad y estilo en sus espacios, STAC introduce la línea minimalista de manillas para ventana y puerta con el fin de ofrecer una gama completa de soluciones técnicas de la más alta calidad.

En el planteamiento se ha prescindido de todos los elementos innecesarios, desarrollando un mecanismo oculto que sólo deja expuesta la manilla dando como resultado una familia de manillas que garantizan una gran fiabilidad y robustez a lo largo de todo su vida útil.

### » Línea completa

La línea de manillas minimalistas es válida para diferentes tipos de apertura existentes en el mercado.

- Puerta
- Ventana
- Multipunto
- Aluminio de canal 16 mm

### » Gama completa de acabados

Cada vez son más los proyectos que buscan su singularidad a través de colores o acabados y en donde los accesorios se lacan en los mismos colores que los sistemas de carpintería. La línea minimalista está disponible tanto en lacado blanco o negro como en los colores que conforman la carta RAL, un sistema de combinación de tonalidades que define colores para pinturas, plásticos y recubrimientos.

For those people who wish to have a sensation of creativity, quality and style, STAC is pleased to present their minimalist range of handles for windows and doors, a complete range of the highest quality technical solutions.

The design of these handles does away with all unnecessary elements and we have developed a hidden mechanism so the only part on display is the handle itself. The result is a family of handles with guaranteed reliability and strength throughout their lifecycle.

### » Complete range

The line of minimalist handles is suitable for different types of openings available on the market.

- Door
- Window
- Multipoint systems
- Aluminium systems with 16 mm groove

### » Full range of finishes

There are ever more projects which try to stand out through their used of colour and finishes; the hardware can be painted in the same colour as the aluminium carpentry. The minimalist range is available in both black and white lacquer and the colours that make up the RAL chart, a colour matching system that defines colours for paints, plastics and coatings.

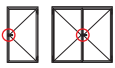

Minimalist handles with recoverable mechanism for doors.

- Minimalist handles with concealed mechanism without cover.
- The minimalist handles are supplied with an 8 x 100 mm spindle.
- The handles have an opening hand.
- They stand out for their robustness and ease of use in opening and closing.
- The handles are available in a variety of finishes.

See compatible cylinder covers with the handle on page 124.

Manillas minimalistas con mecanismo recuperable para puertas.

- Manillas minimalistas con mecanismo oculto sin escudo embellecedor.
- Las manillas se suministran con un cuadrado de 8 x 100 mm.
- Las manillas tienen mano de apertura.
- Destacan por su robustez y comodidad de uso en la apertura y cierre.
- Las manillas están disponibles en una gran variedad de acabados.

Ver embellecedores de cilindro compatibles con la manilla en la página 124.

**MINIMALISTA DELTA**  
DELTA MINIMALIST

**	JUEGO DE MANILLAS HANDLE SET	7771	**
AL ZM		7781	**
INX		7791	**
8 mm			

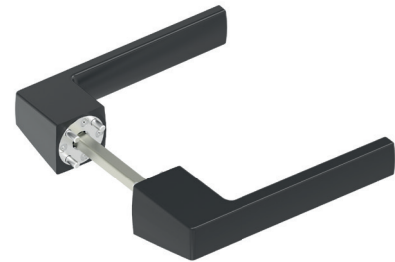

**MINIMALISTA GAMMA**  
GAMMA MINIMALIST

**	JUEGO DE MANILLAS HANDLE SET	7773	**
AL ZM		7783	**
INX		7793	**
8 mm			

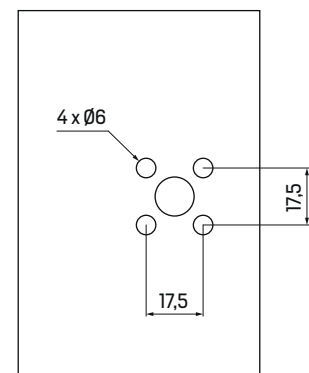
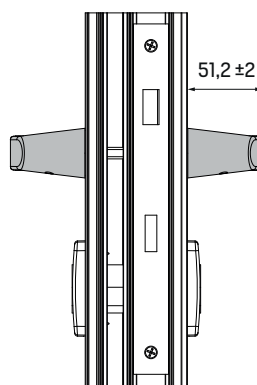
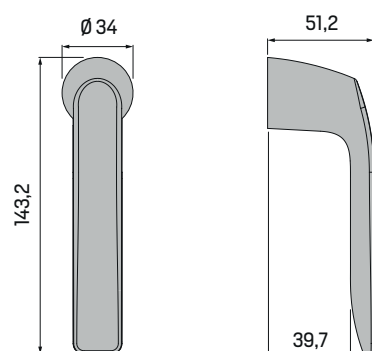
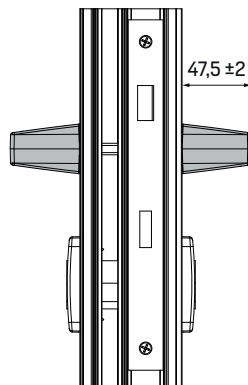
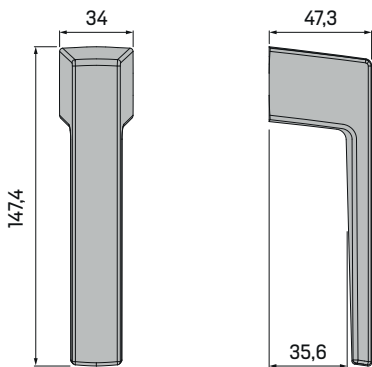
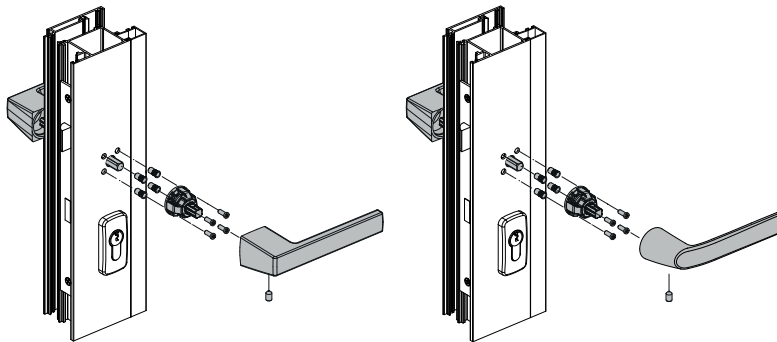



# POLARIS

La manilla de puerta **más resistente** del mercado  
The most resistant door handle on the market

**+75%**

**Resistencia según UNE**  
Resistance according to UNE



**Manillas ambidiestras**  
Ambidextrous handles



**Instalación rápida**  
Quick installation



**Robustez contrastada**  
Tested robustness

Línea de manillas de altas prestaciones concebida para un uso intensivo en edificaciones con alta frecuencia de paso o de grandes dimensiones como son las puertas públicas con cierrapuertas, donde la manilla tiene que soportar constantemente todo tipo de esfuerzos y golpes. El avanzado diseño de la manillas POLARIS permite su montaje con gran simplicidad en toda clase de perfiles con espesores de aluminio muy diferentes. La ausencia de mano y la triple posibilidad de fijación al perfil, la convierten en la manilla idónea para su instalación en puertas alta frecuencia de utilización por el público.

## » Mecanismo POLARIS

Mecanismo base de transmisión que destaca por sus componentes metálicos que proporcionan una alta resistencia y durabilidad a ciclos, certificadas a través de múltiples ensayos tanto internos como externos. Entre sus características resalta su escudo giratorio integrado que permite una reducción notable en los tiempos de instalación de la manilla.

## » Maneta SLIM

La maneta SLIM se posiciona principalmente como solución ideal para instalaciones en puertas balconeras o correderas en donde la persiana no habilita el espacio necesario para el montaje de una manilla o cremone tradicional, aunque su versatilidad permite el uso convencional como maneta estándar en cualquier tipo de apertura existente en el mercado del cerramiento.

## » UNE-EN 1906: 2015

Las manillas han sido testadas según normativa UNE-EN 1906 obteniendo una clasificación de grado 2 en categoría de uso: aptas para su uso en puertas de alta frecuencia de utilización por el público o por personas poco cuidadosas, y, donde hay grandes riesgos de mala utilización; por ejemplo, puertas de oficinas públicas.

High performance handle range which was conceived taking in to consideration intensive use in buildings with a high frequency of passage or of large dimensions such as public use doors with door closers where the handle has to constantly withstand all types of knocks and handling. The advanced design of the POLARIS handles allows for very simple assembly on to all types of profiles with very different aluminium thicknesses. It is ambidextrous and along with the three different profile fixing systems makes this handle ideal for installation on to doors for high pedestrian traffic use.

## » POLARIS mechanism

Base transmission mechanism that stands out primarily for its metal components which provide high cycle strength and durability, certified through multiple internal and external tests. Its features include an integrated rotary cover ring that allows for a noticeable reduction in handle installation times.

## » SLIM handle

The SLIM handle is envisaged as the ideal solution for installations of balcony doors or sliding doors where the shutters do not leave the space necessary for the mounting of a traditional cremone or handle. Further, its versatility allows for conventional use as a standard handle in any type of opening existing in the door and window market.

## » UNE-EN 1906: 2015

The handles have been tested in accordance with UNE-EN 1906 obtaining a grade 2 classification in category of use: suitable for use in doors of high frequency of use by the public or by non-careful persons, and, where there are great risks of misuse; for example, doors to public offices.

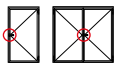

Handle with recoverable mechanism for doors with high frequency of passage.

- The POLARIS SLIM handle is envisaged as the ideal solution for installations of doors where the shutters do not leave the space necessary for the mounting of a traditional handle.
- The handles are ambidextrous and they are supplied with a zinc-plated steel spindle of 8 x 129 mm.
- Tested in accordance with European standard UNE-EN 1906:2015 to grade 2 with satisfactory results.
- Different types of fixation to the profile are available: self-tapping screws, rivet nuts or security screws.

See compatible cylinder covers with the handle on page 124.

Manilla con mecanismo recuperable para puertas con alta frecuencia de paso.

- La manilla POLARIS SLIM es la solución ideal para instalaciones en puertas en donde la persiana no habilita el espacio necesario para el montaje de una manilla tradicional.
- Las manillas son ambidiestras y se suministran con cuadrado en acero zincado de 8 x 129 mm.
- Testadas de acuerdo a la normativa europea UNE-EN 1906:2015 a grado 2 con resultado satisfactorio.
- Disponibles diferentes tipos de fijación al perfil: tornillos roscachapa, tuercas remachables o tornillos de seguridad.

Ver embellecedores de cilindro compatibles con la manilla en la página 124.

**MANILLA POLARIS**  
POLARIS HANDLE



JUEGO DE MANILLAS  
HANDLE SET **05182** \*\*

MANILLA SIMPLE  
SIMPLE HANDLE **05183** \*\*



**05182 05183**

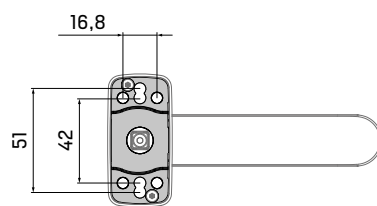
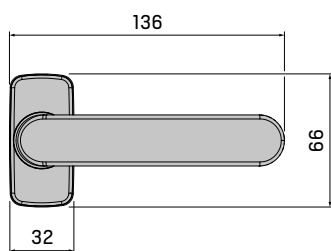
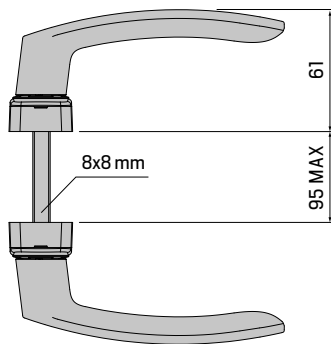

**05182S 05183S**

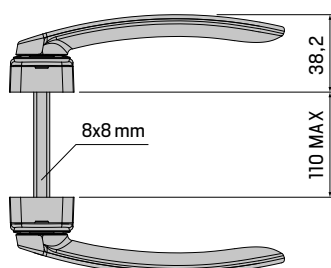

**MANILLA POLARIS SLIM**  
POLARIS SLIM HANDLE



JUEGO DE MANILLAS  
HANDLE SET **05182S** \*\*

MANILLA SIMPLE  
SIMPLE HANDLE **05183S** \*\*



» **KITS DE FIJACIÓN PARA LAS MANILLAS POLARIS** FIXING KITS FOR POLARIS HANDLES

-	<b>KIT DE FIJACIÓN TRADICIONAL</b> STANDARD FIXING KIT	<b>Página</b> Page <b>126</b>
KT0518-01	<b>KIT DE FIJACIÓN CON TUERCAS REMACHABLES</b> RIVET NUTS FIXING KIT	<b>Página</b> Page <b>126</b>
KT0518-02	<b>KIT DE FIJACIÓN SECURITY ( D &lt; 60 mm)</b> SECURITY FIXING KIT	<b>Página</b> Page <b>126</b>
KT0518-03	<b>KIT DE FIJACIÓN SECURITY ( 60 &lt; D &lt; 80 mm)</b> SECURITY FIXING KIT	<b>Página</b> Page <b>126</b>

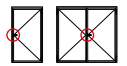

**MANILLA SIRIUS SIMPLE**  
SIRIUS SIMPLE HANDLE

A05083 \*\* 25



\*\*

RAL

AL ZM

INX AC

8 mm

PH2

allen2,5

Manilla de puerta recuperable con mecanismo de transmisión reforzado.

- La manilla mantiene la línea estética de las cremonas y manilla SIRIUS.
- Las manillas son ambidiestras y se suministran con cuadradillo en acero zincado de 8 x 129 mm.
- La base del mecanismo de transmisión permite la fijación de hasta 4 tornillos con doble posicionamiento cada uno.
- La base del mecanismo de transmisión ha sido reforzada a través de su fabricación en zamak, otorgando mayor dureza y resistencia a la base.
- Ver embellecedores de cilindro compatibles con la manilla en la página 124.

Recoverable door handle with reinforced transmission mechanism.

- The handle keeps the aesthetic line of the SIRIUS cremone and handle.
- The handles are ambidextrous and they are supplied with a zinc-plated steel spindle of 8 x 129 mm.
- The base of the handle transmission mechanism allows the fixing of up to 4 screws with double positioning each.
- The base of the transmission mechanism has been reinforced through its manufacture in zamak, providing greater hardness and resistance to the base.

See compatible cylinder covers with the handle on page 124.

**JUEGO DE MANILLAS SIRIUS**  
SIRIUS HANDLE SET

A05082 \*\* 20



\*\*

RAL

AL ZM

INX AC

8 mm

PH2

allen2,5

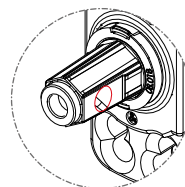
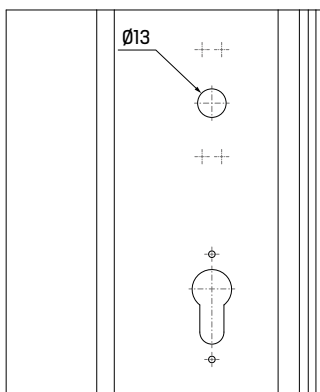
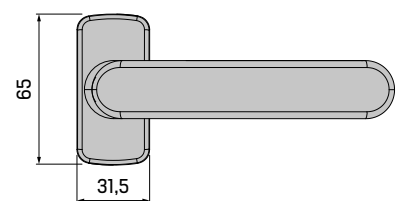
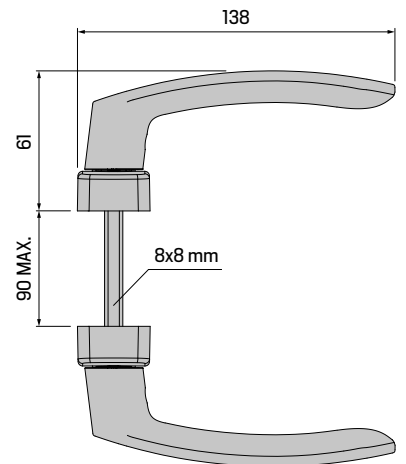

POSICIONAR EL AGUJERO HACIA LA HOJA  
POSITION THE HOLE TOWARDS THE SASH

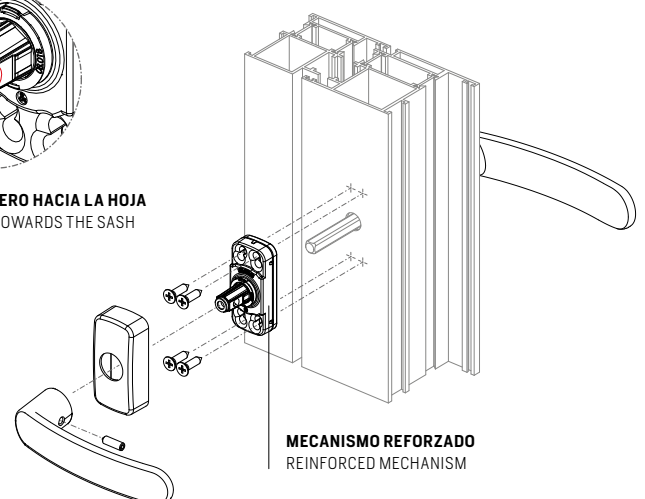
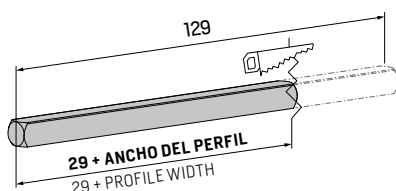

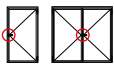

Handle with recoverable mechanism for doors.

- The handle keeps the aesthetic line of the LYRA and LEO cremones.
- The handles are ambidextrous and they are supplied with a zinc-plated steel spindle of 8 x 129 mm.
- The base of the handle transmission mechanism allows the fixing of up to 4 screws with double positioning each.
- The design of the covers that cover the screws hides the whole mechanism of fixing the handle, increasing the aesthetics and contributing to a practical and fast installation.

Manilla con mecanismo recuperable para puertas.

- La manilla mantiene la línea estética de las cremonas LYRA y LEO.
- Las manillas son ambidiestras y se suministran con cuadradillo en acero zincado de 8 x 129 mm.
- La base del mecanismo de transmisión permite la fijación de hasta 4 tornillos con doble posicionamiento cada uno.
- El diseño de las tapas que cubren los tornillos ocultan todo el mecanismo de fijación de la manilla, aumentando la estética y contribuyendo a una práctica y rápida instalación.

See compatible cylinder covers with the handle on page 124.

Ver embellecedores de cilindro compatibles con la manilla en la página 124.

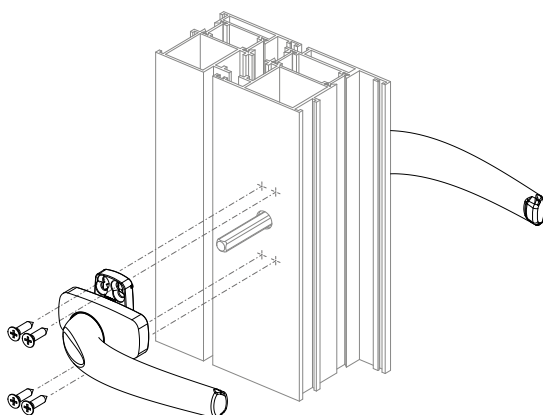
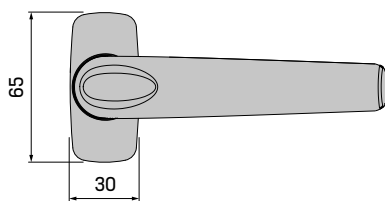
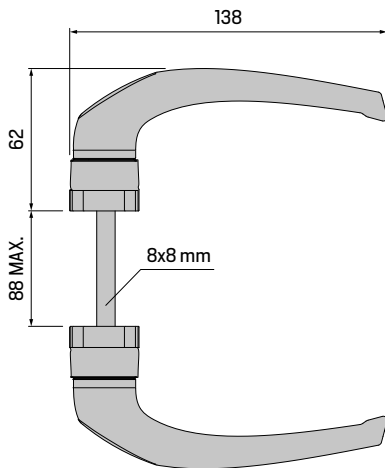

**MANILLA SIMPLE GÉMINIS**  
GEMINIS SIMPLE HANDLE

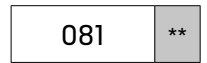

**JUEGO DE MANILLAS GÉMINIS**  
GEMINIS HANDLE SET

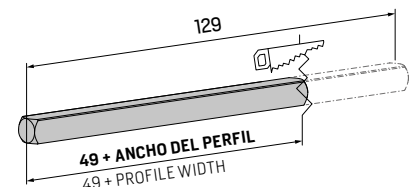
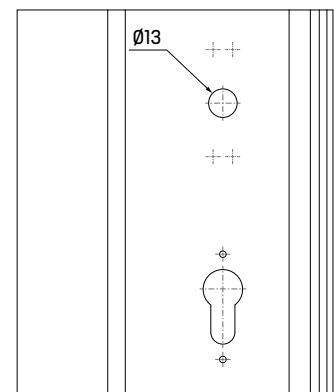
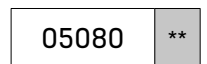

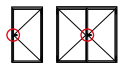

**MANILLA SIMPLE LIBRA**  
LIBRA SIMPLE HANDLE



Manilla compacta con mecanismo recuperable para puertas.

- La manilla compacta LIBRA es la solución ideal para instalaciones en puertas en donde la persiana no habilita el espacio necesario para el montaje de una manilla tradicional.
- La manilla mantiene la línea estética de las cremonas LYRA y manilla GÉMINIS.
- Las manillas son ambidiestras y se suministran con cuadradillo en acero zincado de 8 x 129 mm.
- La base del mecanismo de transmisión permite la fijación de hasta 4 tornillos con doble posicionamiento cada uno.
- El diseño de las tapas que cubren los tornillos ocultan todo el mecanismo de fijación de la manilla.

Compact handle with recoverable mechanism for doors.

- The LIBRA compact handle is envisaged as the ideal solution for installations of doors where the shutters do not leave the space necessary for the mounting of a traditional handle.
- The handle keeps the aesthetic line of the LYRA cremone and GEMINIS handle.
- The handles are ambidextrous and they are supplied with a zinc-plated steel spindle of 8 x 129 mm.
- The base of the handle transmission mechanism allows the fixing of up to 4 screws with double positioning each.
- The design of the covers that cover the screws hides the whole mechanism of fixing the handle.

**JUEGO DE MANILLAS LIBRA**  
LIBRA HANDLE SET

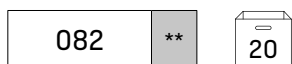

Ver embellecedores de cilindro compatibles con la manilla en la página 124.

See compatible cylinder covers with the handle on page 124.

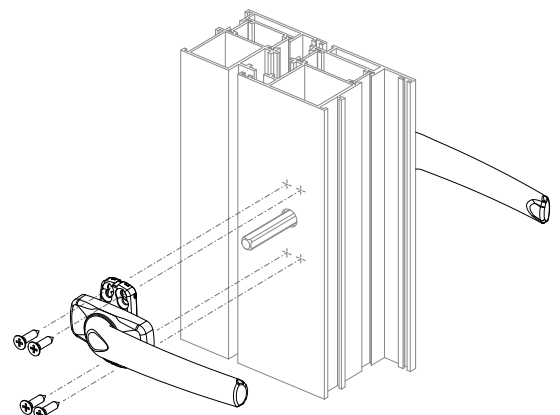
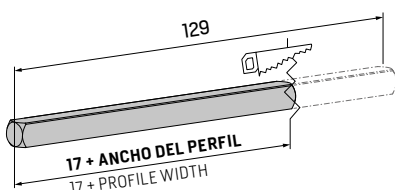
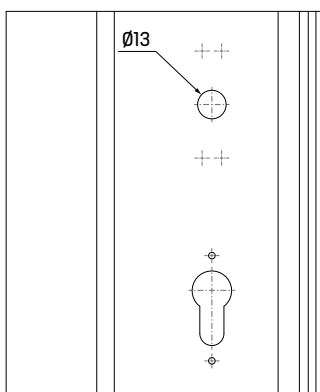
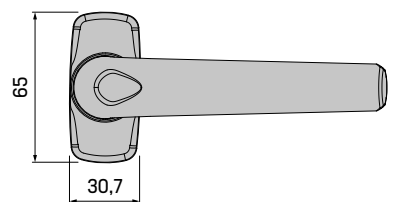
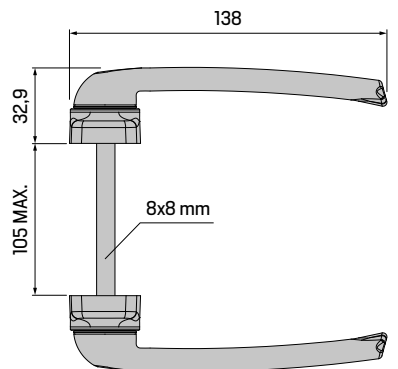



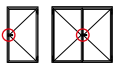

Handle with recoverable mechanism for doors.

- The handle keeps the aesthetic line of the LYRA and LEO cremones.
- The handles are ambidextrous and they are supplied with a zinc-plated steel spindle of 8 x 129 mm.
- The design of the covers that cover the screws hides the whole mechanism of fixing the handle, increasing the aesthetics and contributing to a practical and fast installation.
- Handle tested according to European standard UNE-EN 1906: 2015 to grade 3 with satisfactory result.

See compatible cylinder covers with the handle on page 124.

Manilla con mecanismo recuperable para puertas.

- La manilla mantiene la línea estética de las cremonas LYRA y LEO.
- Las manillas son ambidiestras y se suministran con cuadradillo en acero zincado de 8 x 129 mm.
- El diseño de las tapas que cubren los tornillos ocultan todo el mecanismo de fijación de la manilla, aumentando la estética y contribuyendo a una práctica y rápida instalación.
- Manilla testada de acuerdo a la normativa europea UNE-EN 1906: 2015 a grado 3 con resultado satisfactorio.

Ver embellecedores de cilindro compatibles con la manilla en la página 124.

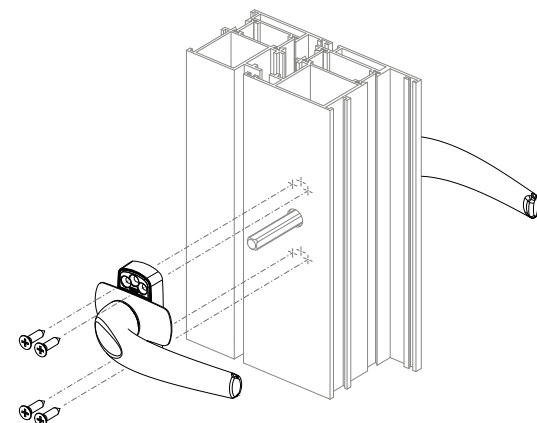
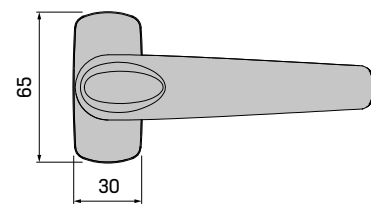
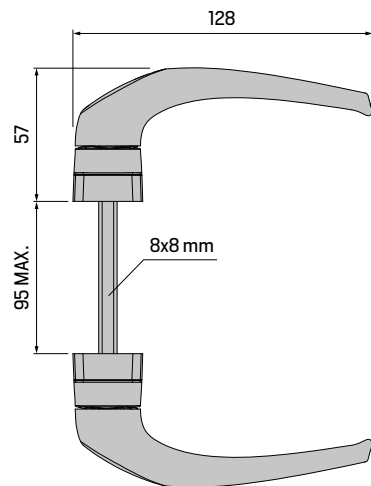

**MANILLA SIMPLE INDO**  
INDO SIMPLE HANDLE

\*\*

RAL

AL ZM

INX AC

8 mm

PH2

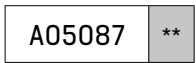

**JUEGO DE MANILLAS INDO**  
INDO HANDLE SET

\*\*

RAL

AL ZM

INX AC

8 mm

PH2

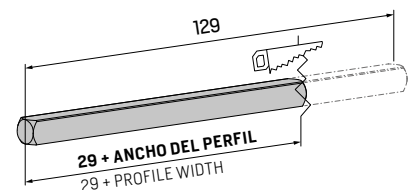
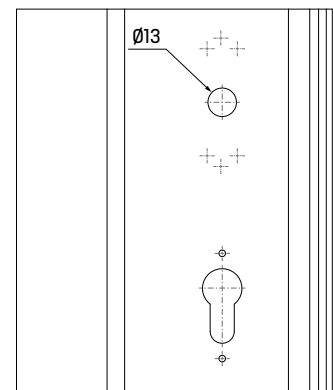
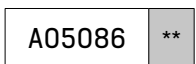

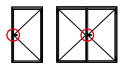

**JUEGO DE MANILLAS KAIROX CC**  
KAIROX CC HANDLE SET

260120 



Manillas de acero inoxidable con mecanismo recuperable para puertas.

- Manilla, roseta y embellecedor de bombillo en acero inoxidable AISI 304.
- La fijación de las manillas se realiza directamente sobre el perfil mediante el uso de tornillos roscachapa.
- Cada referencia se suministra en juegos de manillas con cuadradillo en acero zincado de 8 x 110 mm, embellecedores de bombillo y tornillería.
- Las manillas han sido diseñadas con el mecanismo interno metálico y ajustado y han sido testadas a 200,000 ciclos de apertura con resultado satisfactorio.

Stainless steel handles with recoverable mechanism for doors.

- Handle, rosette and cylinder cover are made of AISI 304 stainless steel.
- The fixing of the handles is made directly on the profile using self-tapping screws.
- Each handle reference is supplied in handle sets with 8 x 110 mm zinc-plated steel spindle, cylinder covers and screws.
- The handles have been designed with the internal metal mechanism and adjusted and have been tested at 200,000 opening cycles with satisfactory results.

**JUEGO DE MANILLAS KAIROX RR**  
KAIROX RR HANDLE SET

260220 

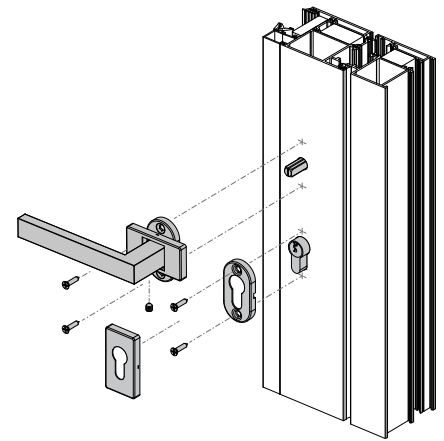
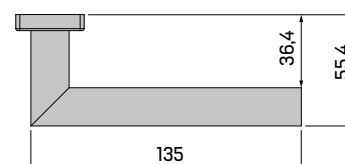
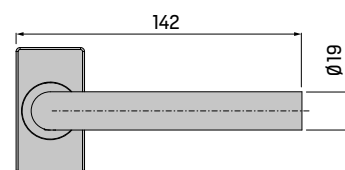
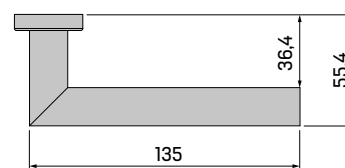
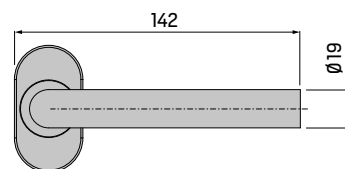
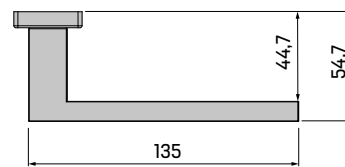

**JUEGO DE MANILLAS KAIROX CR**  
KAIROX CR HANDLE SET

260320 

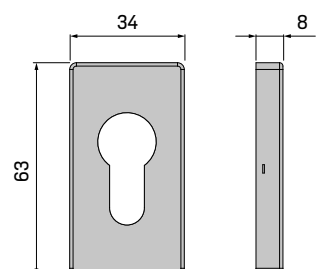
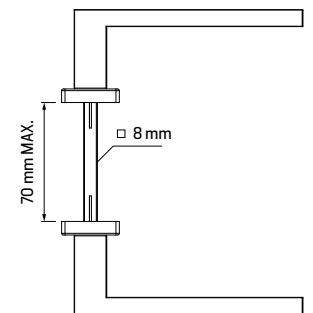

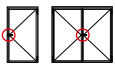

Stainless steel handles with recoverable mechanism for doors.

- Handle, rosette and cylinder cover are made of AISI 304 stainless steel.
- The fixing of the handles is made directly on the profile using self-tapping screws.
- Each handle reference is supplied in handle sets with 8 x 110 mm zinc-plated steel spindle, cylinder covers and screws.
- The handles have been designed with the internal metal mechanism and adjusted and have been tested at 200,000 opening cycles with satisfactory results.

Manillas de acero inoxidable con mecanismo recuperable para puertas.

- Manilla, roseta y embellecedor de bombillo en acero inoxidable AISI 304.
- La fijación de las manillas se realiza directamente sobre el perfil mediante el uso de tornillos roscachapa.
- Cada referencia se suministra en juegos de manillas con cuadradillo en acero zincado de 8 x 110 mm, embellecedores de bombillo y tornillería.
- Las manillas han sido diseñadas con el mecanismo interno metálico y ajustado y han sido testadas a 200,000 ciclos de apertura con resultado satisfactorio.

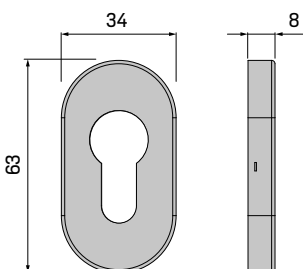
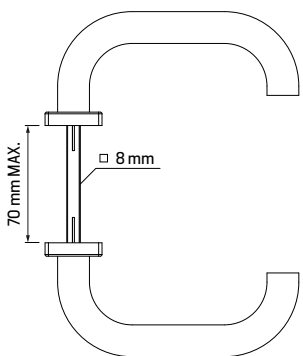
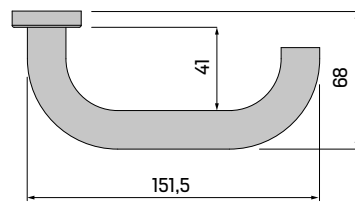
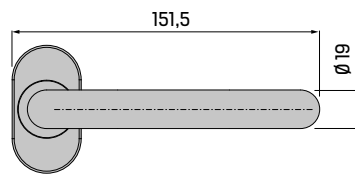
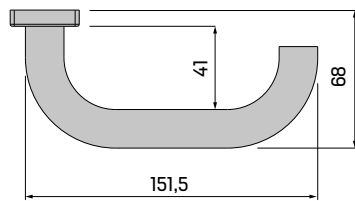
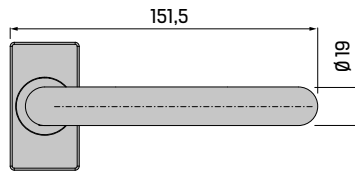
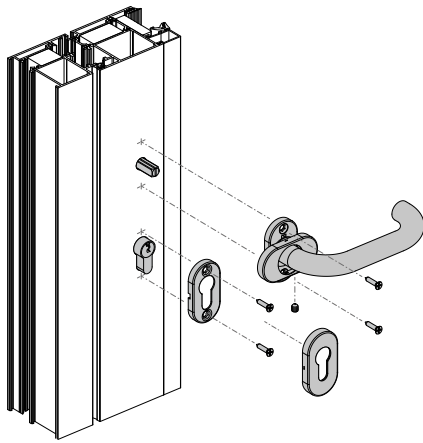

**JUEGO DE MANILLAS KAIROX CRC**  
KAIROX CRC HANDLE SET



260321



**JUEGO DE MANILLAS KAIROX RRC**  
KAIROX RRC HANDLE SET



260221





# TAU

## Línea de tiradores minimalistas Minimalist pull handles range



**Personalización**  
Customization



**Gran variedad de acabados**  
Wide range of finishes



**Alto grado de exigencia**  
High standard



**Robustez contrastada**  
Tested robustness

STAC pone en valor su gama de herrajes para puerta a través del desarrollo de la línea de tiradores minimalistas TAU, que permite ampliar el catálogo de productos y mejorar el valor añadido de los sistemas de cerramiento. La línea TAU ofrece un atractivo especial para los arquitectos y decoradores mediante un diseño elegante, discreto y atemporal. Los tiradores de puerta han sido diseñados considerando la composición geométrica elemental, la simplicidad de las formas, las proporciones y la precisión de los acabados.

### » Diseño minimalista y funcional

Las líneas simples y sofisticadas son las que permanecen en el tiempo. Disponible en configuraciones simple o doble y con grupos rectos o desplazados. La línea de tiradores permite combinar distintas estéticas dando lugar a un diseño cohesivo. Sus múltiples modos de fijación permiten adaptarse a todo tipo de soluciones tanto vanguardistas como más convencionales.

### » Gama completa de acabados anodizados y lacados

Tanto si opta por un acabado superficial lacado o anodizado no sólo aportará valor estético a los tiradores, sino también una protección adicional al aluminio con un mínimo mantenimiento. Con este nuevo concepto de diseño se permite combinar diferentes acabados entre el tirador y los apoyos.

### » Alto grado de exigencia

Los tiradores TAU son la elección perfecta para las aplicaciones que requieren un alto grado de exigencia, como pueden ser puertas con alta frecuencia de uso o de grandes dimensiones.

STAC has enhanced their range of door hardware with the development of a range of pull handles with a minimalist style, thus widening their product range and increasing the added-value of their closure systems. The TAU range is especially attractive to architects and interior designers with its elegant, discreet and timeless design. The pull handles for doors have been designed with primary geometric composition, simplicity of form and proportions and precise finishes taken into consideration.

### » Minimalist and functional design

The simple yet sophisticated lines are those that stand the test of design. Available in single and double configurations, either in-line or offset. This line of pull handles allows distinct styles to come together in a cohesive design. The various fixing options mean the handles are suitable for the most cutting-edge designs as well as more conventional styles.

### » Full range of anodized and lacquered finishes

Whether choosing a lacquered or anodized surface finish, as well as adding a stylish element to the handles, the finish adds a layer of protection to the aluminium and requires the minimum of maintenance. With this new design concept you can combine different finishes between the handle and its support.

### » High standard

TAU door pull handles are the perfect choice for applications requiring a high degree of exigency, such as doors with a high frequency of use or large dimensions.

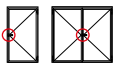

## TIRADOR TAU RECTO STRAIGHT TAU PULL HANDLE

Minimalist pull handle range for entrance doors to public buildings.

- The handles are available in two aesthetics: straight or offset handles.
- Wide range of finishes: natural matt and acier grata anodised or lacquered in any colour from the RAL chart. They allow you to combine finishes between the handle itself and the covers.
- Two fixing kits are available: kit for single pull handle installation or kit for pull handle set.

Tiradores de línea minimalista para puertas de edificios de pública concurrencia.

- Disponibles en dos estéticas: tiradores rectos o desplazados.
- Gran variedad de acabados: anodizados natural mate y acier grata o lacado en cualquier color de la carta RAL. Permiten combinar acabados entre el propio tirador y los embellecedores.
- Disponibles dos kits de fijación: kit para instalación de tirador simple o kit para juego de tiradores.

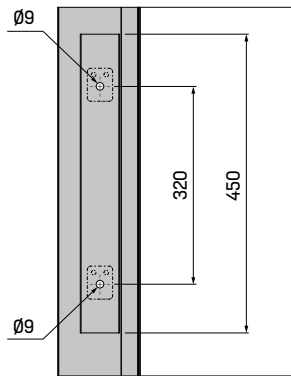
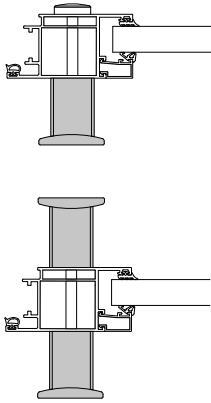

### » KITS DE FIJACIÓN FIXING KITS

**05244002** KIT DE FIJACIÓN PARA CONFIGURACIÓN DE TIRADOR DOBLE  
FIXING KIT FOR DOUBLE PULL HANDLE CONFIGURATION

**05244003** KIT DE FIJACIÓN PARA CONFIGURACIÓN DE TIRADOR SIMPLE  
FIXING KIT FOR SINGLE PULL HANDLE CONFIGURATION

**05244002**

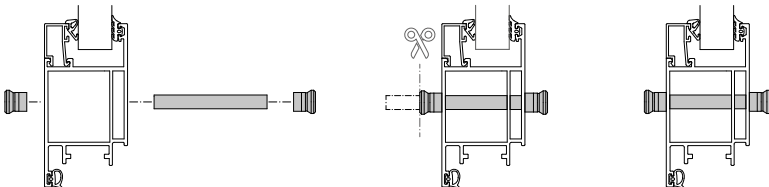

**05244003**

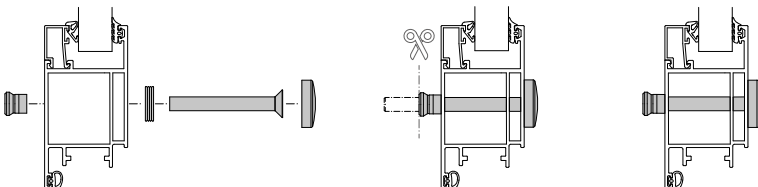

## TIRADOR RECTO STRAIGHT PULL HANDLE



052421

\*\*



## KIT DE EMBELLECEDORES TIRADOR RECTO STRAIGHT PULL HANDLE COVER KIT



052431

\*\*



## TIRADOR RECTO + KIT DE EMBELLECEDORES STRAIGHT PULL HANDLE + COVER KIT



052411

\*\*



## TIRADOR DESPLAZADO TAU TAU OFFSET PULL HANDLE

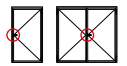

## TIRADOR DESPLAZADO IZQUIERDO LEFT OFFSET PULL HANDLE

052422 \*\* 



\*\*

 RAL

ANODIC

AL ZM

INX AC



allen3

allen5

Tiradores de línea minimalista para puertas de edificios de pública concurrencia.

- Disponibles en dos estéticas: tiradores rectos o desplazados.
- Gran variedad de acabados: anodizados natural mate y acero grata o lacado en cualquier color de la carta RAL. Permiten combinar acabados entre el propio tirador y los embellecedores.
- Disponibles dos kits de fijación: kit para instalación de tirador simple o kit para juego de tiradores.

Minimalist pull handle range for entrance doors to public buildings.

- The handles are available in two aesthetics: straight or offset handles.
- Wide range of finishes: natural matt and acier grata anodised or lacquered in any colour from the RAL chart. They allow you to combine finishes between the handle itself and the covers.
- Two fixing kits are available: kit for single pull handle installation or kit for pull handle set.

## KIT DE EMBELLECEDORES TIRADOR IZQUIERDO LEFT PULL HANDLE COVER KIT

052432 \*\* 



\*\*

 RAL

ANODIC

AL ZM

INX AC



allen3

allen5

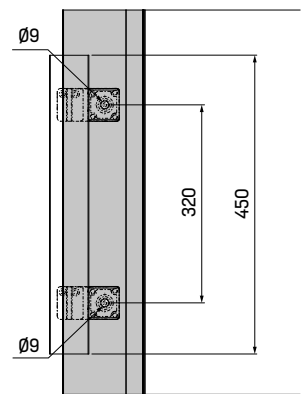
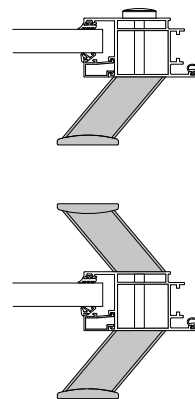

## TIRADOR IZQUIERDO + KIT DE EMBELLECEDORES LEFT PULL HANDLE + COVER KIT

052412 \*\* 



\*\*

 RAL

ANODIC

AL ZM

INX AC



allen3

allen5

### » KITS DE FIJACIÓN FIXING KITS

05244002 **KIT DE FIJACIÓN PARA CONFIGURACIÓN DE TIRADOR DOBLE**  
FIXING KIT FOR DOUBLE PULL HANDLE CONFIGURATION

05244003 **KIT DE FIJACIÓN PARA CONFIGURACIÓN DE TIRADOR SIMPLE**  
FIXING KIT FOR SINGLE PULL HANDLE CONFIGURATION

05244002

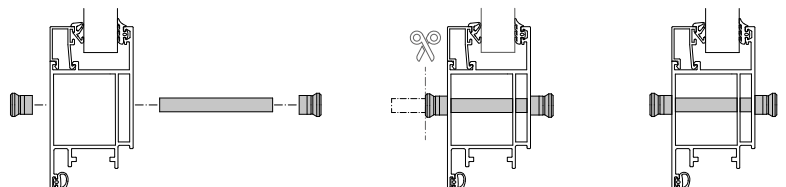

05244003

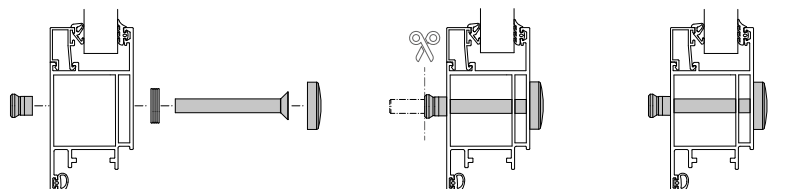

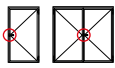

Minimalist pull handle range for entrance doors to public buildings.

- The handles are available in two aesthetics: straight or offset handles.
- Wide range of finishes: natural matt and acier grata anodised or lacquered in any colour from the RAL chart. They allow you to combine finishes between the handle itself and the covers.
- Two fixing kits are available: kit for single pull handle installation or kit for pull handle set.

Tiradores de línea minimalista para puertas de edificios de pública concurrencia.

- Disponibles en dos estéticas: tiradores rectos o desplazados.
- Gran variedad de acabados: anodizados natural mate y acier grata o lacado en cualquier color de la carta RAL. Permiten combinar acabados entre el propio tirador y los embellecedores.
- Disponibles dos kits de fijación: kit para instalación de tirador simple o kit para juego de tiradores.

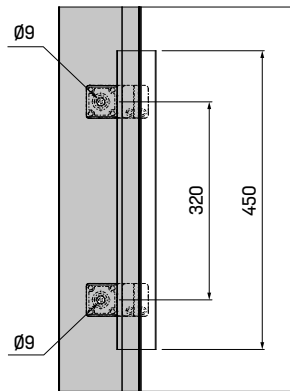
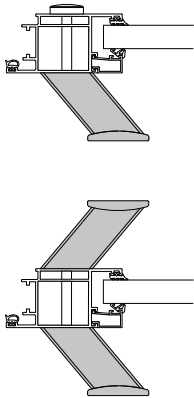

» KITS DE FIJACIÓN FIXING KITS

**05244002** KIT DE FIJACIÓN PARA CONFIGURACIÓN DE TIRADOR DOBLE  
FIXING KIT FOR DOUBLE PULL HANDLE CONFIGURATION

**05244003** KIT DE FIJACIÓN PARA CONFIGURACIÓN DE TIRADOR SIMPLE  
FIXING KIT FOR SINGLE PULL HANDLE CONFIGURATION

**05244002**

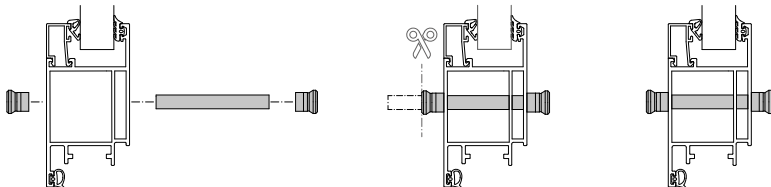

**05244003**

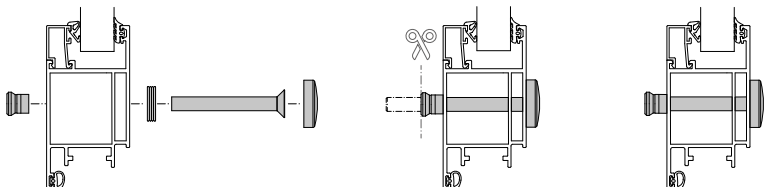

**TIRADOR DESPLAZADO TAU**  
TAU OFFSET PULL HANDLE

**TIRADOR DESPLAZADO DERECHO**  
RIGHT OFFSET PULL HANDLE

\*\*

RAL

ANODIC

AL ZM

INX AC

allen3

allen5

1

**052423** \*\*



**KIT DE EMBELLECEDORES TIRADOR DERECHO**  
RIGHT PULL HANDLE COVER KIT

\*\*

RAL

ANODIC

AL ZM

INX AC

allen3

allen5

2

**052433** \*\*



**TIRADOR DERECHO + KIT DE EMBELLECEDORES**  
RIGHT PULL HANDLE + COVER KIT

\*\*

RAL

ANODIC

AL ZM

INX AC

allen3

allen5

1

**052413** \*\*



## TIRADOR NAOS

### NAOS PULL HANDLE

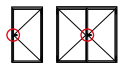

## JUEGO DE TIRADORES NAOS

### NAOS PULL HANDLE SET

0508030 \*\*



Tiradores para puertas de entrada a edificios de pública concurrencia y establecimiento comerciales.

- Los tiradores disponen de un sistema de fijación oculto desde el exterior que evita los intentos de forzamiento y robo.
- Destacan por su sistema de instalación rápido y el mecanizado sencillo de los perfiles.
- Los tiradores están disponibles en juegos o unitariamente.
- Ofrecen la posibilidad de ser lacados en cualquier color de la carta RAL.

Pull handles for entrance doors to commercial establishments and public buildings.

- The pull handles have a concealed fixing system from the outside in order to prevent attempts at forcing and theft.
- They stand out for their quick installation system and the easy machining of the profiles.
- The handles are available in sets or individually.
- They offer the possibility of being lacquered in any colour from the RAL chart.

## TIRADOR NAOS SIMPLE DERECHA

### SIMPLE RIGHT NAOS PULL HANDLE

0508031 \*\*

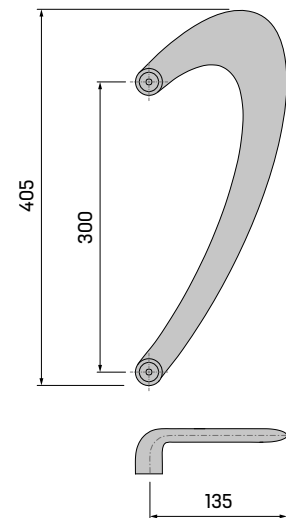

## TIRADOR NAOS SIMPLE IZQUIERDA

### LEFT RIGHT NAOS PULL HANDLE

0508032 \*\*

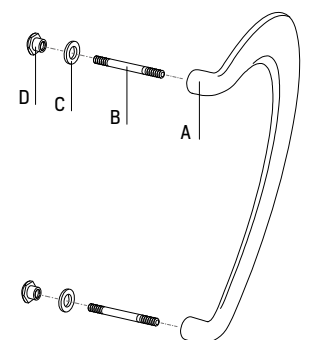
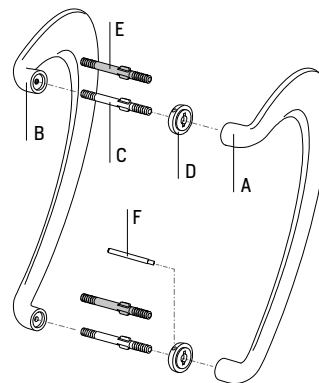

#### DESCRIPCIÓN

#### DESCRIPTION

A	TIRADOR DERECHO RIGHT PULL HANDLE	1
B	TIRADOR IZQUIERDO LEFT PULL HANDLE	1
C	TORNILLOS DERECHOS M8 x 126 mm M8 x 126 mm RIGHT SCREWS	2
D	DISCOS DE FIJACIÓN Ø29x10 mm Ø29x10 mm FIXING PLATES	2
E	TORNILLOS IZQUIERDOS M8 x 126 mm M8 x 126 mm LEFT SCREWS	2
F	LLAVE DE FIJACIÓN FIXING KEY	1

#### DESCRIPCIÓN

#### DESCRIPTION

A	TIRADOR DERECHO RIGHT PULL HANDLE	1
B	TORNILLOS DERECHOS M8 x 114 mm M8 x 114 mm RIGHT SCREWS	2
C	ARANDELAS ACERO INOX STAINLESS STEEL WASHERS	2
D	TUERCAS NUTS	2



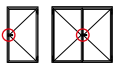

Pull handles for entrance doors to commercial establishments and public buildings.

- The pull handles have a concealed fixing system from the outside in order to prevent attempts at forcing and theft.
- They stand out for their quick installation system and the easy machining of the profiles.
- The handles are available in sets or individually.
- They offer the possibility of being lacquered in any colour from the RAL chart.

Tiradores para puertas de entrada a edificios de pública concurrencia y establecimiento comerciales.

- Los tiradores disponen de un sistema de fijación oculto desde el exterior que evita los intentos de forzamiento y robo.
- Destacan por su sistema de instalación rápido y el mecanizado sencillo de los perfiles.
- Los tiradores están disponibles en juegos o unitariamente.
- Ofrecen la posibilidad de ser lacados en cualquier color de la carta RAL.

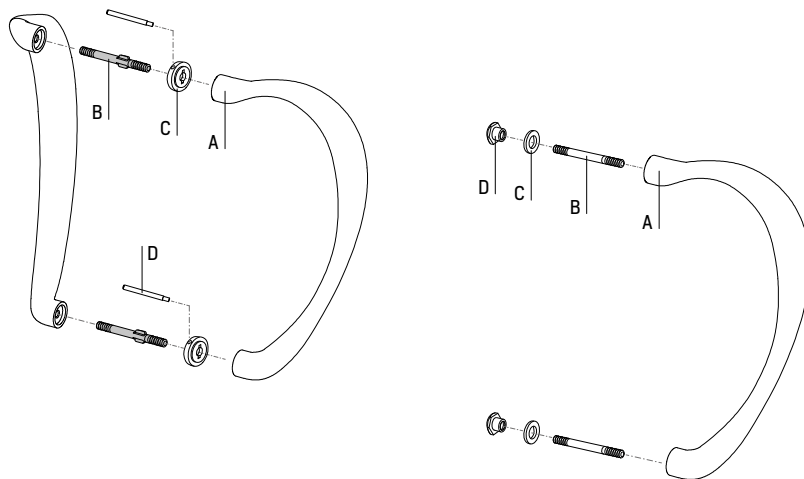
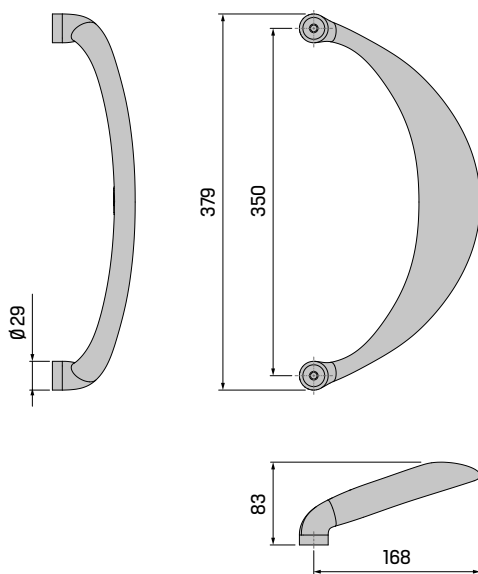

**DESCRIPCIÓN**  
DESCRIPTION



<b>A</b>	<b>TIRADOR</b> PULL HANDLE	2
<b>B</b>	<b>TORNILLOS IZQUIERDOS M8 x 126 mm</b> M8 x 126 mm LEFT SCREWS	2
<b>C</b>	<b>DISCOS DE FIJACIÓN Ø29x10 mm</b> Ø29x10 mm FIXING PLATES	2
<b>D</b>	<b>LLAVE DE FIJACIÓN</b> FIXING KEY	1

**DESCRIPCIÓN**  
DESCRIPTION



<b>A</b>	<b>TIRADOR</b> PULL HANDLE	1
<b>B</b>	<b>TORNILLOS DERECHOS M8 x 114 mm</b> M8 x 114 mm RIGHT SCREWS	2
<b>C</b>	<b>ARANDELAS ACERO INOX</b> STAINLESS STEEL WASHERS	2
<b>D</b>	<b>TUERCAS</b> NUTS	2

**JUEGO DE TIRADORES FÉNIX**  
FENIX PULL HANDLE SET



0508033 \*\*



**TIRADOR SIMPLE FÉNIX**  
FENIX SIMPLE PULL HANDLE



0508034 \*\*



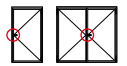

**EMBELLECEDOR SLIM**  
SLIM COVER PLATE

0508053 \*\* 50



\*\*  
ANODIC  
AL  
PH2

Embellecedores de cilindro válidos para cilindros europeos estándar.

- El diseño de la tapa cubretornillos permite ocultar el sistema de fijación.

**Embellecedor SLIM**

- Profundidad de 6,2 mm.
- Línea estética minimalista.
- Disponible en acabado anodizado.

**Embellecedor SIRIUS**

- Profundidad de 8,7 mm.
- Línea estética de las manillas de puerta SIRIUS y POLARIS.

**Embellecedor GÉMINIS**

- Profundidad de 10 mm.
- Línea estética de la manilla GEMINIS.

**Cilindro europeo no incluido.**

Cylinder cover plates valid for standard european cylinders.

- The design of the screw cover allows the fixing system to be hidden.

**SLIM cover plate**

- Depth of 6.2 mm.
- Minimalist aesthetic line.
- Available in anodized finish.

**SIRIUS cover plate**

- Depth of 8.7 mm.
- Aesthetic line of SIRIUS and POLARIS door handles.

**GÉMINIS cover plate**

- Depth of 10 mm.
- Aesthetic line of the GEMINIS handle.

**European cylinder not included.**

**EMBELLECEDOR SIRIUS**  
SIRIUS COVER PLATE

0508029 \*\* 50



\*\*  
RAL  
ZM PE  
PH2

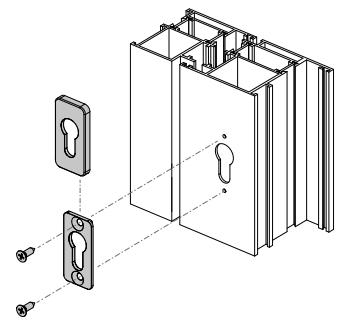
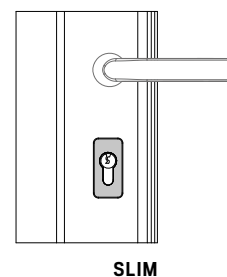
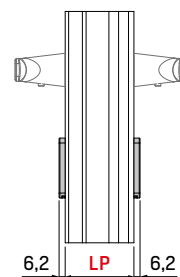

**EMBELLECEDOR GÉMINIS**  
GEMINIS COVER PLATE

0508028 \*\* 50



\*\*  
RAL  
ZM PE  
PH2

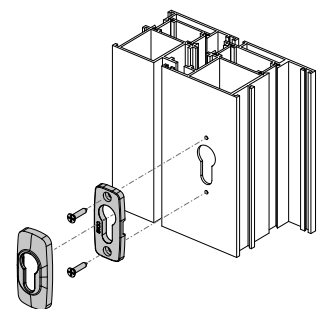
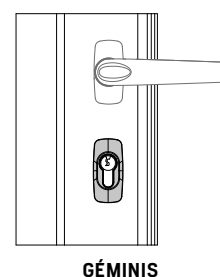
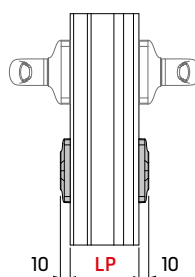
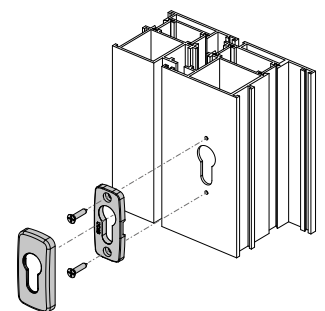
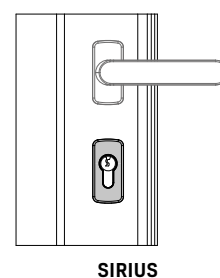
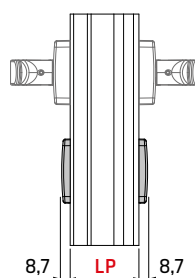

Para seleccionar el cilindro tenga en cuenta:  
**LARGO DEL PERFIL [LP] + PROFUNDIDAD DEL EMBELLECEDOR.**

To select the correct cylinder size, please note:  
**PROFILE LENGTH [LP] + CYLINDER COVER PLATE DEPTH.**

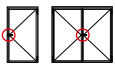

## EMBELLECEDORES DE CILINDRO CYLINDER COVER PLATES

Cylinder cover plates valid for standard european cylinders.

- Depth of 8 mm.
- Aesthetic line of KAIROX door handles.
- The cover plates are made of AISI 304 stainless steel.
- They are available in different aesthetics: straight or rounded trim.
- The design of the screw cover allows the fixing system to be hidden.

European cylinder not included.

Embellecedores de cilindro válidos para cilindros europeos estándar.

- Profundidad de 8 mm.
- Línea estética de las manillas KAIROX.
- Los embellecedores han sido fabricados acero inoxidable AISI 304.
- Están disponibles en diferentes estéticas: embellecedor recto o redondo.
- El diseño de la tapa cubretornillos permite ocultar el sistema de fijación.

Cilindro europeo no incluido.

### EMBELLECEDOR RECTO KAIROX KAIROX STRAIGHT COVER PLATE

INX

20

260100



PH2



### EMBELLECEDOR REDONDO KAIROX KAIROX ROUND COVER PLATE

INX

20

260200



PH2

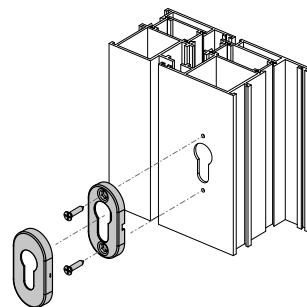
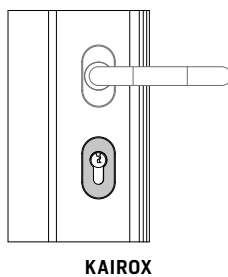
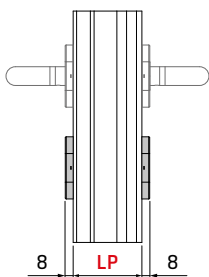
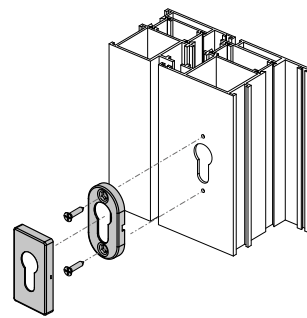
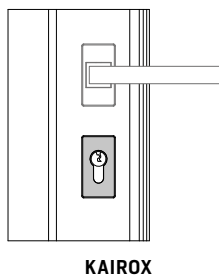
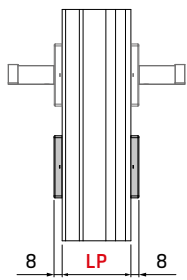

To select the correct cylinder size, please note:  
**PROFILE LENGTH (LP) + CYLINDER COVER PLATE DEPTH.**

Para seleccionar el cilindro tenga en cuenta:  
**LARGO DEL PERFIL (LP) + PROFUNDIDAD DEL EMBELLECEDOR.**

» **KITS DE FIJACIÓN PARA LAS MANILLAS DE PUERTA POLARIS** FIXING KITS FOR POLARIS DOOR HANDLES

-	<b>KIT DE FIJACIÓN ESTÁNDAR</b> STANDARD FIXING KIT	<b>Tornillos roscachapa</b> ( 8x ) Self-tapping screws
KT0518-01	<b>KIT DE FIJACIÓN CON TUERCAS REMACHABLES</b> RIVET NUTS FIXING KIT	<b>Tuercas remachables M5 / Tornillos M5x20 mm</b> ( 8x ) M5 rivet nuts / M5x20 mm screws
KT0518-02	<b>KIT DE FIJACIÓN SECURITY</b> ( D < 60 mm ) SECURITY FIXING KIT	<b>Tuerca ciega / Tornillo M4x65 mm</b> ( 1x ) Cap nut / M4x65 mm screw
KT0518-03	<b>KIT DE FIJACIÓN SECURITY</b> ( 60 < D < 80 mm ) SECURITY FIXING KIT	<b>Tuerca ciega / Tornillo M4x80 mm</b> ( 1x ) Cap nut / M4x80 mm screw

**ESTÁNDAR** STANDARD

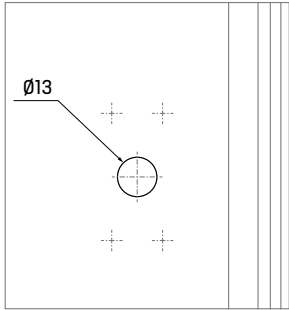

**KT0518-01**

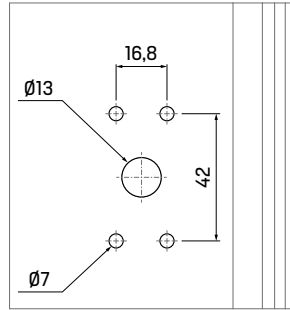

**KT0518-02, KT0518-03**

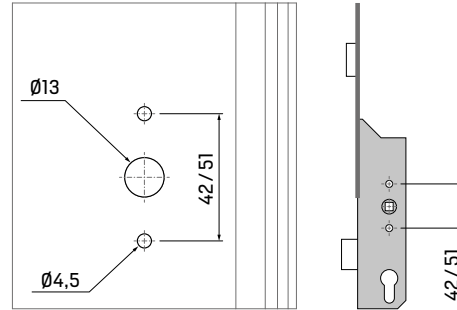

» **KIT DE FIJACIÓN ESTÁNDAR** STANDARD FIXING KIT

8x **Tornillos roscachapa** Self-tapping screws

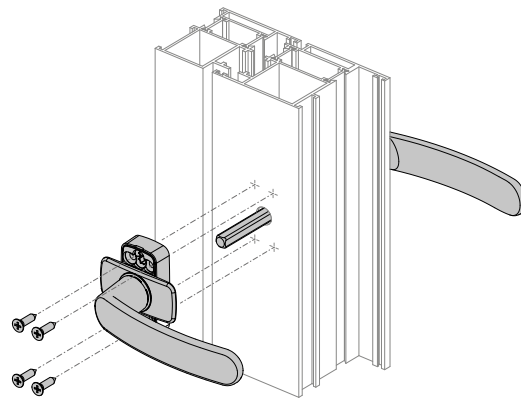
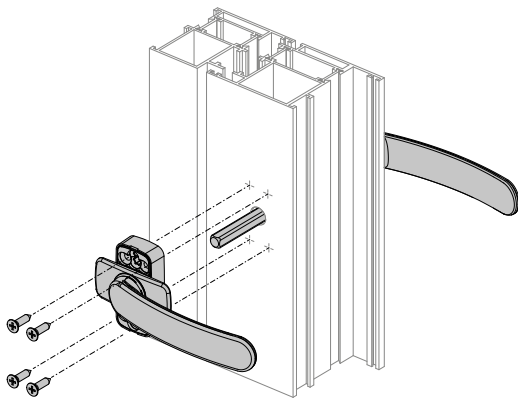

» **KIT DE FIJACIÓN CON TUERCAS REMACHABLES** RIVET NUTS FIXING KIT

8x **Tuercas remachables M5 / Tornillos M5x20 mm** M5 rivet nuts / M5x20 mm screws

**KT0518-01**

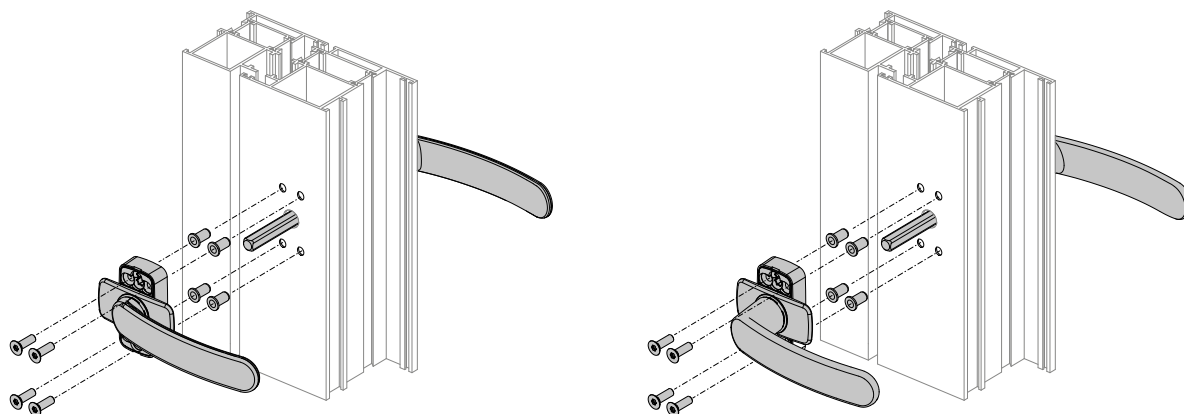

» **KITS DE FIJACIÓN SECURITY** SECURITY FIXING KITS

1x **Tuerca ciega / Tornillo M4x65 mm** Cap nut / M4x65 mm screw

  $D < 60$  mm

**KT0518-02**

1x **Tuerca ciega / Tornillo M4x80 mm** Cap nut / M4x80 mm screw

  $60 < D < 80$  mm

**KT0518-03**

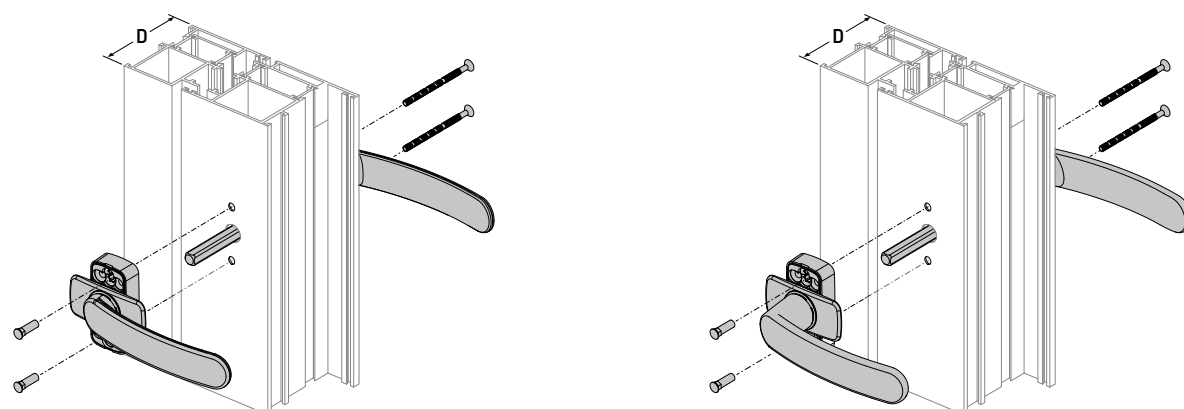



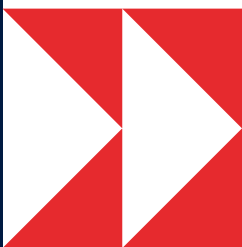

# 04

## APERTURA PRACTICABLE SIDE-HUNG OPENING

- 130 **Kits para apertura practicable**  
Side-hung opening kits
- 132 **Kits con regulación para apertura practicable**  
Adjustable side-hung opening kits
- 133 **Configuraciones de apertura practicable**  
Side-hung opening configurations
- 136 **Kits para apertura exterior**  
Outward opening kits
- 138 **Configuraciones de apertura exterior**  
Outward opening configurations
- 141 **Configuraciones de apertura exterior bidireccional**  
Two-way outward opening configurations



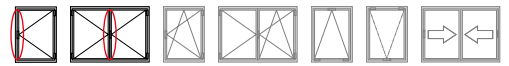

**KITS CON CERRADEROS DE ZAMAK**  
KITS WITH ZAMAK KEEPERS

07K1H

VER TABLA DE REFERENCIAS  
SEE TABLE OF REFERENCES

07K2H

VER TABLA DE REFERENCIAS  
SEE TABLE OF REFERENCES

50

ZM INX

PA

CE

Kits de pasadores y cerraderos para ventanas de apertura practicable.

- Los kits de apertura practicable están disponibles con diámetros Ø6 y Ø8 mm.
- Los kits están disponibles con cerraderos de zamak o cerraderos de plástico.
- Pasadores, punteros, fundas de transmisión y pletinas de unión fabricados en poliamida reforzada con un 20% de fibra de vidrio con el fin de otorgar mayor dureza y resistencia.
- El cerradero de doble hoja permite una regulación progresiva que aumenta el ajuste del cerramiento.

Kits of bolts and keepers for side-hung windows.

- The side-hung opening kits are available with diameters of Ø6 and Ø8 mm.
- The kits are available with zamak or plastic keepers.
- The bolts, pointers, transmission covers and connecting rods are made of polyamide reinforced with 20% glass fibre in order to provide greater hardness and resistance.
- The double sash keeper allows a progressive regulation increasing the adjustment of the closure.

**KITS CON CERRADEROS DE PLÁSTICO**  
KITS WITH PLASTIC KEEPERS

07K1HPA

VER TABLA DE REFERENCIAS  
SEE TABLE OF REFERENCES

07K2HPA

VER TABLA DE REFERENCIAS  
SEE TABLE OF REFERENCES

50

ZM INX

PA

CE

REFERENCIA REFERENCE	CONFIGURACIÓN CONFIGURATION	DIÁMETRO DIAMETER	PUNTEROS POINTERS	CERRADERO KEEPER
07K1H	● HOJA SIMPLE SINGLE SASH	Ø6, Ø8	PA	ZM
07K1HD6		Ø6, Ø8	PA	ZM
07K1HD8		Ø8	PA	ZM
07K1HPA		Ø8	PA	PA
07K2H	● DOBLE HOJA DOUBLE SASH	Ø6, Ø8	PA	ZM
07K2HD6		Ø6, Ø8	PA	ZM
07K2HD8		Ø8	PA	ZM
07K2HPA		Ø8	PA	PA

(●) Las arandelas no se sirven embolsadas Washers are not served bagged

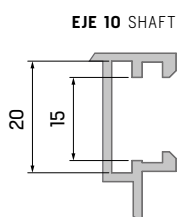

**INVERSOR MARCO / HOJA**  
FRAME INVERTER / SASH

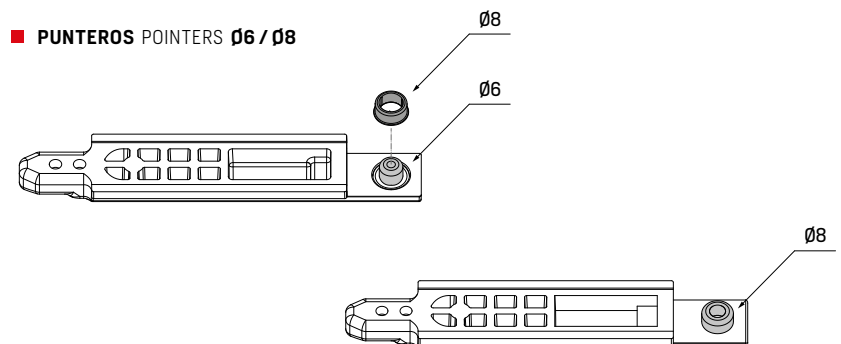



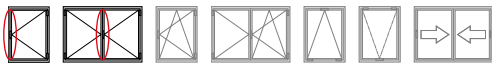

## KITS PARA APERTURA PRACTICABLE SIDE-HUNG OPENING KITS

Kits de pasadores y cerraderos para ventanas de apertura practicable.

- Los kits de apertura practicable están disponibles con diámetros  $\varnothing 6$  y  $\varnothing 8$  mm.
- Los kits están disponibles con punteros, fundas de transmisión y cerraderos fabricados en zamak.
- El cerradero de doble hoja permite una regulación progresiva que aumenta el ajuste del cerramiento.

Kits of bolts and keepers for side-hung windows.

- The side-hung opening kits are available with diameters of  $\varnothing 6$  and  $\varnothing 8$  mm.
- The side-hung opening kits are available with pointers, transmission covers and keepers made of zamak.
- The double sash keeper allows a progressive regulation increasing the adjustment of the closure.

## KITS CON PUNTEROS DE ZAMAK KITS WITH ZAMAK POINTERS

ZM INX

PA

CE



VER TABLA DE REFERENCIAS  
SEE TABLE OF REFERENCES

R07K1H

VER TABLA DE REFERENCIAS  
SEE TABLE OF REFERENCES

R07K2H

50



REFERENCIA REFERENCE	CONFIGURACIÓN CONFIGURATION	DIÁMETRO DIAMETER	PUNTEROS POINTERS	CERRADERO KEEPER
-------------------------	--------------------------------	----------------------	----------------------	---------------------

R07K1H	HOJA SIMPLE SINGLE SASH	$\varnothing 6, \varnothing 8$	ZM	ZM
--------	----------------------------	--------------------------------	----	----

R07K2H	DOBLE HOJA DOUBLE SASH	$\varnothing 6, \varnothing 8$	ZM	ZM
--------	---------------------------	--------------------------------	----	----

## CERRADERO DOBLE REGULABLE DE ZAMAK ZAMAK DOUBLE ADJUSTABLE KEEPER

ZM INX

CE

110501

200

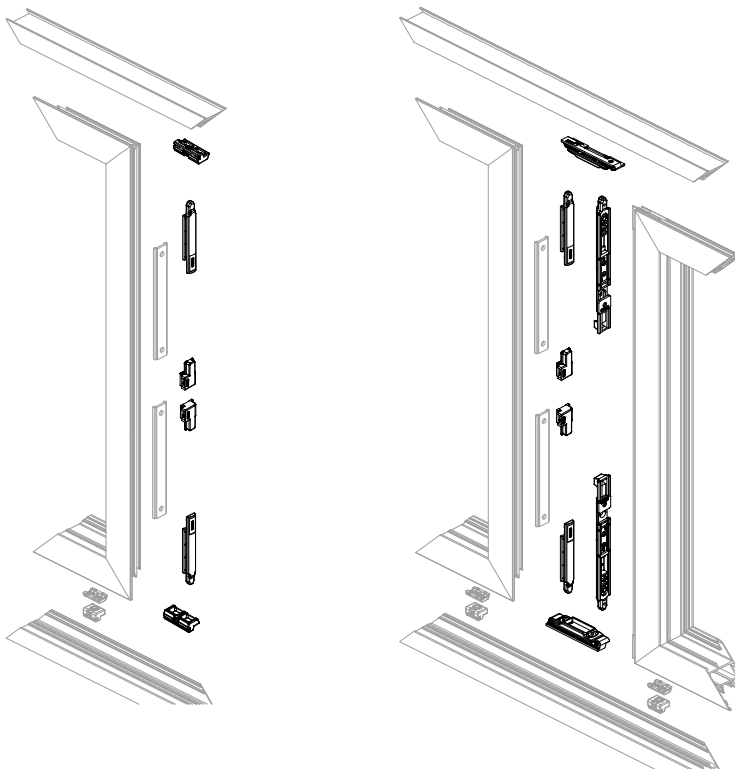

**07K1H 07K1HD6** KIT 1 HOJA  
SINGLE SASH KIT

**07K2H 07K2HD6** KIT 2 HOJAS  
DOUBLE SASH KIT

## CERRADERO DE PLÁSTICO PLASTIC KEEPER

PA INX

0507059

100



EJE 10 SHAFT

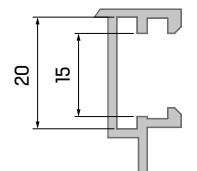

**INVERSOR MARCO / HOJA**  
FRAME INVERTER / SASH

## KITS CON REGULACIÓN PARA APERTURA PRACTICABLE

ADJUSTABLE SIDE-HUNG OPENING KITS

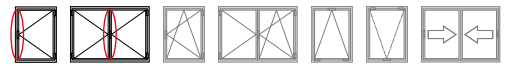

### KITS CON PUNTA METÁLICA Ø6 mm

KITS WITH METALLIC POINT Ø6 mm

07K1HRD6

KIT DE 1 HOJA  
SINGLE SASH KIT

ZM INX

07K2HRD6

KIT DE 2 HOJAS  
DOUBLE SASH KIT

PA

CE



50



Kits que permiten regulación para ventanas de apertura practicables.

- Los punteros están provistos de casquillo y una punta metálica que permite regulación de +1 mm.
- Los kits con regulación están disponibles para hojas pasivas con inversores 15/20 y 13,5/16.8 mm.
- Pasadores, punteros, fundas de transmisión y pletinas de unión se han fabricado en poliamida reforzada con un 20% de fibra de vidrio con el fin de otorgar mayor dureza y resistencia.

Kits that allow adjustment for side-hung opening windows.

- The pointers are equipped with a bushing and a metallic point that allows adjustment of +1 mm.
- Adjustable kits are available for passive sashes with 15/20 and 13.5/16.8 mm inverters.
- The bolts, pointers, transmission covers and connecting rods are made of polyamide reinforced with 20% glass fibre in order to provide greater hardness and resistance.

### KITS HOJA PASIVA CON PUNTA METÁLICA Ø6 mm

PASSIVE SASH KITS WITH METALLIC POINT Ø6 mm

07K3HRD6

KIT HOJA PASIVA  
PASSIVE SASH KIT

ZM INX

07K4HRD6

KIT HOJA PASIVA 13,5 / 16,8  
PASSIVE SASH KIT 13,5/16,8

PA

CE



50



#### ■ AJUSTE DE LOS PUNTEROS CON CASQUILLO DE REGULACIÓN ADJUSTMENT OF THE POINTERS WITH REGULATION BUSHING

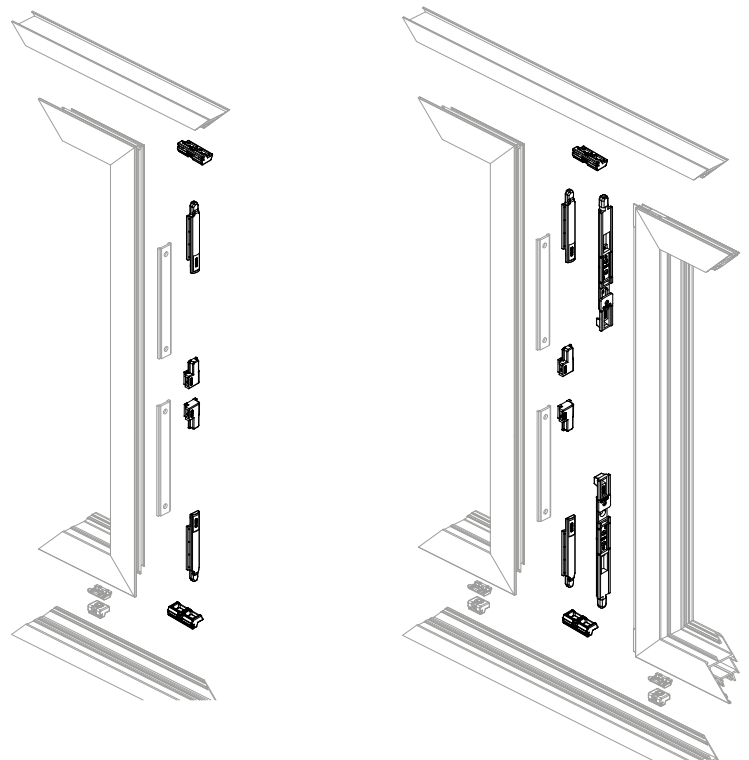
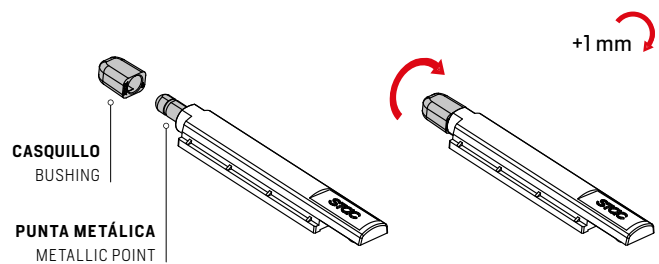

EJE 10 SHAFT

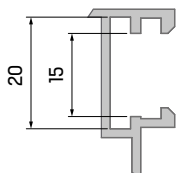

INVERSOR MARCO / HOJA  
FRAME INVERTER / SASH

07K4HRD6

EJE 10 SHAFT

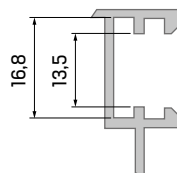

INVERSOR MARCO / MARCO  
FRAME INVERTER / FRAME

07K1HRD6 KIT REGULABLE 1 HOJA  
ADJUSTABLE SINGLE SASH KIT

07K2HRD6 KIT REGULABLE 2 HOJAS  
ADJUSTABLE DOUBLE SASH KIT



**CIERRE AL INVERSOR**  
LOCKING TO INVERTER

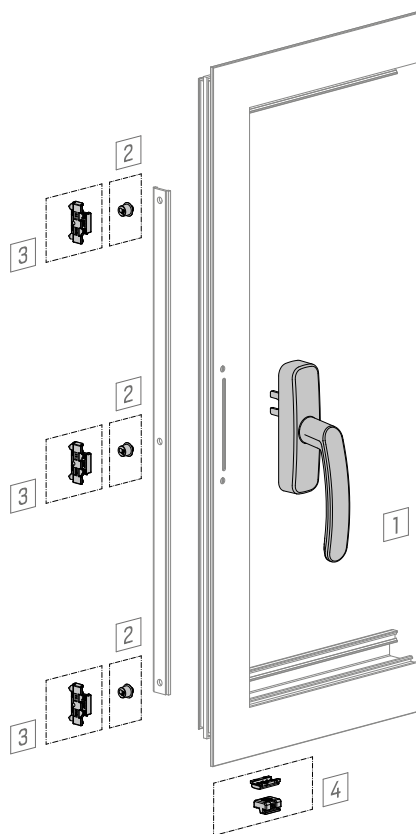
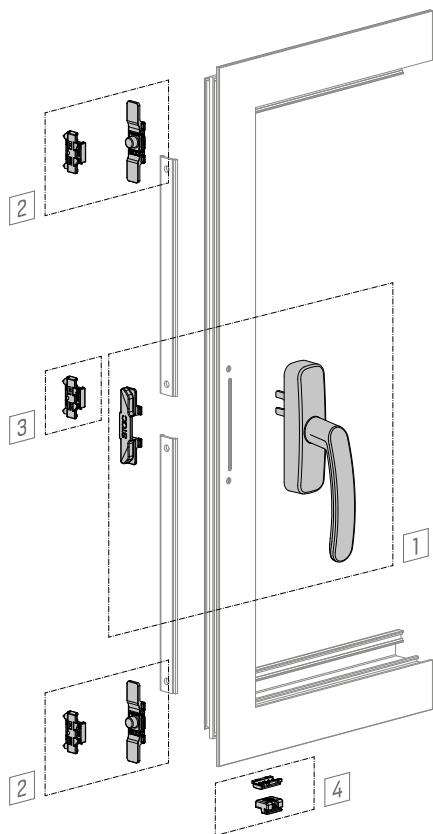

**CON FUNDA DE TRANSMISIÓN**

WITH TRANSMISSION COVER



1	<b>CREMONA SIRIUS O LEO DE APERTURA PRACTICABLE</b> SIRIUS OR LEO SIDE-HUNG WINDOW CREMONE	
2	<b>113000IM KIT PUNTO DE CIERRE SUPLEMENTARIO</b> SUPPLEMENTARY LOCKING POINT KIT	50
3	<b>110200 PUNTO DE CIERRE REGULABLE</b> ADJUSTABLE LOCKING POINT	500
4	<b>0710621 KIT RESBALÓN DE POSICIONAMIENTO</b> POSITIONING LATCH KIT	100

**CON REMACHES (SIN FUNDA DE TRANSMISIÓN)**

WITH RIVETS (WITHOUT TRANSMISSION COVER)



1	<b>CREMONA SIRIUS O LEO DE APERTURA PRACTICABLE</b> SIRIUS OR LEO SIDE-HUNG WINDOW CREMONE	
2	<b>0517002 PUNTO DE CIERRE: REMACHE Ø6</b> LOCKING POINT: RIVET Ø6	50
2	<b>0511088 PUNTO DE CIERRE: REMACHE Ø8</b> LOCKING POINT: RIVET Ø8	50
3	<b>110200 PUNTO DE CIERRE REGULABLE</b> ADJUSTABLE LOCKING POINT	500
4	<b>0710621 KIT RESBALÓN DE POSICIONAMIENTO</b> POSITIONING LATCH KIT	100

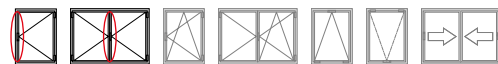

**CIERRE AL MARCO CON ÁNGULO DE REENVÍO Y PUNTERO**  
LOCKING TO FRAME WITH CORNER DRIVE AND POINTER

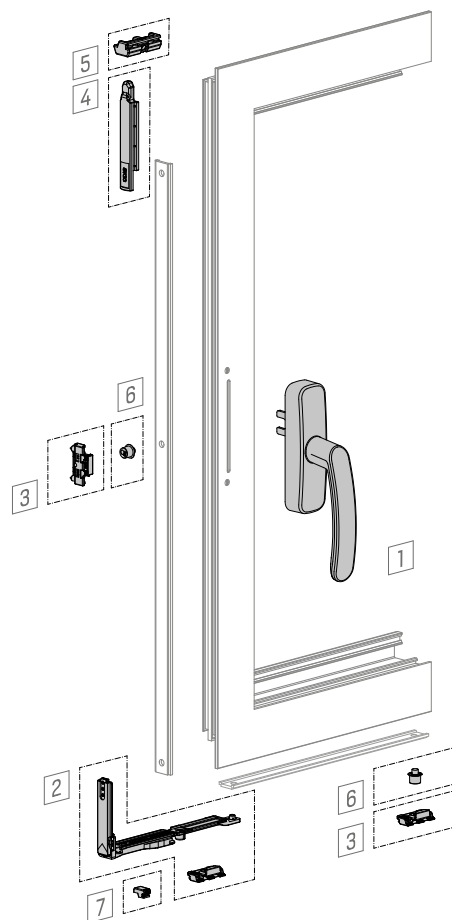
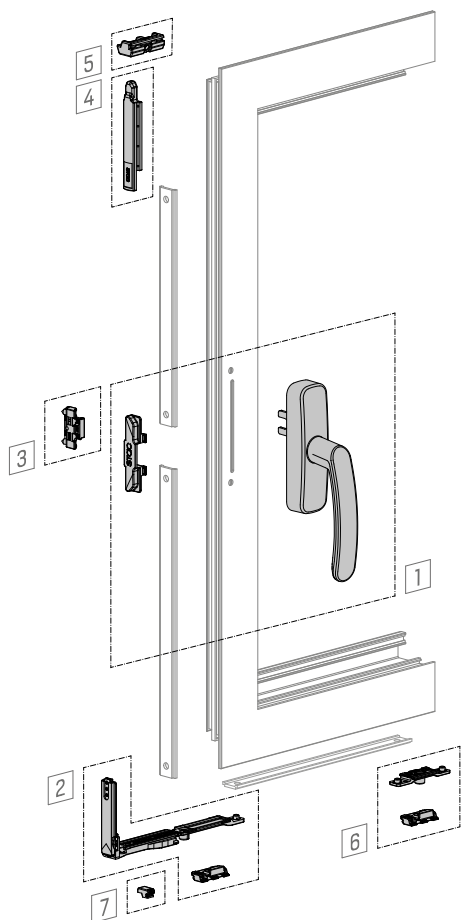

**CON FUNDA DE TRANSMISIÓN**  
WITH TRANSMISSION COVER



1	<b>CREMONA SIRIUS O LEO DE APERTURA PRACTICABLE</b> SIRIUS OR LEO SIDE-HUNG WINDOW CREMONE	
2	<b>113420 KIT ÁNGULO DE REENVÍO HORIZONTAL</b> HORIZONTAL CORNER DRIVE KIT	20
3	<b>110200 PUNTO DE CIERRE REGULABLE</b> ADJUSTABLE LOCKING POINT	500
4	<b>07085 PUNTERO PARA APERTURA PRACTICABLE Ø6</b> Ø6 SIDE-HUNG OPENING POINTER	1000
5	<b>0507105 CERRADERO UNIVERSAL</b> UNIVERSAL KEEPER	50
6	<b>113000IM KIT PUNTO DE CIERRE SUPLEMENTARIO</b> SUPPLEMENTARY LOCKING POINT KIT	50
7	<b>0517193 RESBALÓN DE POSICIONAMIENTO</b> POSITIONING LATCH	100

**CON REMACHES (SIN FUNDA DE TRANSMISIÓN)**  
WITH RIVETS (WITHOUT TRANSMISSION COVER)



1	<b>CREMONA SIRIUS O LEO DE APERTURA PRACTICABLE</b> SIRIUS OR LEO SIDE-HUNG WINDOW CREMONE	
2	<b>113420 KIT ÁNGULO DE REENVÍO HORIZONTAL</b> HORIZONTAL CORNER DRIVE KIT	20
3	<b>110200 PUNTO DE CIERRE REGULABLE</b> ADJUSTABLE LOCKING POINT	500
4	<b>07085 PUNTERO PARA APERTURA PRACTICABLE Ø6</b> Ø6 SIDE-HUNG OPENING POINTER	1000
5	<b>0507105 CERRADERO UNIVERSAL</b> UNIVERSAL KEEPER	50
6	<b>0517002 PUNTO DE CIERRE: REMACHE Ø6</b> LOCKING POINT: RIVET Ø6	50
	<b>0511088 PUNTO DE CIERRE: REMACHE Ø8</b> LOCKING POINT: RIVET Ø8	
7	<b>0517193 RESBALÓN DE POSICIONAMIENTO</b> POSITIONING LATCH	100

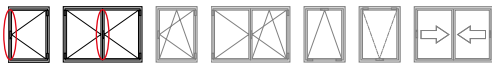

**CIERRE AL MARCO CON DOBLE ÁNGULO DE REENVÍO**  
LOCKING TO FRAME WITH DOUBLE CORNER DRIVE

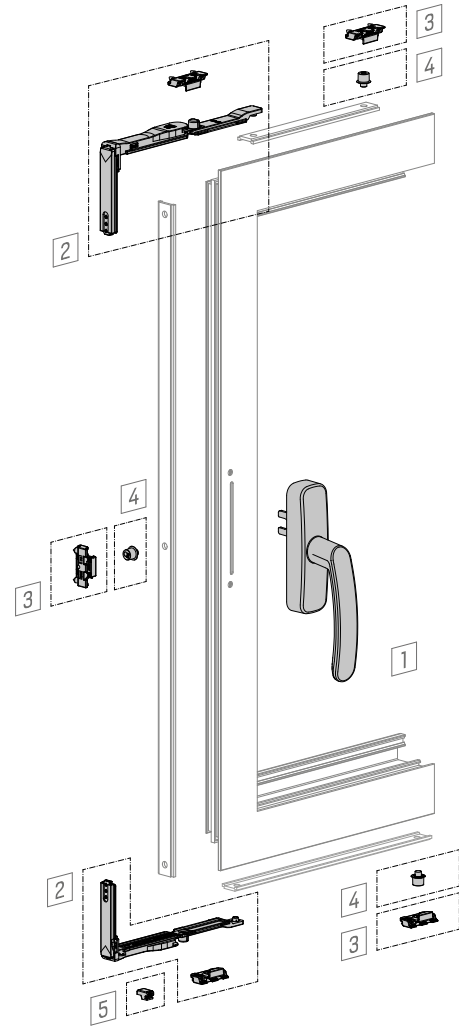
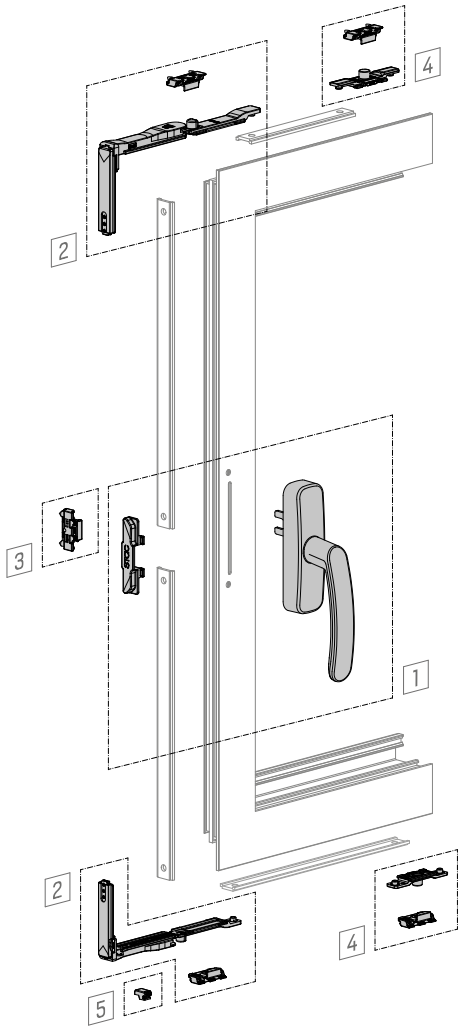

**CON REMACHES (SIN FUNDA DE TRANSMISIÓN)**  
WITH RIVETS (WITHOUT TRANSMISSION COVER)



1	<b>CREMONA SIRIUS O LEO DE APERTURA PRACTICABLE</b> SIRIUS OR LEO SIDE-HUNG WINDOW CREMONE	
2	<b>113420 KIT ÁNGULO DE REENVÍO HORIZONTAL</b> HORIZONTAL CORNER DRIVE KIT	20
3	<b>110200 PUNTO DE CIERRE REGULABLE</b> ADJUSTABLE LOCKING POINT	500
4	<b>113000IM KIT PUNTO DE CIERRE SUPLEMENTARIO</b> SUPPLEMENTARY LOCKING POINT KIT	50
5	<b>0517193 RESBALÓN DE POSICIONAMIENTO</b> POSITIONING LATCH	100

**CON REMACHES (SIN FUNDA DE TRANSMISIÓN)**  
WITH RIVETS (WITHOUT TRANSMISSION COVER)



1	<b>CREMONA SIRIUS O LEO DE APERTURA PRACTICABLE</b> SIRIUS OR LEO SIDE-HUNG WINDOW CREMONE	
2	<b>113420 KIT ÁNGULO DE REENVÍO HORIZONTAL</b> HORIZONTAL CORNER DRIVE KIT	20
3	<b>110200 PUNTO DE CIERRE REGULABLE</b> ADJUSTABLE LOCKING POINT	500
4	<b>0517002 PUNTO DE CIERRE: REMACHE Ø6</b> LOCKING POINT: RIVET Ø6	50
	<b>0511088 PUNTO DE CIERRE: REMACHE Ø8</b> LOCKING POINT: RIVET Ø8	
5	<b>0517193 RESBALÓN DE POSICIONAMIENTO</b> POSITIONING LATCH	100

## KITS PARA APERTURA EXTERIOR

OUTWARD OPENING KITS

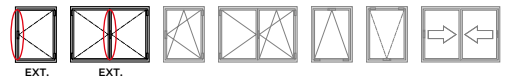

### KIT APERTURA EXTERIOR CON BULÓN CORTO

OUTWARD OPENING KIT WITH SHORT BOLT

074K01C

20



ZM INX

PA

CE



Kits de accesorios que permiten la transmisión en ventanas de apertura exterior.

- Los kits para apertura exterior se suministran con transmisión, bulón, deslizaderas y puntos de cierre regulables.
- Disponibles 2 kits de transmisión con bulón (corto y largo) formados por una pieza de transmisión y un bulón.
- Disponible listado de configuraciones para múltiples series.

Consulte las cremonas HYDRA para apertura exterior en la página 94.

Accessory kits that allow transmission on outward opening windows.

- The outward opening kits are supplied with transmission, bolt, sliders and adjustable locking points.
- Available 2 transmission kits with bolt (short and long) consisting of a transmission piece and a bolt.
- List of configurations for multiple series available.

See outward opening HYDRA cremones on page 94.

### KIT APERTURA EXTERIOR CON BULÓN LARGO

OUTWARD OPENING KIT WITH LONG BOLT

074K01L

20



ZM INX

PA

CE

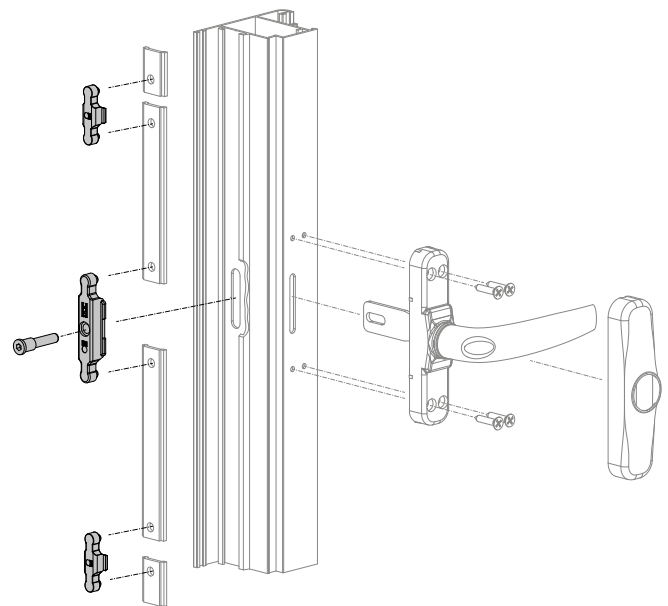

### KIT APERTURA EXTERIOR CON BULÓN ESPECIAL

OUTWARD OPENING KIT WITH SPECIAL BOLT

075K01CE1

20



ZM INX

PA

CE



REFERENCIA REFERENCE	DESCRIPCIÓN DESCRIPTION	BULÓN BOLT
-------------------------	----------------------------	---------------

074K01C	<b>KIT DE TRANSMISIÓN + BULÓN CORTO</b> TRANSMISSION KIT + SHORT BOLT	07044
---------	--	-------

074K01L	<b>KIT DE TRANSMISIÓN + BULÓN LARGO</b> TRANSMISSION KIT + LONG BOLT	07060
---------	---	-------

075K01CE1	<b>KIT DE TRANSMISIÓN + BULÓN ESPECIAL</b> TRANSMISSION KIT + SPECIAL BOLT	07129
-----------	---	-------

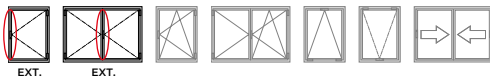

## KITS PARA APERTURA EXTERIOR OUTWARD OPENING KITS

Accessory kits that allow transmission on outward opening windows.

- The outward opening kits are supplied with transmission, bolt, sliders and adjustable locking points.
- Available 2 transmission kits with bolt (short and long) consisting of a transmission piece and a bolt.
- Bolts available in 3 sizes: short, long and special length.

See outward opening HYDRA cremones on page 94.

Kits de accesorios que permiten la transmisión en ventanas de apertura exterior.

- Los kits para apertura exterior se suministran con transmisión, bulón, deslizaderas y puntos de cierre regulables.
- Disponibles 2 kits de transmisión con bulón (corto y largo) formados por una pieza de transmisión y un bulón.
- Bulones disponibles en 3 tamaños: corto, largo y longitud especial.

Consulte las cremonas HYDRA para apertura exterior en la página 94.

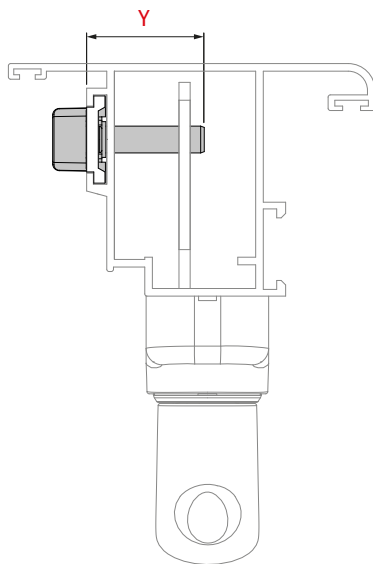

### KIT DE TRANSMISIÓN + BULÓN CORTO SHORT BOLT + TRANSMISSION KIT

ZM INX

074K01

20



### KIT DE TRANSMISIÓN + BULÓN LARGO LONG BOLT + TRANSMISSION KIT

ZM INX

075K01

20



### BULONES BOLTS

INX

07044

07060

07129



REFERENCIA REFERENCE	DESCRIPCIÓN DESCRIPTION	LONGITUD Y Y LENGTH
07044	<b>BULÓN CORTO</b> SHOT BOLT	19 mm
07060	<b>BULÓN LARGO</b> LONG BOLT	26 mm
07129	<b>BULÓN ESPECIAL</b> SPECIAL BOLT	36 mm

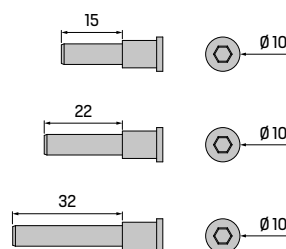

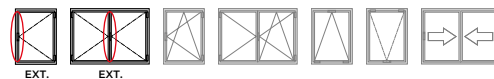

**CIERRE AL MARCO CON ÁNGULO DE REENVÍO Y PUNTERO**  
LOCKING TO FRAME WITH CORNER DRIVE AND POINTER

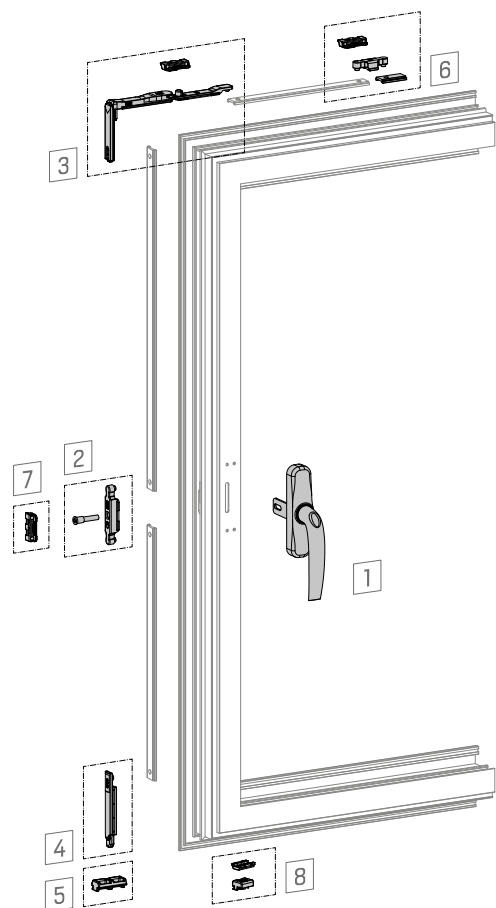

**CON ÁNGULO DE REENVÍO Y PUNTERO**  
WITH CORNER DRIVE AND POINTER



1	<b>CREMONA HYDRA PARA APERTURA EXTERIOR</b> HYDRA OUTWARD OPENING CREMONE	15
	<b>074K01 KIT DE TRANSMISIÓN + BULÓN CORTO</b> TRANSMISSION KIT + SHORT BOLT	
2	<b>075K01 KIT DE TRANSMISIÓN + BULÓN LARGO</b> TRANSMISSION KIT + LONG BOLT	20
3	<b>113420 KIT ÁNGULO DE REENVÍO HORIZONTAL</b> HORIZONTAL CORNER DRIVE KIT	20
4	<b>07085 PUNTERO APERTURA PRACTICABLE Ø6</b> Ø6 SIDE-HUNG OPENING POINTER	1000

5	<b>0507105 CERRADERO UNIVERSAL</b> UNIVERSAL KEEPER	50
6	<b>113000 KIT PUNTO DE CIERRE SUPLEMENTARIO</b> SUPPLEMENTARY LOCKING POINT KIT	50
7	<b>110200 PUNTO DE CIERRE REGULABLE</b> ADJUSTABLE LOCKING POINT	500
8	<b>0710621 KIT RESBALÓN DE POSICIONAMIENTO</b> POSITIONING LATCH KIT	100

**La configuración puede realizarse con remaches** The configuration can be done with rivets



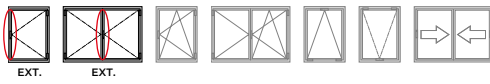

**CIERRE AL MARCO CON DOBLE ÁNGULO DE REENVÍO**  
LOCKING TO FRAME WITH DOUBLE CORNER DRIVE

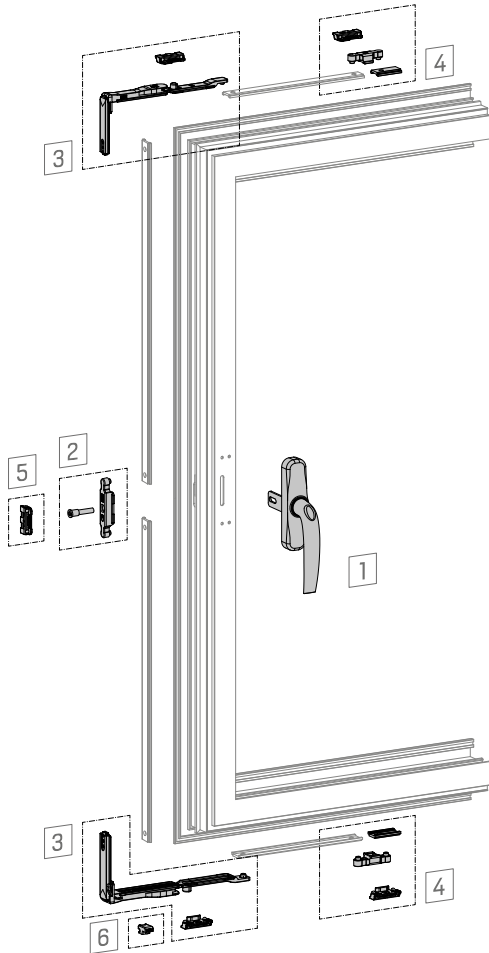

**CON DOBLE ÁNGULO DE REENVÍO**  
WITH DOUBLE CORNER DRIVE



1	<b>CREMONA HYDRA PARA APERTURA EXTERIOR</b> HYDRA OUTWARD OPENING CREMONE	15
2	<b>074K01 KIT DE TRANSMISIÓN + BULÓN CORTO</b> TRANSMISSION KIT + SHORT BOLT	20
	<b>075K01 KIT DE TRANSMISIÓN + BULÓN LARGO</b> TRANSMISSION KIT + LONG BOLT	
3	<b>113420 KIT ÁNGULO DE REENVÍO HORIZONTAL</b> HORIZONTAL CORNER DRIVE KIT	20

4	<b>113000 KIT PUNTO DE CIERRE SUPLEMENTARIO</b> SUPPLEMENTARY LOCKING POINT KIT	50
5	<b>110200 PUNTO DE CIERRE REGULABLE</b> ADJUSTABLE LOCKING POINT	500
6	<b>0517193 RESBALÓN DE POSICIONAMIENTO</b> POSITIONING LATCH	100

**La configuración puede realizarse con remaches** The configuration can be done with rivets

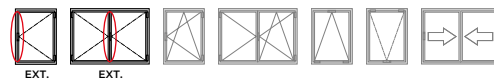

**CIERRE AL INVERSOR**  
LOCKING TO INVERTER

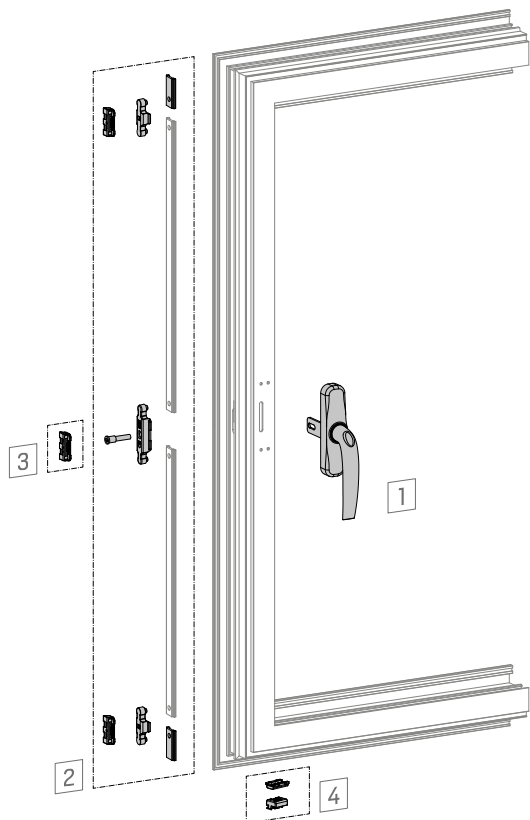

**CIERRE AL INVERSOR**  
LOCKING TO INVERTER



1	<b>CREMONA HYDRA PARA APERTURA EXTERIOR</b> HYDRA OUTWARD OPENING CREMONE	15
2	<b>074K01C</b> <b>KIT APERTURA EXTERIOR CON BULÓN CORTO</b> OUTWARD OPENING KIT WITH SHORT BOLT	25
	<b>074K01L</b> <b>KIT APERTURA EXTERIOR CON BULÓN LARGO</b> OUTWARD OPENING KIT WITH LONG BOLT	100
3	<b>110200</b> <b>PUNTO DE CIERRE REGULABLE</b> ADJUSTABLE LOCKING POINT	500
4	<b>0710621</b> <b>KIT RESBALÓN DE POSICIONAMIENTO</b> POSITIONING LATCH KIT	100

**La configuración puede realizarse con remaches** The configuration can be done with rivets

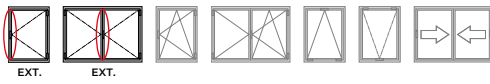

**CAJA DE TRANSMISIÓN BIDIRECCIONAL**  
TWO-WAY GEARBOX

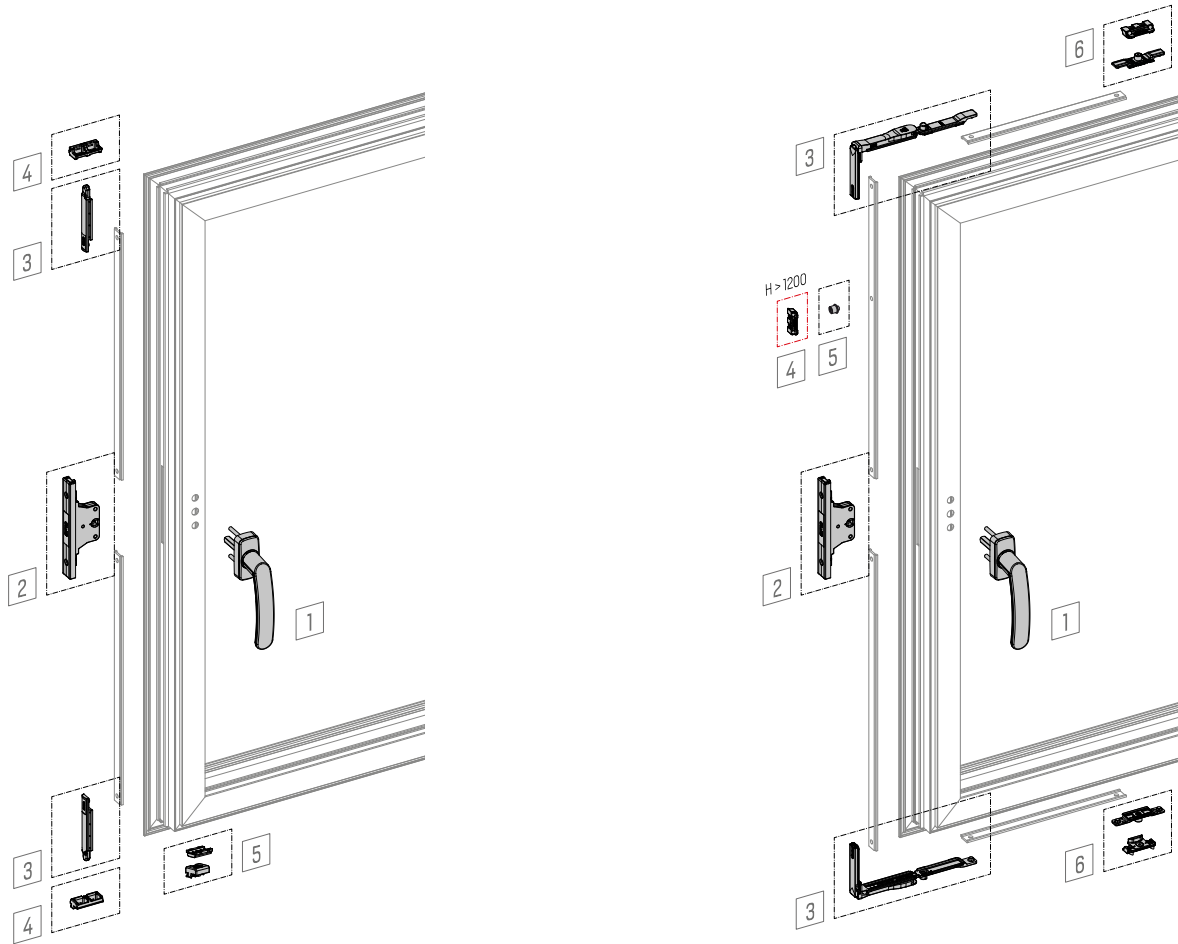

**CON DOBLE PUNTERO**  
WITH DOUBLE POINTER



1	<b>MANILLA POLARIS PARA APERTURA EXTERIOR</b> POLARIS OUTWARD OPENING HANDLE	20
2	<b>0507248 CAJA DE TRANSMISIÓN BIDIRECCIONAL</b> TWO-WAY GEARBOX	25
3	<b>07085 PUNTERO APERTURA PRACTICABLE Ø6</b> Ø6 SIDE-HUNG OPENING POINTER	1000
4	<b>0507105 CERRADERO UNIVERSAL</b> UNIVERSAL KEEPER	50
5	<b>0710621 KIT RESBALÓN DE POSICIONAMIENTO</b> POSITIONING LATCH KIT	100

**CON DOBLE ÁNGULO DE REENVÍO**  
WITH DOUBLE CORNER DRIVE



1	<b>MANILLA POLARIS PARA APERTURA EXTERIOR</b> POLARIS OUTWARD OPENING HANDLE	20
2	<b>0507248 CAJA DE TRANSMISIÓN BIDIRECCIONAL</b> TWO-WAY GEARBOX	25
3	<b>113420 KIT ÁNGULO DE REENVÍO HORIZONTAL</b> HORIZONTAL CORNER DRIVE KIT	20
4	<b>110200 PUNTO DE CIERRE REGULABLE</b> ADJUSTABLE LOCKING POINT	500
5	<b>0517002 PUNTO DE CIERRE: REMACHE Ø6</b> LOCKING POINT: RIVET Ø6	50
6	<b>113000IM KIT PUNTO DE CIERRE SUPLEMENTARIO</b> SUPPLEMENTARY LOCKING POINT KIT	50

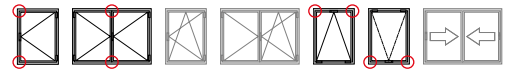

**ÁNGULO DE REENVÍO PARA CIERRE AL MARCO**  
LOCKING TO FRAME CORNER DRIVE

113420

ZM INX



20



Ángulo de reenvío válido para ventanas practicables, proyectantes o abatibles.

The corner drive is valid for side-hung, top-hung and bottom-hung windows.

- El kit para cierre al marco se suministra con un ángulo de reenvío horizontal y un punto de cierre regulable.

- The frame locking kit is supplied with a horizontal corner drive and an adjustable locking point.

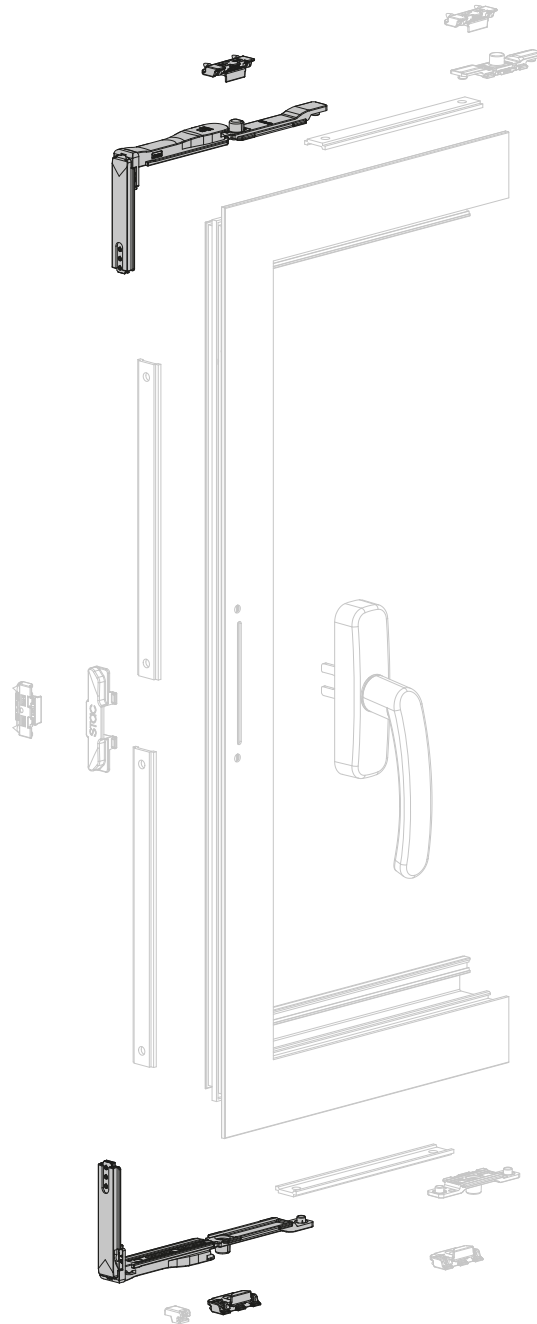

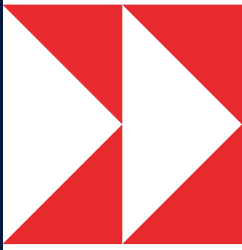

# 05

## APERTURA OSCILOBATIENTE TILT & TURN OPENING

- 144 **Kits oscilobatientes CH180+**  
CH180+ tilt & turn kits
- 148 **Kits oscilobatientes CLX**  
CLX tilt & turn kits
- 152 **Kits oscilobatientes CLASSIC**  
CLASSIC tilt & turn kits
- 158 **Kits oscilobatientes SMART**  
SMART tilt & turn kits
- 164 **Compases oscilobatientes**  
Tilt & turn friction stays
- 166 **Compases**  
Friction stays
- 167 **Ángulos de reenvío suplementarios**  
Supplementary corner drives
- 168 **Embalaje industrial**  
Bulk packaging
- 172 **Notas técnicas**  
Technical notes





# CH180+

bisagra oculta concealed hinge



Perfiles de Canal Europeo  
Euro Groove profiles



Apertura total  
Full opening



Montaje simple y rápido  
Simple & quick installation



Regulación tridimensional  
Three-dimensional adjustment

La tendencia en la arquitectura y el diseño hacia espacios puros y sencillos ha hecho que los sistemas de cerramiento hayan tenido que evolucionar hacia sistemas con huecos y aperturas de mayores dimensiones en los que se busca que el protagonismo lo tenga la luz y que los accesorios queden reducidos a lo esencial. Respondiendo a esta necesidad nace la bisagra CH180+, compatible con todo el herraje oscilobatiente de Canal Europeo desarrollado por STAC.

## » Apertura de 180°

A través de la simplificación y configuración de la cinemática de articulación, que permite realizar una apertura de 180° sin apenas movimientos parásitos, se ha conseguido suavizar el movimiento y aumentado el confort de uso.

## » Simplicidad en el montaje

Como todos los herrajes de STAC, la bisagra ha sido desarrollada pensando en el instalador. A este efecto, todos los elementos se suministran pre-montados y no es necesario hacer ningún tipo de mecanizado ni operación especial sobre los perfiles. A nivel bisagra inferior podemos considerar dos partes bien diferenciadas que se pre-montan sobre marco y hoja, y finalmente se unen en el ensamblaje de hoja sobre el marco.

## » Regulación tridimensional

Las bisagras incorporan regulación 3D para favorecer los ajustes en obra. Todos los puntos de regulación han sido dispuestos en zonas de fácil acceso y pueden realizarse con la hoja en carga.

- Regulación vertical: +2 / - 0.5 mm
- Regulación lateral: ±1,5 mm
- Regulación de presión: +0.5 mm

The trend in architecture and design for pure, simple spaces and objects has meant that closure systems have had to evolve in this direction, offering systems with ever larger fenestrations and doors / windows to make the light the leading element. This has meant that accessories have been reduced to the bare essentials. In response to this demand, we are pleased to launch the CH180+ concealed hinge, compatible with all Euro Groove tilt & turn hardware developed by STAC.

## » 180° opening

STAC has managed to simplify the kinematics of the joint and it is configured in a manner which allows 180° opening with hardly any wasteful movement. This means that the movement is softer and increases user comfort.

## » Simple installation

Like all STAC hardware, the hinges have been designed with the fitter in mind. To this end, all parts are supplied pre-assembled and no type of machining or special operations on the profiles is required. In the lower hinge, there are two well differentiated parts which are pre-mounted to the frame and sash and they are then attached together during the assembly of the sash into the frame.

## » Three-dimensional adjustment

The hinges incorporate 3D adjustment to make on-site adjustments easier. All adjustment points are located in easy-to-reach areas and can be regulated with the leaf in place.

- Vertical adjustment: +2 / - 0.5 mm
- Lateral adjustment: ±1,5 mm
- Tightening adjustment: +0.5 mm

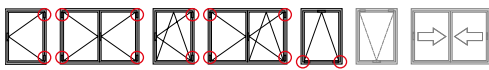

CH180+ concealed hinges for side-hung and tilt & turn windows.

- Maximum sash opening: 180°.
- Maximum load per sash: 100 kg.
- The compatible supplementary corner drives are H122100 and H122100S.

**CH180+ upper hinge**

- Active sash: the hinge is supplied with a built-in tilt & turn friction stay.
- Passive sash: the hinge allows the assembly of side-hung opening kits.

**CH180+ lower hinge**

- Vertical adjustment: + 2, - 0,5 mm.
- Lateral adjustment: ± 1,5 mm.
- Tightening adjustment: ± 0,5 mm.

Bisagras ocultas CH180+ para ventanas practicables y oscilobatientes.

- Apertura máxima de hoja: 180°.
- Carga máxima por hoja: 100 kg.
- Los ángulos de reenvío suplementarios compatibles son: H122100 / H122100S.

**Bisagra CH180+ superior**

- Hoja activa: la bisagra se suministra con compás oscilobatiente incorporado.
- Hoja pasiva: la bisagra permite el montaje de kits para apertura practicable.

**Bisagra CH180+ inferior**

- Regulación vertical: + 2, - 0,5 mm.
- Regulación lateral: ± 1,5 mm.
- Regulación de presión: ± 0,5 mm.

» **REGULACIONES DE LAS BISAGRAS SUPERIORES** UPPER HINGES ADJUSTMENTS

**BISAGRA DE HOJA PASIVA** PASSIVE SASH HINGE

- ALLEN 3 (±1,5) **REGULACIÓN DE PRESIÓN** TIGHTENING ADJUSTMENT
- ALLEN 4 (±3) **REGULACIÓN DE DESCUELQUE** SLIPPING ADJUSTMENT

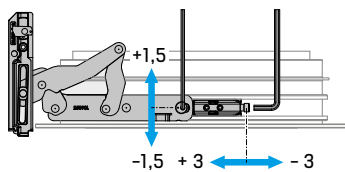

**BISAGRA DE HOJA ACTIVA** ACTIVE SASH HINGE

- ALLEN 3 (±1) **REGULACIÓN DE PRESIÓN** TIGHTENING ADJUSTMENT
- ALLEN 4 (±3) **REGULACIÓN DE DESCUELQUE** SLIPPING ADJUSTMENT

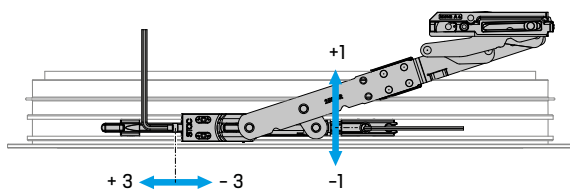

» **REGULACIONES DE LAS BISAGRAS INFERIORES** LOWER HINGES ADJUSTMENTS

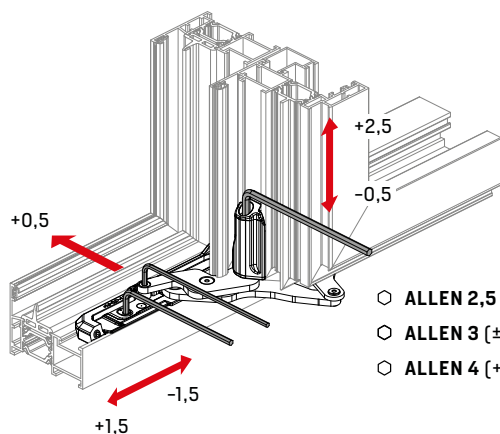

- ALLEN 2,5 (+0,5)
- ALLEN 3 (±1,5)
- ALLEN 4 (+2,5 -0,5)

**BISAGRAS CH180+ CON COMPÁS GRANDE**  
CH180+ HINGES WITH LARGE FRICTION STAY



		1	H1213	R1	L1
		1	H1213	R2	L2



**BISAGRAS CH180+ CON COMPÁS PEQUEÑO**  
CH180+ HINGES WITH SMALL FRICTION STAY



		1	H1213	R3	L3
		1	H1213	R4	L4



**BISAGRAS CH180+ PARA APERTURA PRACTICABLE**  
CH180+ HINGES FOR SIDE-HUNG OPENING



1	H1214	R	L
---	-------	---	---



**BISAGRAS CH180+ PARA APERTURA ABATIBLE**  
CH180+ HINGES FOR BOTTOM-HUNG OPENING



1	H1215
---	-------



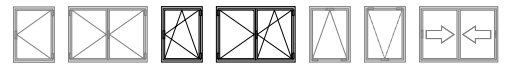

**MANIOBRA LÓGICA CON COMPÁS GRANDE**  
TILT-BEFORE-TURN WITH LARGE FRICTION STAY

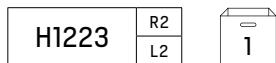

Kits para ventanas oscilobatientes con bisagras CH180+.

- Apertura máxima de hoja: 180°.
- Carga máxima por hoja: 100 kg.
- Los ángulos de reenvío suplementarios compatibles son: H122100 / H122100S.

**Bisagra CH180+ superior**

- Regulación lateral:  $\pm 3$  mm.
- Regulación de presión:  $\pm 1$  mm.

**Bisagra CH180+ inferior**

- Regulación vertical: + 2, - 0,5 mm.
- Regulación lateral:  $\pm 1,5$  mm.
- Regulación de presión:  $\pm 0,5$  mm.

**Herraje EVO-SOFT**

- El esfuerzo de cierre del herraje es hasta un 50% menor en comparación con el uso de herraje tradicional.
- Posibilidad de añadir múltiples puntos de cierre.
- Todos los elementos deslizantes incorporan un clip antiholguras.
- La tornillería y las piezas metálicas están fabricadas en acero inoxidable.
- Las piezas de zamak han sido tratadas para garantizar resistencia a la corrosión de 240 horas en cámara de niebla salina de acuerdo con lo establecido en la norma UNE-EN 1670 (Grado 4).

Kits for tilt & turn windows with CH180+ hinges.

- Maximum sash opening: 180°.
- Maximum load per sash: 100 kg.
- The compatible supplementary corner drives are H122100 and H122100S.

**CH180+ upper hinge**

- Lateral adjustment:  $\pm 3$  mm.
- Tightening adjustment:  $\pm 1$  mm.

**CH180+ lower hinge**

- Vertical adjustment: + 2, - 0,5 mm.
- Lateral adjustment:  $\pm 1,5$  mm.
- Tightening adjustment:  $\pm 0,5$  mm.

**EVO-SOFT hardware**

- The closing effort of the hardware is up to 50% less compared to the use of traditional hardware.
- Possibility of adding multiple locking points.
- All sliding elements are fitted with an anti-looseness clip.
- The screws and metal parts are made of stainless steel.
- The zamak parts have been treated to guarantee 240 hours of corrosion resistance in a saline mist chamber in accordance with the UNE-EN 1670 standard (Grade 4).

**CIERRE AL INVERSOR CON COMPÁS GRANDE**  
LOCKING TO INVERTER WITH LARGE FRICTION STAY

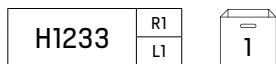

**CIERRE AL MARCO CON COMPÁS GRANDE**  
LOCKING TO FRAME WITH LARGE FRICTION STAY

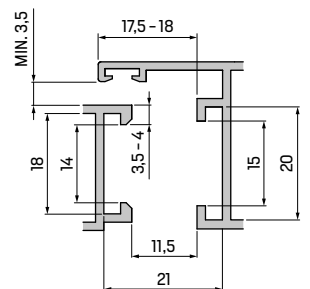
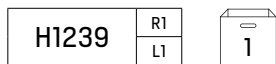

14, 18 CANAL EUROPEO » EJE 10  
EURO GROOVE » TO SHAFT



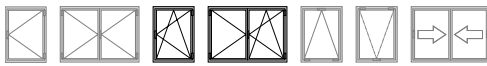

Kits for tilt & turn windows with CH180+ hinges.

- Maximum sash opening: 180°.
- Maximum load per sash: 100 kg.
- The compatible supplementary corner drives are H122100 and H122100S.

#### CH180+ upper hinge

- Lateral adjustment:  $\pm 3$  mm.
- Tightening adjustment:  $\pm 1$  mm.

#### CH180+ lower hinge

- Vertical adjustment: + 2, - 0,5 mm.
- Lateral adjustment:  $\pm 1,5$  mm.
- Tightening adjustment:  $\pm 0,5$  mm.

#### EVO-SOFT hardware

- The closing effort of the hardware is up to 50% less compared to the use of traditional hardware.
- Possibility of adding multiple locking points.
- All sliding elements are fitted with an anti-looseness clip.
- The screws and metal parts are made of stainless steel.
- The zamak parts have been treated to guarantee 240 hours of corrosion resistance in a saline mist chamber in accordance with the UNE-EN 1670 standard (Grade 4).

Kits para ventanas oscilobatientes con bisagras CH180+.

- Apertura máxima de hoja: 180°.
- Carga máxima por hoja: 100 kg.
- Los ángulos de reenvío suplementarios compatibles son: H122100 / H122100S.

#### Bisagra CH180+ superior

- Regulación lateral:  $\pm 3$  mm.
- Regulación de presión:  $\pm 1$  mm.

#### Bisagra CH180+ inferior

- Regulación vertical: + 2, - 0,5 mm.
- Regulación lateral:  $\pm 1,5$  mm.
- Regulación de presión:  $\pm 0,5$  mm.

#### Herraje EVO-SOFT

- El esfuerzo de cierre del herraje es hasta un 50% menor en comparación con el uso de herraje tradicional.
- Posibilidad de añadir múltiples puntos de cierre.
- Todos los elementos deslizantes incorporan un clip antiholguras.
- La tornillería y las piezas metálicas están fabricadas en acero inoxidable.
- Las piezas de zamak han sido tratadas para garantizar resistencia a la corrosión de 240 horas en cámara de niebla salina de acuerdo con lo establecido en la norma UNE-EN 1670 (Grado 4).

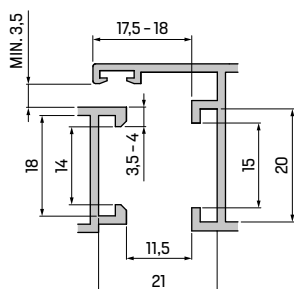

14, 18 CANAL EUROPEO » EJE 10  
EURO GROOVE » 10 SHAFT

### MANIOBRA LÓGICA CON COMPÁS PEQUEÑO TILT-BEFORE-TURN WITH SMALL FRICTION STAY



H1223		R4
		L4



### CIERRE AL INVERSOR CON COMPÁS PEQUEÑO LOCKING TO INVERTER WITH SMALL FRICTION STAY



H1233		R3
		L3



### CIERRE AL MARCO CON COMPÁS PEQUEÑO LOCKING TO FRAME WITH SMALL FRICTION STAY



H1239		R3
		L3



# CLX160kg

Altas cargas y amplio rango de regulaciones

Heavy loads and wide range of adjustments



Perfiles de Canal Europeo  
Euro Groove profiles



Carga máxima de 160 kg  
Maximum load of 160 kg



Bisagras ambidiestras  
Ambidextrous hinges



Regulación tridimensional  
Three-dimensional adjustment

Las bisagras CLX permiten una capacidad de carga de hasta 160 kg por hoja, para ello es imprescindible la instalación del tornillo de estabilización en la pala marco superior. Para el rango de pesos comprendido entre 120 y 160 kg se recomienda el uso de perfil de puerta y la instalación obligatoria del compás CLX con referencia T110301 para maniobra tradicional o con referencia T110304 para maniobra lógica.

## » Regulaciones accesibles

En ventanas de altas cargas se hace necesario que las regulaciones sean simples, efectivas y directas pero sobre todo que sean fiables. Todos los puntos de regulación han sido dispuestos en zonas de fácil acceso y pueden realizarse con la hoja en carga.

## » Seguridad

**Pin de seguridad.** Las bisagras CLX incorporan un pin de seguridad en la zona de contraplaca de la pala-hoja inferior que evita la caída de la hoja en caso de rotura de la contraplaca por golpes fuertes o desplazamientos que afecten al funcionamiento de la bisagra.

**Tornillo estabilizador.** Las bisagras CLX incorporan un tornillo de retención en la zona de la pala-marco superior que evita el desgarro del canal de marco.

The CLX hinges allow a load capacity of up to 160 kg per sash. The installation of the stabilising screw in the upper frame hinge leaf is essential for this. For the weight range between 120 and 160 kg, it is recommended the use of a door profile and the mandatory installation of the CLX friction stay with reference T110301 for traditional operation or with reference T110304 for tilt-before-turn.

## » Accesible adjustments

With highly loaded windows it is essential that the adjustments are simple, effective and direct but above all that they are reliable. All adjustment points are located in easy-to-reach areas and can be regulated with the sash in place.

## » Security

**Security pin.** The CLX hinges incorporate a safety pin in the counterplate area of the lower sash hinge leaf that prevents the sash from falling in the event of breakage of the counterplate due to strong blows or movements that affect the operation of the hinge.

**Stabilising screw.** The CLX hinges incorporate a retaining screw in the upper frame hinge leaf area that prevents the frame groove from tearing.



TORNILLO ESTABILIZADOR  
STABILISING SCREW



PIN DE SEGURIDAD  
SECURITY PIN

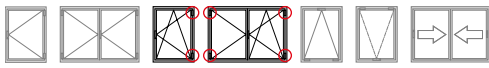

CLX ambidextrous hinge kits specially designed to withstand high loads on tilt & turn windows.

- Maximum load per sash: 160 kg.
- The CLX hinges are supplied pre-assembled for right-handed openings but are ambidextrous, i.e. they include both the left and the right-leaf.
- The CLX ambidextrous hinges have specific tilt & turn friction stays: T110301 and T110304.
- CLX tilt & turn hinges and kits are available in anodised finish, indicating opening hand and with a maximum load per sash of 120 kg.

See anodised CLX hinges and tilt & turn kits in the "Anodised hardware" section.

Kits de bisagras CLX ambidiestras especialmente diseñadas para soportar altas cargas en ventanas oscilobatientes.

- Carga máxima por hoja: 160 kg.
- Las bisagras son suministradas pre-montadas para aperturas a derechas pero son ambidiestras, incluyen tanto la pala izquierda como la derecha.
- Las bisagras CLX ambidiestras disponen de compases oscilobatientes específicos: T110301 y T110304.
- Bisagras y kits oscilobatientes CLX están disponibles en acabado anodizado, indicando mano de apertura y con una carga máxima por hoja de 120 kg.

Ver bisagras y kits oscilobatientes CLX anodizados en la sección « Herraje anodizado ».

**BISAGRAS CLX PARA HOJA ACTIVA**  
CLX HINGES FOR ACTIVE SASH



T1113 \*\*

25



**BISAGRAS CLX PARA HOJA PASIVA**  
CLX HINGES FOR PASSIVE SASH



T1114 \*\*

20



» **REGULACIONES DE LAS BISAGRAS SUPERIORES** UPPER HINGES ADJUSTMENTS

**BISAGRA DE HOJA PASIVA** PASSIVE SASH HINGE

- ALLEN 3 (±3) **REGULACIÓN DE DESCUELGUE** SLIPPING ADJUSTMENT

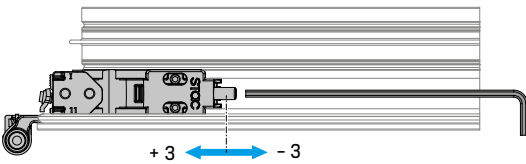

**BISAGRA DE HOJA ACTIVA** ACTIVE SASH HINGE

- ALLEN 4 (±1) **REGULACIÓN DE PRESIÓN** TIGHTENING ADJUSTMENT
- ALLEN 4 (±3) **REGULACIÓN DE DESCUELGUE** SLIPPING ADJUSTMENT

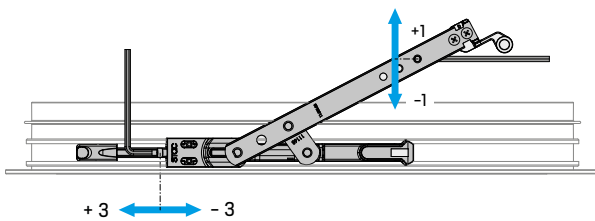

» **REGULACIONES DE LAS BISAGRAS INFERIORES** LOWER HINGES ADJUSTMENTS

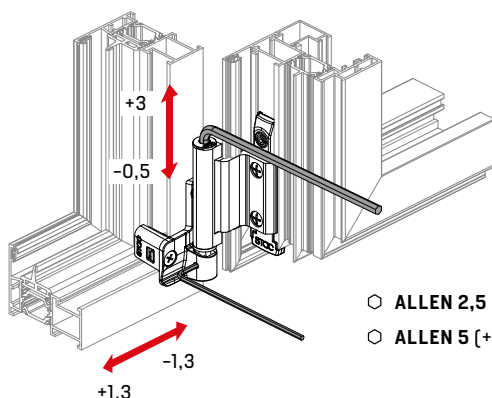

- ALLEN 2,5 (±1,3)
- ALLEN 5 (+3, -0,5)

■ **REGULACIÓN DE PRESIÓN** TIGHTENING ADJUSTMENT **+0,3 mm**

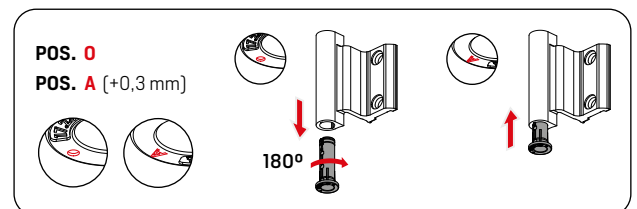

## KIT BASE OSCILOBATIENTE CLX

CLX TILT & TURN BASE KIT

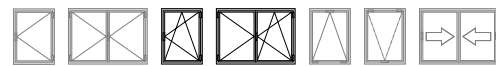

### CIERRE AL INVERSOR SIN CREMONA

LOCKING TO INVERTER WITHOUT CREMONE

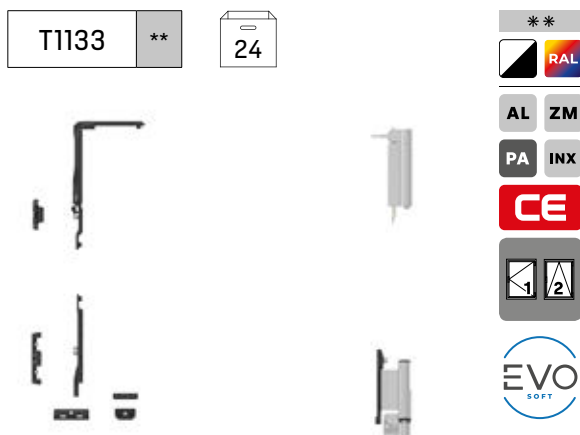

Kits de bisagras ambidiestras CLX para ventanas oscilobatientes.

- Carga máxima por hoja: 160 kg.
- Las bisagras son suministradas pre-montadas para aperturas a derechas pero son ambidiestras, incluyen tanto la pala izquierda como la derecha.
- Están disponibles en acabado anodizado, indicando mano de apertura y con una carga máxima por hoja de 120 kg.

#### Bisagra CLX superior

- Regulación lateral:  $\pm 3$  mm.
- Regulación de presión:  $\pm 1$  mm.

#### Bisagra CLX inferior

- Regulación vertical: + 3, - 0,5 mm.
- Regulación lateral:  $\pm 1,3$  mm.
- Regulación de presión: - 0,3 mm.

#### Herraje EVO-SOFT

- El esfuerzo de cierre del herraje es hasta un 50% menor en comparación con el uso de herraje tradicional.
- Posibilidad de añadir múltiples puntos de cierre.
- Todos los elementos deslizantes incorporan un clip antiholguras.
- La tornillería y las piezas metálicas están fabricadas en acero inoxidable.
- Las piezas de zamak han sido tratadas para garantizar resistencia a la corrosión de 240 horas en cámara de niebla salina de acuerdo con lo establecido en la norma UNE-EN 1670 (Grado 4).

Los compases oscilobatientes no se incluyen en los kits. Consulte los compases compatibles en la página 164.

CLX ambidextrous hinge kits for tilt & turn windows.

- Maximum load per sash: 160 kg.
- The hinges are supplied pre-assembled for right-handed openings but are ambidextrous, i.e. they include both the left and the right-leaf.
- They are available in an anodised finish, indicating opening hand and with a maximum load per sash of 120 kg.

#### CLX upper hinge

- Lateral adjustment:  $\pm 3$  mm.
- Tightening adjustment:  $\pm 1$  mm.

#### CLX lower hinge

- Vertical adjustment: + 3, - 0,5 mm.
- Lateral adjustment:  $\pm 1,3$  mm.
- Tightening adjustment: - 0,3 mm.

#### EVO-SOFT hardware

- The closing effort of the hardware is up to 50% less compared to the use of traditional hardware.
- Possibility of adding multiple locking points.
- All sliding elements are fitted with an anti-looseness clip.
- The screws and metal parts are made of stainless steel.
- The zamak parts have been treated to guarantee 240 hours of corrosion resistance in a saline mist chamber in accordance with the UNE-EN 1670 standard (Grade 4).

The tilt & turn friction stays are not supplied in the kits. See compatible friction stays on page 164.

### CIERRE AL INVERSOR CON CREMONA LYRA O SIRIUS

LOCKING TO INVERTER WITH LYRA OR SIRIUS CREMONE

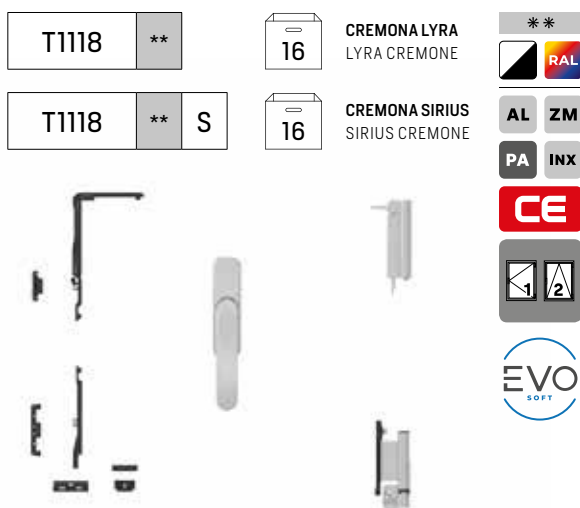

### MANIOBRA LÓGICA SIN CREMONA

TILT -BEFORE-TURN WITHOUT CREMONE

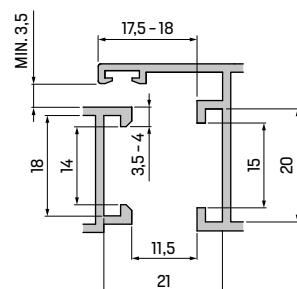
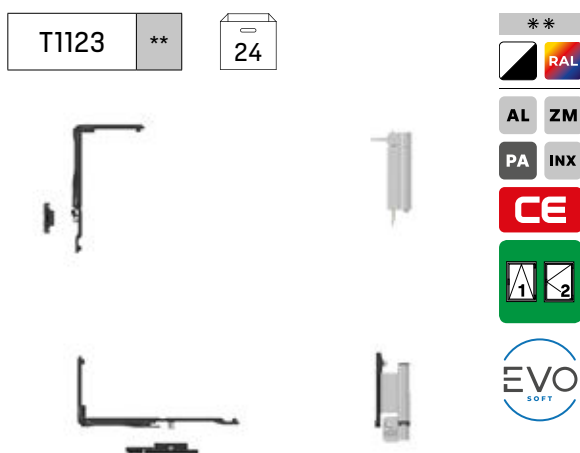

14, 18 CANAL EUROPEO » EJE 10  
EURO GROOVE » TO SHAFT

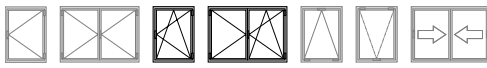

CLX ambidextrous hinge kits for tilt & turn windows.

- Maximum load per sash: 160 kg.
- The hinges are supplied pre-assembled for right-handed openings but are ambidextrous, i.e. they include both the left and the right-leaf.
- They are available in an anodised finish, indicating opening hand and with a maximum load per sash of 120 kg.

#### CLX upper hinge

- Lateral adjustment:  $\pm 3$  mm.
- Tightening adjustment:  $\pm 1$  mm.

#### CLX lower hinge

- Vertical adjustment:  $+ 3, - 0,5$  mm.
- Lateral adjustment:  $\pm 1,3$  mm.
- Tightening adjustment:  $- 0,3$  mm.

#### EVO-SOFT hardware

- The closing effort of the hardware is up to 50% less compared to the use of traditional hardware.
- Possibility of adding multiple locking points.
- All sliding elements are fitted with an anti-looseness clip.
- The screws and metal parts are made of stainless steel.
- The zamak parts have been treated to guarantee 240 hours of corrosion resistance in a saline mist chamber in accordance with the UNE-EN 1670 standard (Grade 4).

The tilt & turn friction stays are not supplied in the kits. See compatible friction stays on page 164.

Kits de bisagras ambidiestras CLX para ventanas oscilobatientes.

- Carga máxima por hoja: 160 kg.
- Las bisagras son suministradas pre-montadas para aperturas a derechas pero son ambidiestras, incluyen tanto la pala izquierda como la derecha.
- Están disponibles en acabado anodizado, indicando mano de apertura y con una carga máxima por hoja de 120 kg.

#### Bisagra CLX superior

- Regulación lateral:  $\pm 3$  mm.
- Regulación de presión:  $\pm 1$  mm.

#### Bisagra CLX inferior

- Regulación vertical:  $+ 3, - 0,5$  mm.
- Regulación lateral:  $\pm 1,3$  mm.
- Regulación de presión:  $- 0,3$  mm.

#### Herraje EVO-SOFT

- El esfuerzo de cierre del herraje es hasta un 50% menor en comparación con el uso de herraje tradicional.
- Posibilidad de añadir múltiples puntos de cierre.
- Todos los elementos deslizantes incorporan un clip antiholguras.
- La tornillería y las piezas metálicas están fabricadas en acero inoxidable.
- Las piezas de zamak han sido tratadas para garantizar resistencia a la corrosión de 240 horas en cámara de niebla salina de acuerdo con lo establecido en la norma UNE-EN 1670 (Grado 4).

Los compases oscilobatientes no se incluyen en los kits. Consulte los compases compatibles en la página 164.

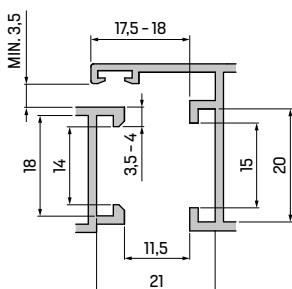

14, 18 CANAL EUROPEO » EJE 10  
EURO GROOVE » 10 SHAFT

### CIERRE AL MARCO SIN CREMONA

LOCKING TO FRAME WITHOUT CREMONE

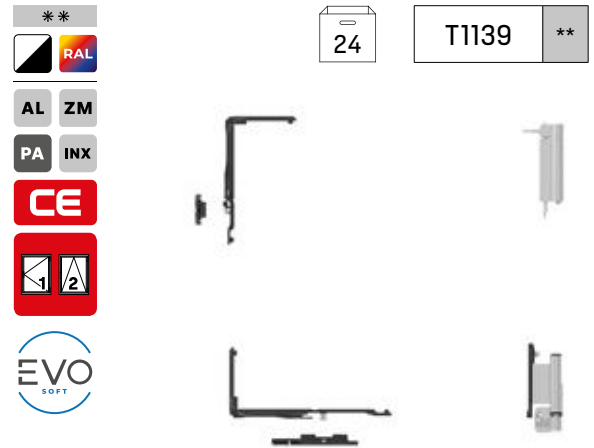

### CIERRE AL MARCO CON CREMONA SIRIUS

LOCKING TO FRAME WITH SIRIUS CREMONE

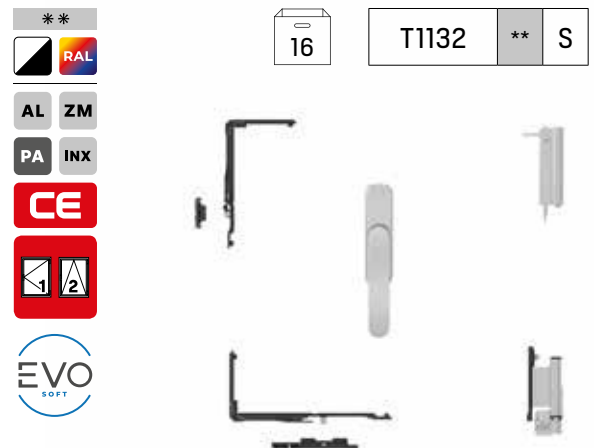

### CIERRE AL MARCO CON HERRAJE EVO-SECURITY

LOCKING TO FRAME WITH EVO-SECURITY HARDWARE

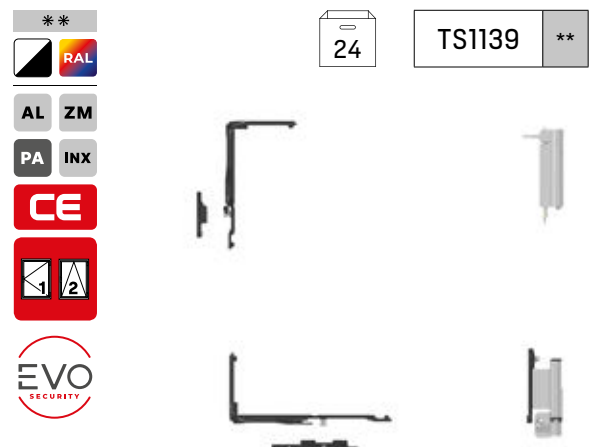



# CLASSIC

hasta 120 kg por hoja up to 120 kg per sash



**Perfiles de Canal Europeo**  
Euro Groove profiles



**Carga máxima de 120 kg**  
Maximum load of 120 kg



**Bisagras ambidiestras**  
Ambidextrous hinges



**UNE-EN 1670: Grado 4**  
UNE-EN 1670: Grade 4

Las bisagras CLASSIC para perfiles con Canal Europeo han sido diseñadas y desarrolladas para ajustarse a las tipologías de ventanas más habituales en el mercado del cerramiento en aluminio y son compatibles con todos los elementos oscilobatientes tradicionales de STAC.

Las bisagras CLASSIC disponen de un tornillo de fijación al marco que reduce de forma considerable los esfuerzos a fatiga y la pala hoja es compatible con pasos de bisagra desde 3 mm.

#### » Carga máxima de 120 kg

Las bisagras oscilobatientes CLASSIC permite configuraciones de ventana de hasta 120 kg por hoja. Asimismo, la ubicación de la ventana o la altura de colocación de la cremone puede variar las configuraciones recomendadas. A partir de 1000 mm de alto o ancho y 80 kg de peso se recomienda que el perfil usado sea de puerta balconera.

#### » Bisagras ambidiestras

Las bisagras CLASSIC son ambidiestras, es decir, no guardan mano de apertura de la ventana. Las bisagras de hoja tienen el eje de la bisagra inferior insertado ya de fábrica en la pala de hoja. Por defecto, las bisagras están premontadas a derechas y son fácilmente intercambiables a izquierdas.

#### » Resistencia a la corrosión

Las piezas de zamak han sido tratadas para garantizar una resistencia a la corrosión superior a las 240 horas en Cámara de Niebla Salina (CNS) en cumplimiento con la norma UNE-EN 1670 obteniendo una clasificación de grado 4 que otorga una alta resistencia a la corrosión y la posibilidad de uso en entornos con condiciones climáticas severas.

The CLASSIC hinges for European Groove profiles have been designed and developed to fit the most common types of windows in the aluminium enclosure market and are compatible with all traditional STAC tilt & turn elements.

The CLASSIC hinges have a frame fixing screw that considerably reduces fatigue stresses and the sash leaf is compatible with hinge pitches from 3 mm.

#### » Maximum load of 120 kg

CLASSIC tilt & turn hinges allow window configurations up to 120 kg per sash. In addition, the location of the window or the height of the cremone may vary the recommended configurations. From 1000 mm in height or width and 80 kg in weight, it is recommended that the profile used is a balcony door profile.

#### » Ambidextrous hinges

CLASSIC hinges are ambidextrous, i.e. they do not keep the opening hand of the window. The sash hinges have the lower hinge axis already inserted into the sash leaf at the factory. By default, the hinges are pre-assembled on the right-hand side and are easily interchangeable on the left-hand side.

#### » Corrosion resistance

The zamak parts have been treated to ensure a corrosion resistance of more than 240 hours in Saline Mist Chamber (SMC) in compliance with UNE-EN 1670 obtaining a grade 4 rating that gives high corrosion resistance and usability in environments with severe weather conditions.



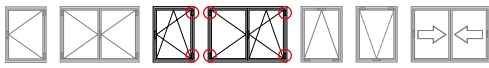

CLASSIC adjustable hinge kits for tilt & turn windows.

- Maximum load per sash: 120 kg.
- The hinges are supplied pre-assembled for right-hand opening.
- The hinges for the passive sash are compatible with the adjustable top hinge adapter with reference T110100.

**CLASSIC upper hinge**

- Lateral adjustment:  $\pm 3$  mm.
- Tightening adjustment:  $\pm 1$  mm.

**CLASSIC lower hinge**

- Vertical adjustment:  $+3, -0,5$  mm.
- Lateral adjustment:  $\pm 1,5$  mm.

Kits de bisagras regulables CLASSIC para ventanas oscilobatientes.

- Carga máxima por hoja: 120 kg.
- Las bisagras se suministran premontadas para apertura a derechas.
- Las bisagras para hoja pasiva son compatibles con el falso compás regulable con referencia T110100.

**Bisagra CLASSIC superior**

- Regulación lateral:  $\pm 3$  mm.
- Regulación de presión:  $\pm 1$  mm.

**Bisagra CLASSIC inferior**

- Regulación vertical:  $+3, -0,5$  mm.
- Regulación lateral:  $\pm 1,5$  mm.

**BISAGRAS CLASSIC PARA HOJA ACTIVA**  
CLASSIC HINGES FOR ACTIVE SASH



25

B1113 \*\*



» **REGULACIONES DE LAS BISAGRAS SUPERIORES** UPPER HINGES ADJUSTMENTS

**BISAGRA DE HOJA PASIVA** PASSIVE SASH HINGE

- ALLEN 3 ( $\pm 3$ ) **REGULACIÓN DE DESCUELQUE** SLIPPING ADJUSTMENT

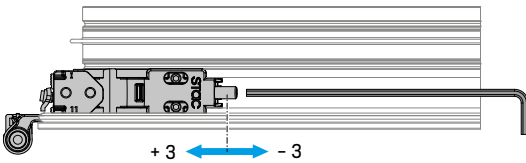

**BISAGRA DE HOJA ACTIVA** ACTIVE SASH HINGE

- ALLEN 4 ( $\pm 1$ ) **REGULACIÓN DE PRESIÓN** TIGHTENING ADJUSTMENT
- ALLEN 4 ( $\pm 3$ ) **REGULACIÓN DE DESCUELQUE** SLIPPING ADJUSTMENT

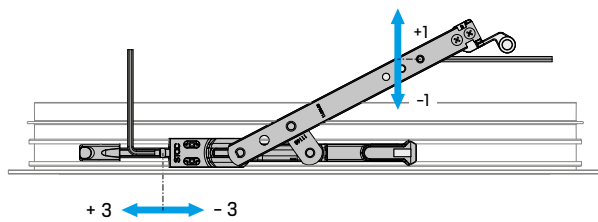

**BISAGRAS CLASSIC PARA HOJA PASIVA**  
CLASSIC HINGES FOR PASSIVE SASH



20

B1114 \*\*



» **REGULACIONES DE LAS BISAGRAS INFERIORES** LOWER HINGES ADJUSTMENTS

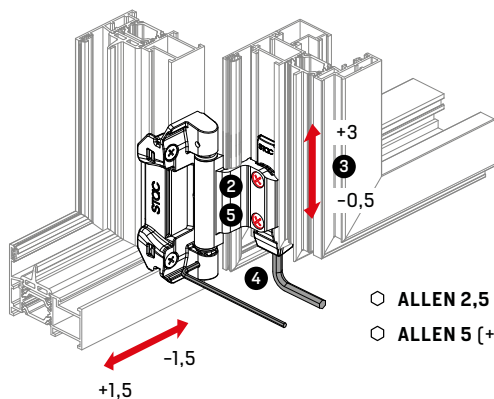

- ALLEN 2,5 ( $\pm 1,5$ )
- ALLEN 5 ( $+3, -0,5$ )

**REGULACIÓN EN ALTURA** HEIGHT ADJUSTMENT  $+3, -0,5$  mm

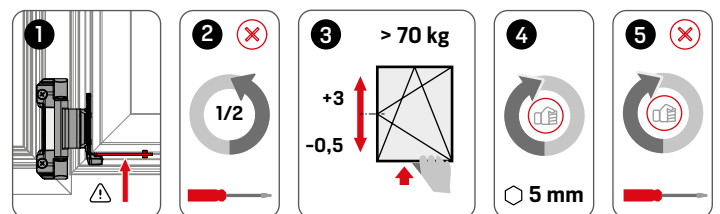

## KIT BASE OSCILOBATIENTE CLASSIC

CLASSIC TILT & TURN BASE KIT

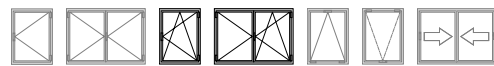

### CIERRE AL INVERSOR SIN CREMONA

LOCKING TO INVERTER WITHOUT CREMONE

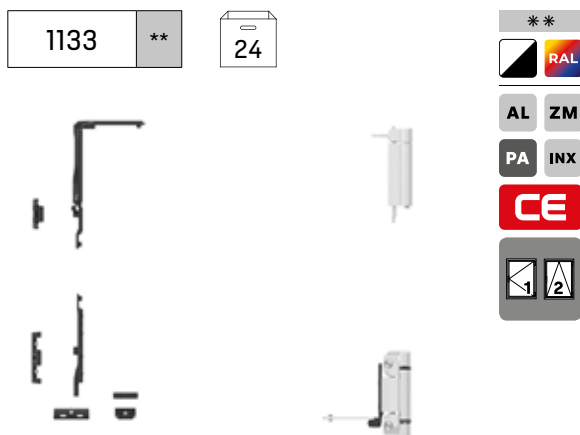

### CIERRE AL INVERSOR CON CREMONA LYRA

LOCKING TO INVERTER WITH LYRA CREMONE

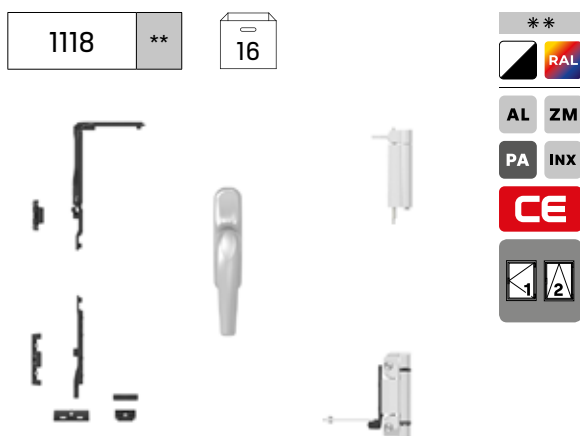

### CIERRE AL INVERSOR CON CREMONA SIRIUS

LOCKING TO INVERTER WITH SIRIUS CREMONE

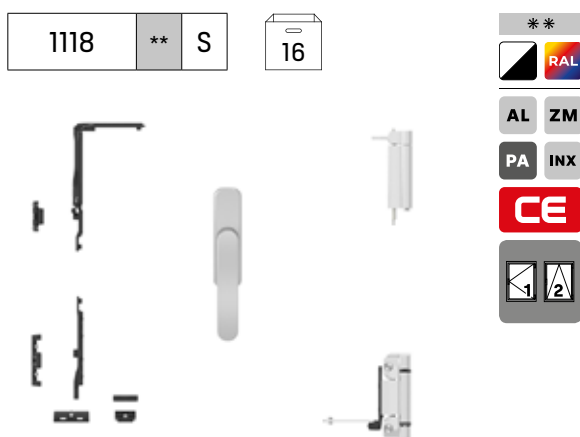

Kits para ventanas oscilobatientes con bisagras regulables CLASSIC.

- Carga máxima por hoja: 120 kg.
- Las bisagras se suministran premontadas para apertura a derechas.
- Los kits se suministran con puntos de cierre regulables.

#### Bisagra CLASSIC superior

- Regulación lateral:  $\pm 3$  mm.
- Regulación de presión:  $\pm 1$  mm.

#### Bisagra CLASSIC inferior

- Regulación vertical:  $+ 3, - 0,5$  mm.
- Regulación lateral:  $\pm 1,3$  mm.
- Regulación de presión:  $- 0,3$  mm.

Los compases oscilobatientes no se incluyen en los kits. Consulte los compases compatibles en la página 164.

Kits for tilt & turn windows with CLASSIC adjustable hinges.

- Maximum load per sash: 120 kg.
- The hinges are supplied pre-assembled for right-hand opening.
- The kits are supplied with adjustable locking points.

#### CLASSIC upper hinge

- Lateral adjustment:  $\pm 3$  mm.
- Tightening adjustment:  $\pm 1$  mm.

#### CLASSIC lower hinge

- Vertical adjustment:  $+ 3, - 0,5$  mm.
- Lateral adjustment:  $\pm 1,3$  mm.
- Tightening adjustment:  $- 0,3$  mm.

The tilt & turn friction stays are not supplied in the kits. See compatible friction stays on page 164.

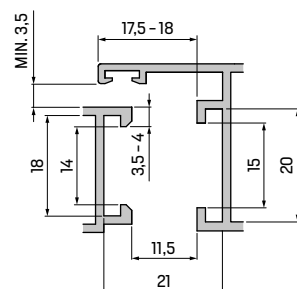

14, 18 CANAL EUROPEO » EJE 10  
EURO GROOVE » TO SHAFT



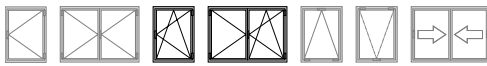

Kits for tilt & turn windows with CLASSIC adjustable hinges.

- Maximum load per sash: 120 kg.
- The hinges are supplied pre-assembled for right-hand opening.
- The kits are supplied with adjustable locking points.

**CLASSIC upper hinge**

- Lateral adjustment:  $\pm 3$  mm.
- Tightening adjustment:  $\pm 1$  mm.

**CLASSIC lower hinge**

- Vertical adjustment:  $+3, -0,5$  mm.
- Lateral adjustment:  $\pm 1,3$  mm.
- Tightening adjustment:  $-0,3$  mm.

The tilt & turn friction stays are not supplied in the kits. See compatible friction stays on page 164.

Kits para ventanas oscilobatientes con bisagras regulables CLASSIC.

- Carga máxima por hoja: 120 kg.
- Las bisagras se suministran premontadas para apertura a derechas.
- Los kits se suministran con puntos de cierre regulables.

**Bisagra CLASSIC superior**

- Regulación lateral:  $\pm 3$  mm.
- Regulación de presión:  $\pm 1$  mm.

**Bisagra CLASSIC inferior**

- Regulación vertical:  $+3, -0,5$  mm.
- Regulación lateral:  $\pm 1,3$  mm.
- Regulación de presión:  $-0,3$  mm.

Los compases oscilobatientes no se incluyen en los kits. Consulte los compases compatibles en la página 164.

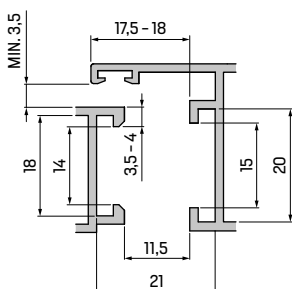

14, 18 CANAL EUROPEO » EJE 10  
EURO GROOVE » 10 SHAFT

**CIERRE AL MARCO SIN CREMONA**  
LOCKING TO FRAME WITHOUT CREMONE

\*\*

RAL

AL ZM

PA INX

CE

1/2

24

1139

\*\*

**CIERRE AL MARCO CON CREMONA LYRA**  
LOCKING TO FRAME WITH LYRA CREMONE

\*\*

RAL

AL ZM

PA INX

CE

1/2

16

1132

\*\*

**CIERRE AL MARCO CON CREMONA SIRIUS**  
LOCKING TO FRAME WITH SIRIUS CREMONE

\*\*

RAL

AL ZM

PA INX

CE

1/2

16

1132

\*\* S

## KIT BASE OSCILOBATIENTE CLASSIC

CLASSIC TILT & TURN BASE KIT

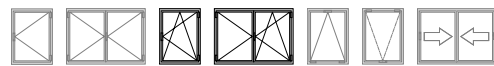

### MANIOBRA LÓGICA SIN CREMONA

TILT-BEFORE-TURN WITHOUT CREMONE

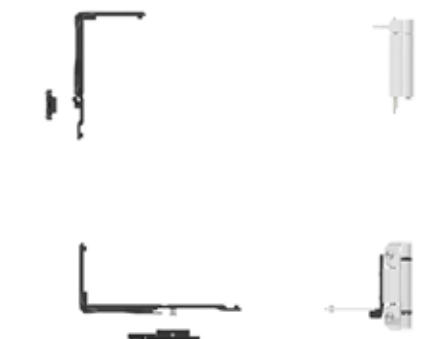
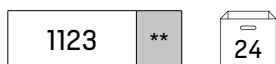

Kits para ventanas oscilobatientes con bisagras regulables CLASSIC.

- Carga máxima por hoja: 120 kg.
- Las bisagras se suministran premontadas para apertura a derechas.
- Los kits se suministran con puntos de cierre regulables.

#### Bisagra CLASSIC superior

- Regulación lateral:  $\pm 3$  mm.
- Regulación de presión:  $\pm 1$  mm.

#### Bisagra CLASSIC inferior

- Regulación vertical: + 3, - 0,5 mm.
- Regulación lateral:  $\pm 1,3$  mm.
- Regulación de presión: - 0,3 mm.

Los compases oscilobatientes no se incluyen en los kits. Consulte los compases compatibles en la página 164.

Kits for tilt & turn windows with CLASSIC adjustable hinges.

- Maximum load per sash: 120 kg.
- The hinges are supplied pre-assembled for right-hand opening.
- The kits are supplied with adjustable locking points.

#### CLASSIC upper hinge

- Lateral adjustment:  $\pm 3$  mm.
- Tightening adjustment:  $\pm 1$  mm.

#### CLASSIC lower hinge

- Vertical adjustment: + 3, - 0,5 mm.
- Lateral adjustment:  $\pm 1,3$  mm.
- Tightening adjustment: - 0,3 mm.

The tilt & turn friction stays are not supplied in the kits. See compatible friction stays on page 164.

### MANIOBRA LÓGICA + CREMONA CON LLAVE

TILT-BEFORE-TURN + CREMONE WITH KEY

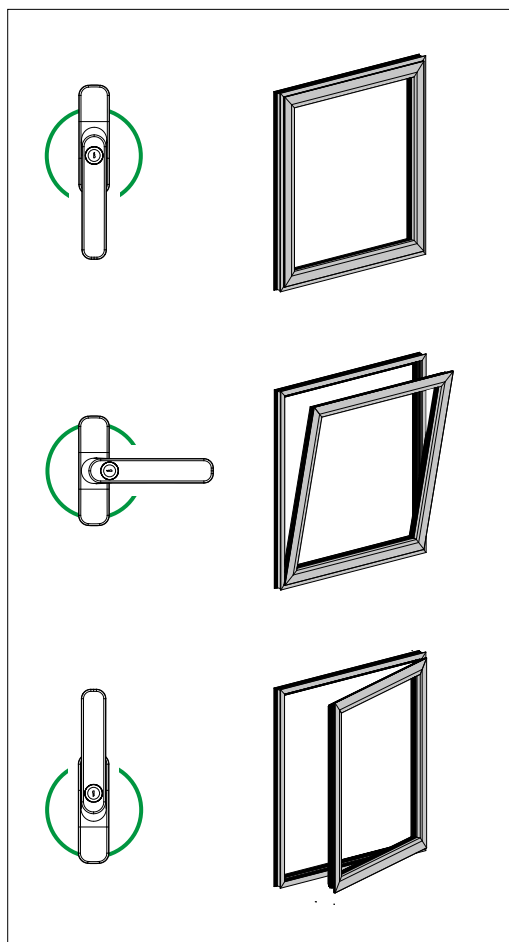

Cremonas compatibles Compatible cremones  
SIRIUS BLOCK / LYRA BLOCK

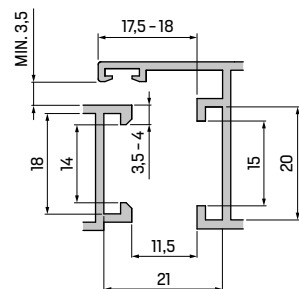

14, 18 CANAL EUROPEO » EJE 10  
EURO GROOVE » TO SHAFT

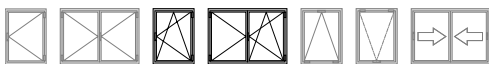

**CIERRE AL INVERSOR CLASSIC**  
CLASSIC LOCKING TO THE INVERTER



**CIERRE AL MARCO CLASSIC**  
CLASSIC LOCKING TO FRAME

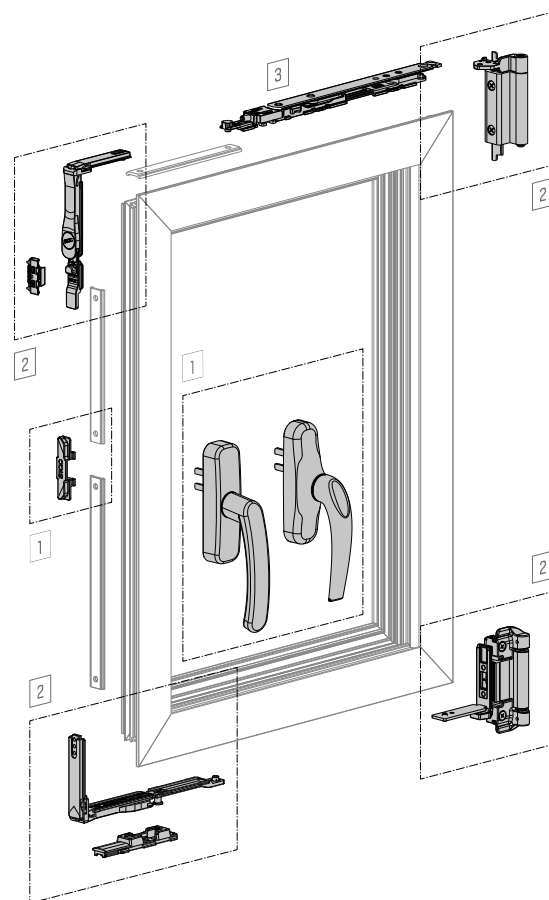
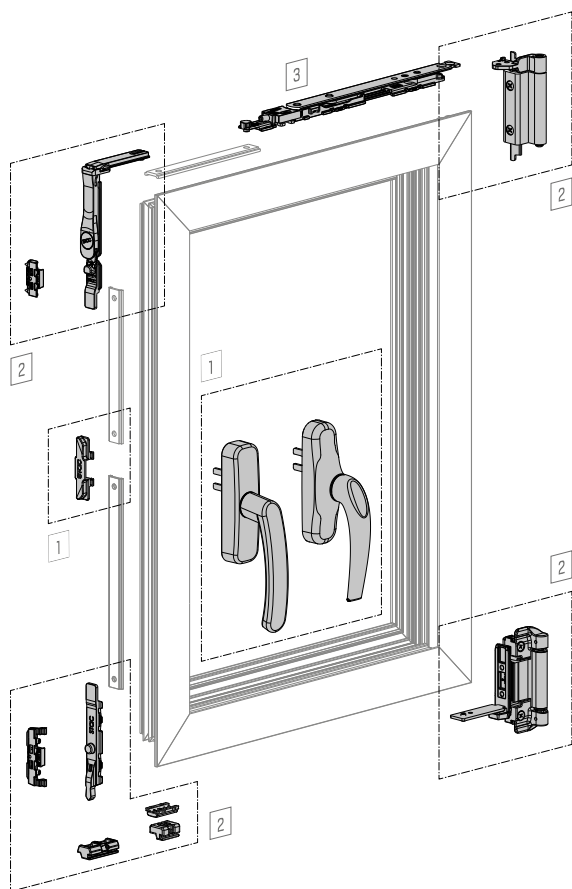

**KIT OSCIOBATIENTE CLASSIC CIERRE AL INVERSOR**

CLASSIC TILT & TURN KIT LOCKING TO INVERTER



1	<b>CREMONA</b> Ver la sección de « Manillas y cremonas » CREMONE See the chapter on « Handles and cremones »	
2	<b>1133</b> ** <b>KIT CIERRE AL INVERSOR SIN CREMONA</b> LOCKING TO INVERTER KIT WITHOUT CREMONE	1
3	<b>COMPÁS OSCIOBATIENTE</b> Ver compases en página 164 TILT & TURN FRICTION STAY See friction stays on page 164	10

**KIT OSCIOBATIENTE CLASSIC CIERRE AL MARCO**

CLASSIC TILT & TURN KIT LOCKING TO FRAME



1	<b>CREMONA</b> Ver la sección de « Manillas y cremonas » CREMONE See the chapter on « Handles and cremones »	
2	<b>1139</b> ** <b>KIT CIERRE AL MARCO SIN CREMONA</b> LOCKING TO FRAME KIT WITHOUT CREMONE	1
3	<b>1123</b> ** <b>KIT MANIOBRA LÓGICA SIN CREMONA</b> TILT-BEFORE-TURN KIT WITHOUT CREMONE	
3	<b>COMPÁS OSCIOBATIENTE</b> Ver compases en página 164 TILT & TURN FRICTION STAY See friction stays on page 164	10

■ **TROQUELADO DE LA FALLEBA DE TRANSMISIÓN** TRANSMISSION ROD MACHINING

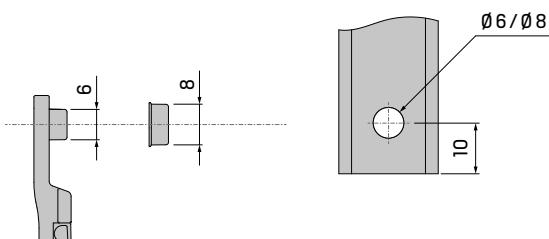

\* El herraje que se especifica en estas configuraciones es para ventanas oscilobatientes con un máximo 1200 x 1200 mm. Para otras medidas de ventana consulte el Catálogo Técnico.

The hardware specified in these configurations is for tilt & turn windows with a maximum of 1200 x 1200 mm. For other window sizes, please refer to the Technical Catalogue.



# smart

**Herraje optimizado** Optimised hardware



**Perfiles de Canal Europeo**  
Euro Groove profiles



**Herraje EVO-SOFT**  
EVO-SOFT hardware



**Bisagras ambidiestras**  
Ambidextrous hinges



**Regulación tridimensional**  
Three-dimensional adjustment

Las bisagras SMART para perfiles con Canal Europeo han sido diseñadas y desarrolladas para ajustarse a las tipologías de ventanas más habituales en el mercado del cerramiento en aluminio. Con este herraje compatible con todos los elementos oscilobatientes tradicionales de STAC, los clientes disponen de una solución competitiva y con mayores prestaciones para las ventanas del día a día.

Las bisagras SMART han superado con resultado satisfactorio todos los ensayos realizados por el laboratorio TECNALIA según lo descrito en norma UNE-EN 13126-8: 2018, "Requisitos y métodos de ensayo para herrajes oscilobatientes, batiente oscilantes y de apertura batiente".

#### » La suavidad de cierre

Todos los sistemas oscilobatientes SMART incluyen puntos de cierre encasquillados EVO-SOFT. El herraje con casquillos permite prolongar la durabilidad de los cerraderos y reducir el desgaste por rozamiento, a la vez que facilita una mayor suavidad en el cierre de las ventanas.

#### » Bisagras ambidiestras

Las bisagras SMART son ambidiestras, es decir, no guardan mano de apertura de la ventana, simplificando de esta forma la gestión de los pedidos y reduciendo el stock de forma considerable.

#### » Regulación tridimensional

En las ventanas se hace necesario que las regulaciones sean simples, efectivas y directas, pero sobre todo que sean fiables. La bisagra inferior SMART permite realizar regulación tridimensional (regulaciones en altura, lateral y de presión).

SMART tilt & turn hinges for Euro Groove profiles have been designed and developed to fit the most common window types in the aluminium window market. With this hardware that is fully compatible with all the traditional tilt and turn elements developed by STAC, customers have a competitive and high-performance solution for everyday windows.

The SMART hinges have passed with satisfactory results all the tests carried out by the TECNALIA test laboratory as described in the UNE-EN 13126-8: 2018 standard, "Requirements and test methods for tilt & turn, tilt-first and turn-only hardware".

#### » Smooth closing

All SMART tilt & turn systems include EVO-SOFT encased locking points which is why the hardware with bushings in the locking points prolongs the durability of the keepers and reduces wear and tear due to friction, while facilitating smoother closing of the windows.

#### » Ambidextrous hinges

SMART hinges are ambidextrous, i.e. they do not keep the window opening hand, thus simplifying order management and considerably reducing stock.

#### » Three-dimensional adjustment

In windows, simple, effective and straightforward adjustments are necessary, but above all they must be reliable. The SMART bottom hinge allows three-dimensional adjustment (height, lateral and pressure adjustment).

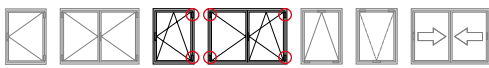

SMART hinge kits for windows with tilt & turn opening.

- Maximum load per sash: 90 kg.
- Reversible: the same hinges are valid for both the active and passive sash.
- The hinges are supplied with counter plates made of zamak.

**SMART upper hinge**

- Lateral adjustment:  $\pm 3$  mm.
- Tightening adjustment:  $\pm 1$  mm.

**SMART lower hinge**

- Vertical adjustment:  $+ 2,5, - 0,5$  mm.
- Lateral adjustment:  $\pm 1,5$  mm.
- Tightening adjustment:  $+ 0,5$  mm.

Kits de bisagras SMART para ventanas con apertura oscilobatiente.

- Carga máxima por hoja: 90 kg.
- Reversibles: las mismas bisagras son válidas para la hoja activa como pasiva.
- Las bisagras se suministran con contraplacas fabricadas en zamak.

**Bisagra SMART superior**

- Regulación lateral:  $\pm 3$  mm.
- Regulación de presión:  $\pm 1$  mm.

**Bisagra SMART inferior**

- Regulación vertical:  $+ 2,5, - 0,5$  mm.
- Regulación lateral:  $\pm 1,5$  mm.
- Regulación de presión:  $+ 0,5$  mm.

**BISAGRAS SMART PARA HOJA ACTIVA**  
SMART HINGES FOR ACTIVE SASH



R1113 \*\*

25



» **REGULACIONES DE LAS BISAGRAS SUPERIORES** UPPER HINGES ADJUSTMENTS

**BISAGRA DE HOJA PASIVA** PASSIVE SASH HINGE

- ALLEN 3 ( $\pm 3$ ) **REGULACIÓN DE DESCUELQUE** SLIPPING ADJUSTMENT

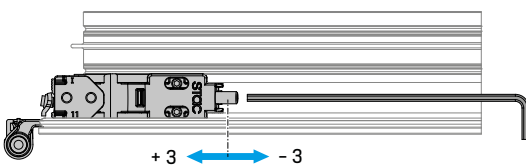

**BISAGRA DE HOJA ACTIVA** ACTIVE SASH HINGE

- ALLEN 4 ( $\pm 1$ ) **REGULACIÓN DE PRESIÓN** TIGHTENING ADJUSTMENT
- ALLEN 4 ( $\pm 3$ ) **REGULACIÓN DE DESCUELQUE** SLIPPING ADJUSTMENT

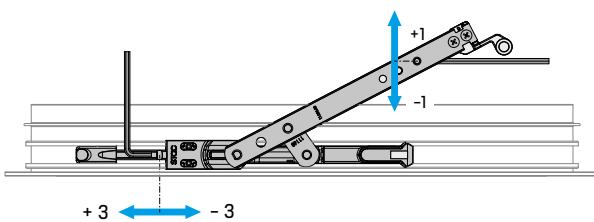

» **REGULACIONES DE LAS BISAGRAS INFERIORES** LOWER HINGES ADJUSTMENTS

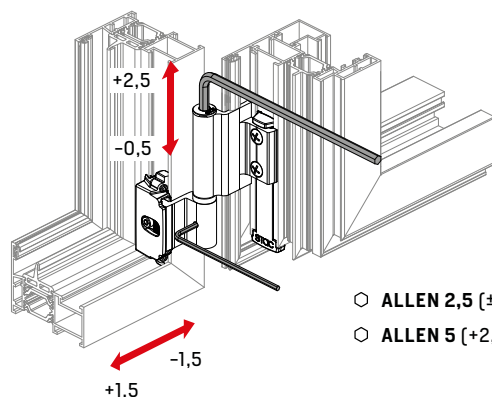

- ALLEN 2,5 ( $\pm 1,5$ )
- ALLEN 5 ( $+2,5, -0,5$ )

**BISAGRAS SMART PARA HOJA PASIVA**  
SMART HINGES FOR PASSIVE SASH



R1114 \*\*

20



**REGULACIÓN DE PRESIÓN** TIGHTENING ADJUSTMENT

PRESIÓN TIGHTENING	PESO DE HOJA SASH WEIGHT	CASQUILLO BUSHING
0	< 60 kg	0
0,5	60 – 90 kg	1(+180)

Por defecto, las bisagras se suministran con ajuste de presión 0.  
By default, the hinges are supplied with pressure setting 0.

■ **REGULACIÓN DE PRESIÓN** TIGHTENING ADJUSTMENT **+0,5 mm**

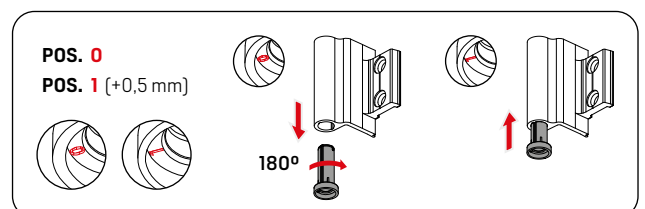

## KIT BASE OSCILOBATIENTE SMART

SMART TILT & TURN BASE KIT

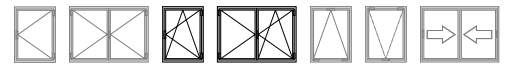

### CIERRE AL INVERSOR SIN CREMONA

LOCKING TO INVERTER WITHOUT CREMONE

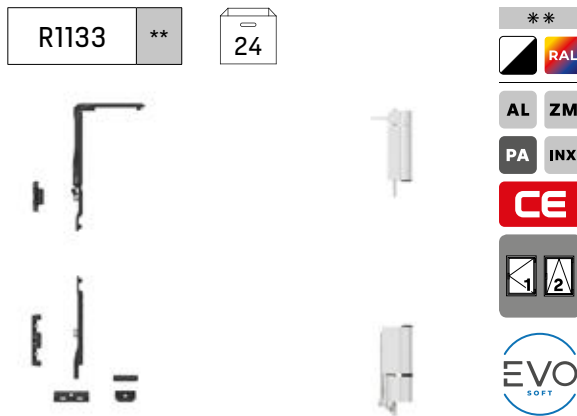

### CIERRE AL INVERSOR CON CREMONA LYRA

LOCKING TO INVERTER WITH LYRA CREMONE

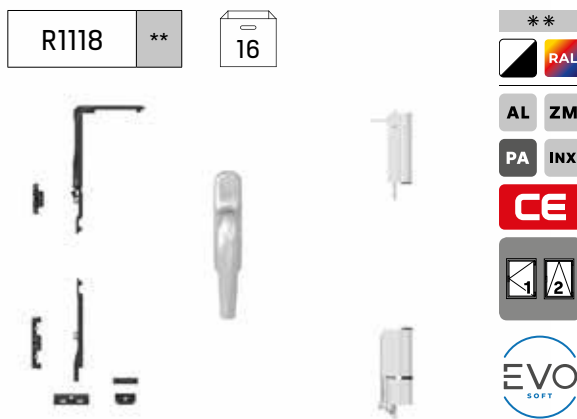

### CIERRE AL INVERSOR CON CREMONA SIRIUS

LOCKING TO INVERTER WITH SIRIUS CREMONE

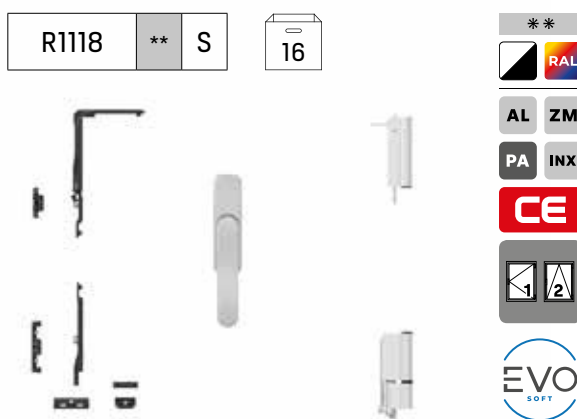

Kits para ventanas oscilobatientes con bisagras regulables SMART.

- Carga máxima por hoja: 90 kg.
- Los kits se suministran con puntos de cierre encasquillados y regulables.

#### Bisagra SMART superior

- Regulación lateral:  $\pm 3$  mm.
- Regulación de presión:  $\pm 1$  mm.

#### Bisagra SMART inferior

- Regulación vertical:  $+ 2,5, - 0,5$  mm.
- Regulación lateral:  $\pm 1,5$  mm.
- Regulación de presión:  $+ 0,5$  mm.

#### Herraje EVO-SOFT

- El esfuerzo de cierre del herraje es hasta un 50% menor en comparación con el uso de herraje tradicional.
- Posibilidad de añadir múltiples puntos de cierre.
- Todos los elementos deslizantes incorporan un clip antiholguras.
- La tornillería y las piezas metálicas están fabricadas en acero inoxidable.
- Las piezas de zamak han sido tratadas para garantizar resistencia a la corrosión de 240 horas en cámara de niebla salina de acuerdo con lo establecido en la norma UNE-EN 1670 (Grado 4).

Los compases oscilobatientes no se incluyen en los kits. Consulte los compases compatibles en la página 164.

Kits for tilt & turn windows with SMART adjustable hinges.

- Maximum load per sash: 90 kg.
- The kits are supplied with encased and adjustable locking points.

#### SMART upper hinge

- Lateral adjustment:  $\pm 3$  mm.
- Tightening adjustment:  $\pm 1$  mm.

#### SMART lower hinge

- Vertical adjustment:  $+ 2,5, - 0,5$  mm.
- Lateral adjustment:  $\pm 1,5$  mm.
- Tightening adjustment:  $+ 0,5$  mm.

#### EVO-SOFT hardware

- The closing effort of the hardware is up to 50% less compared to the use of traditional hardware.
- Possibility of adding multiple locking points.
- All sliding elements are fitted with an anti-looseness clip.
- The screws and metal parts are made of stainless steel.
- The zamak parts have been treated to guarantee 240 hours of corrosion resistance in a saline mist chamber in accordance with the UNE-EN 1670 standard (Grade 4).

The tilt & turn friction stays are not supplied in the kits. See compatible friction stays on page 164.

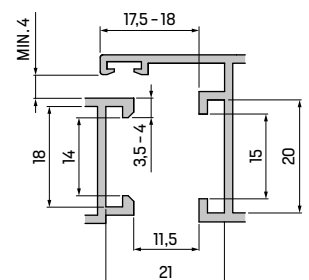

14, 18 CANAL EUROPEO » EJE 10  
EURO GROOVE » TO SHAFT

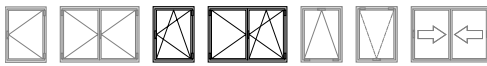

Kits for tilt & turn windows with SMART adjustable hinges.

- Maximum load per sash: 90 kg.
- The kits are supplied with encased and adjustable locking points, except for the lower corner drive with EVO-SECURITY mushroom locking point.

#### SMART upper hinge

- Lateral adjustment:  $\pm 3$  mm.
- Tightening adjustment:  $\pm 1$  mm.

#### SMART lower hinge

- Vertical adjustment:  $+ 2,5, - 0,5$  mm.
- Lateral adjustment:  $\pm 1,5$  mm.
- Tightening adjustment:  $+ 0,5$  mm.

#### EVO-SOFT hardware

- The closing effort of the hardware is up to 50% less compared to the use of traditional hardware.
- Possibility of adding multiple locking points.
- All sliding elements are fitted with an anti-looseness clip.
- The screws and metal parts are made of stainless steel.
- The zamak parts have been treated to guarantee 240 hours of corrosion resistance in a saline mist chamber in accordance with the UNE-EN 1670 standard (Grade 4).

The tilt & turn friction stays are not supplied in the kits. See compatible friction stays on page 164.

Kits para ventanas oscilobatientes con bisagras regulables SMART.

- Carga máxima por hoja: 90 kg.
- Los kits se suministran con puntos de cierre encasquillados y regulables, excepto el ángulo de reenvío inferior con seta de seguridad EVO-SECURITY.

#### Bisagra SMART superior

- Regulación lateral:  $\pm 3$  mm.
- Regulación de presión:  $\pm 1$  mm.

#### Bisagra SMART inferior

- Regulación vertical:  $+ 2,5, - 0,5$  mm.
- Regulación lateral:  $\pm 1,5$  mm.
- Regulación de presión:  $+ 0,5$  mm.

#### Herraje EVO-SOFT

- El esfuerzo de cierre del herraje es hasta un 50% menor en comparación con el uso de herraje tradicional.
- Posibilidad de añadir múltiples puntos de cierre.
- Todos los elementos deslizantes incorporan un clip antiholguras.
- La tornillería y las piezas metálicas están fabricadas en acero inoxidable.
- Las piezas de zamak han sido tratadas para garantizar resistencia a la corrosión de 240 horas en cámara de niebla salina de acuerdo con lo establecido en la norma UNE-EN 1670 (Grado 4).

Los compases oscilobatientes no se incluyen en los kits. Consulte los compases compatibles en la página 164.

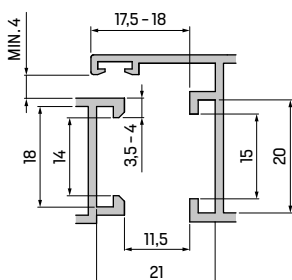

14, 18 CANAL EUROPEO » EJE 10  
EURO GROOVE » 10 SHAFT

### CIERRE AL MARCO SIN CREMONA

LOCKING TO FRAME WITHOUT CREMONE

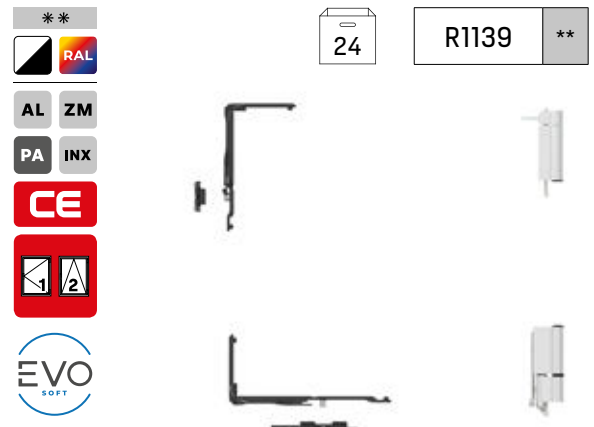

### CIERRE AL MARCO CON CREMONA LYRA

LOCKING TO FRAME WITH LYRA CREMONE

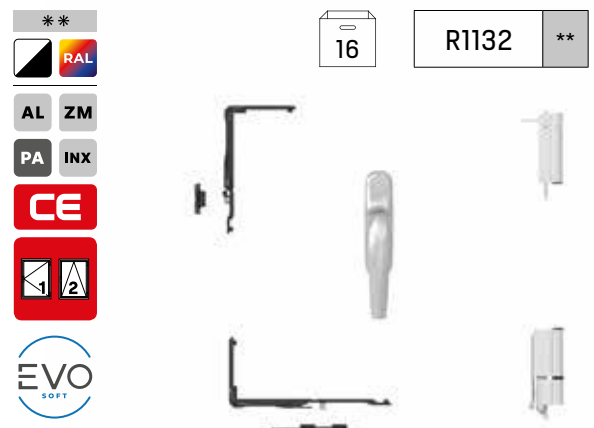

### CIERRE AL MARCO CON CREMONA SIRIUS

LOCKING TO FRAME WITH SIRIUS CREMONE





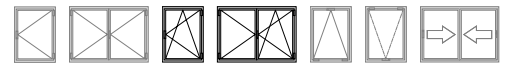

**MANIOBRA LÓGICA SIN CREMONA**  
TILT-BEFORE-TURN WITHOUT CREMONE

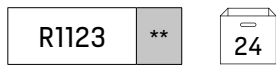

Kits para ventanas oscilobatientes con bisagras regulables SMART.

- Carga máxima por hoja: 90 kg.
- Los kits se suministran con puntos de cierre encasquillados y regulables.

**Bisagra SMART superior**

- Regulación lateral:  $\pm 3$  mm.
- Regulación de presión:  $\pm 1$  mm.

**Bisagra SMART inferior**

- Regulación vertical:  $+ 2,5, - 0,5$  mm.
- Regulación lateral:  $\pm 1,5$  mm.
- Regulación de presión:  $+ 0,5$  mm.

**Herraje EVO-SOFT**

- El esfuerzo de cierre del herraje es hasta un 50% menor en comparación con el uso de herraje tradicional.
- Posibilidad de añadir múltiples puntos de cierre.
- Todos los elementos deslizantes incorporan un clip antiholguras.
- La tornillería y las piezas metálicas están fabricadas en acero inoxidable.
- Las piezas de zamak han sido tratadas para garantizar resistencia a la corrosión de 240 horas en cámara de niebla salina de acuerdo con lo establecido en la norma UNE-EN 1670 (Grado 4).

Los compases oscilobatientes no se incluyen en los kits. Consulte los compases compatibles en la página 164.

Kits for tilt & turn windows with SMART adjustable hinges.

- Maximum load per sash: 90 kg.
- The kits are supplied with encased and adjustable locking points.

**SMART upper hinge**

- Lateral adjustment:  $\pm 3$  mm.
- Tightening adjustment:  $\pm 1$  mm.

**SMART lower hinge**

- Vertical adjustment:  $+ 2,5, - 0,5$  mm.
- Lateral adjustment:  $\pm 1,5$  mm.
- Tightening adjustment:  $+ 0,5$  mm.

**EVO-SOFT hardware**

- The closing effort of the hardware is up to 50% less compared to the use of traditional hardware.
- Possibility of adding multiple locking points.
- All sliding elements are fitted with an anti-looseness clip.
- The screws and metal parts are made of stainless steel.
- The zamak parts have been treated to guarantee 240 hours of corrosion resistance in a saline mist chamber in accordance with the UNE-EN 1670 standard (Grade 4).

The tilt & turn friction stays are not supplied in the kits. See compatible friction stays on page 164.

■ **MANIOBRA LÓGICA + CREMONA CON LLAVE**  
TILT-BEFORE-TURN + CREMONE WITH KEY

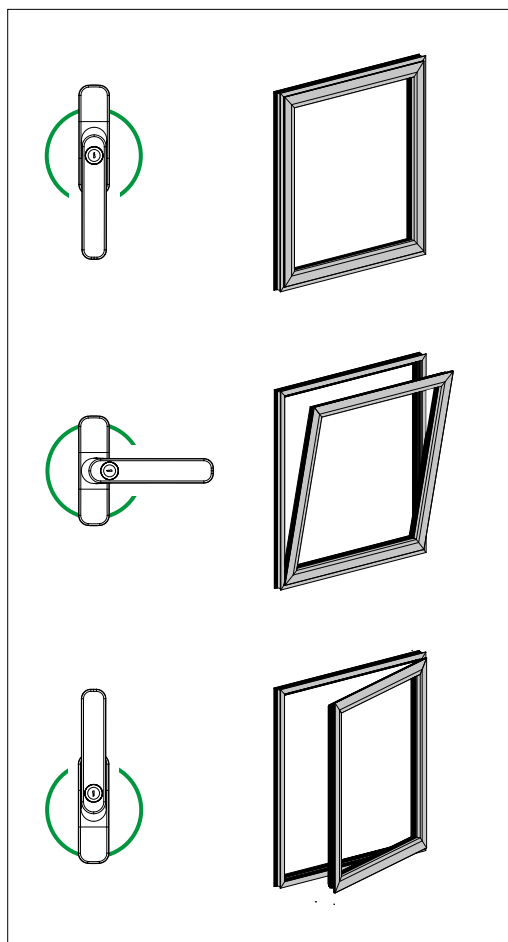

Cremonas compatibles Compatible cremones  
SIRIUS BLOCK / LYRA BLOCK

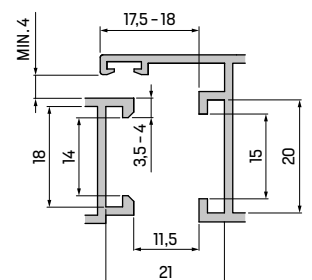

14, 18 CANAL EUROPEO » EJE 10  
EURO GROOVE » TO SHAFT



**CAMBIO DE APERTURA: DE MANO DERECHA A MANO IZQUIERDA**  
CHANGE OF OPENING: FROM RIGHT HAND TO LEFT HAND

**BISAGRA SUPERIOR** UPPER HINGE  
**PALA HOJA** SASH LEAF

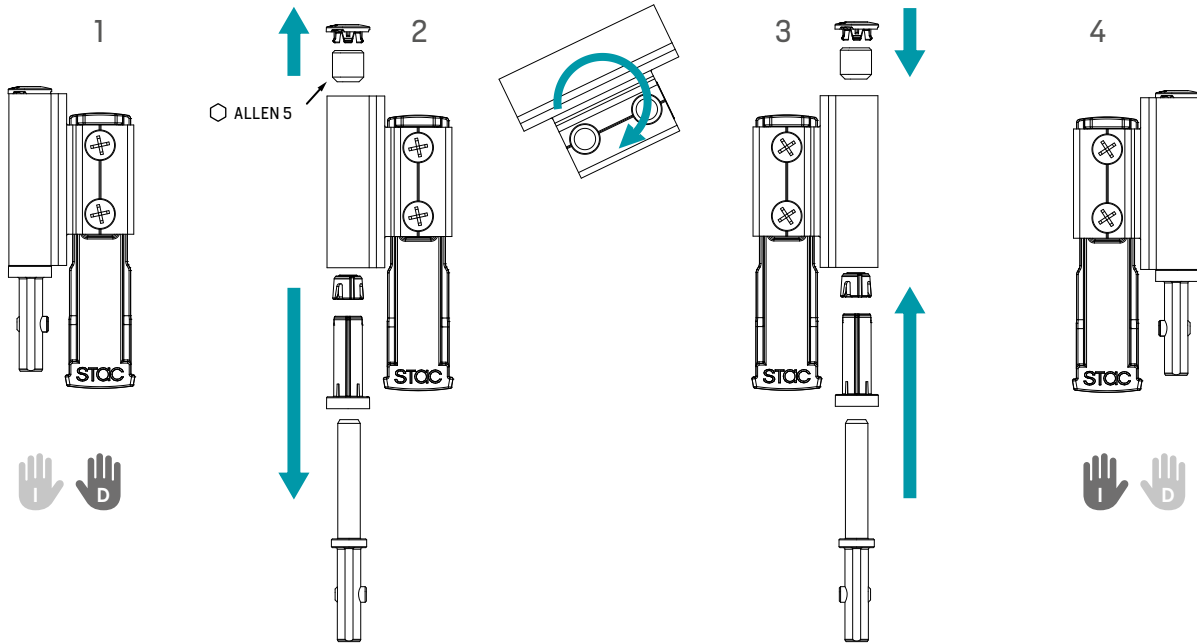

**BISAGRA INFERIOR** LOWER HINGE  
**PALA MARCO** FRAME LEAF

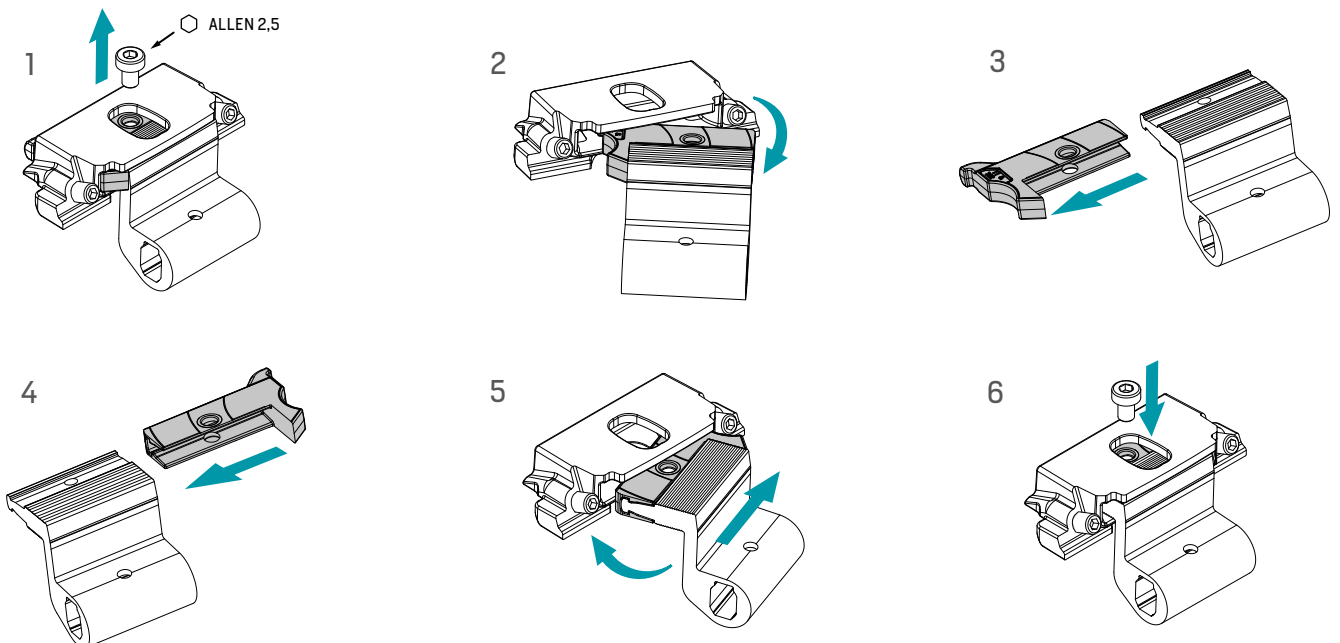

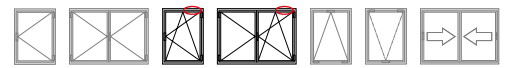

## COMPASES OSCILOBATIENTES

TILT & TURN FRICTION STAYS



### COMPASES DE MANIOBRA CLÁSICA

CLASSIC MANOEUVRE FRICTION STAYS

110309	MICRO	ZM INX
B110302	PEQUEÑO SMALL	CE
B110301	GRANDE LARGE	
T110301	CLX	





### COMPASES DE MANIOBRA LÓGICA

CLASSIC TILT-BEFORE-TURN FRICTION STAYS

A110305	PEQUEÑO SMALL	ZM INX
A110304	GRANDE LARGE	CE
T110304	CLX	





Los compases permiten realizar aperturas oscilobatientes en combinación con los diferentes herrajes.

- Los kits oscilobatientes se disponen de 2 tipos de compases: maniobra clásica y maniobra lógica.
- Los compases se suministran con excéntrica encasquada que permite regular la presión de cierre.
- Los elementos deslizantes incorporan un clip para eliminar holguras.
- Las piezas de zamak han sido tratadas para garantizar resistencia a la corrosión de 240 horas en cámara de niebla salina de acuerdo con lo establecido en la norma UNE-EN 1670 (Grado 4).

#### Maniobra clásica

- Disponibles cuatro tamaños de compases: micro, pequeño, grande y CLX.
- El compás micro permite añadir un ángulo de reenvío suplementario demandado por el mercado de la rehabilitación.

#### Maniobra lógica

- Disponibles tres tamaños de compases: pequeño, grande y CLX.

The friction stays allow tilt & turn openings to be made in combination with the various hardware.

- There are 2 types of frictions in the tilt & turn kits: classic manouevre and tilt-before-turn.
- The friction stays are supplied with an eccentric cam which allows the closing pressure to be regulated.
- Sliding elements are fitted with an anti-looseness clip.
- The zamak parts have been treated to guarantee 240 hours of corrosion resistance in a saline mist chamber in accordance with the UNE-EN 1670 standard (Grade 4).

#### Classic manouevre

- Four sizes of friction stays are available: micro, small, large and CLX.
- The micro friction stay allows you to add a supplementary corner drive required by the rehabilitation market.

#### Tilt-before-turn

- Three sizes of friction stays are available: small, large and CLX.

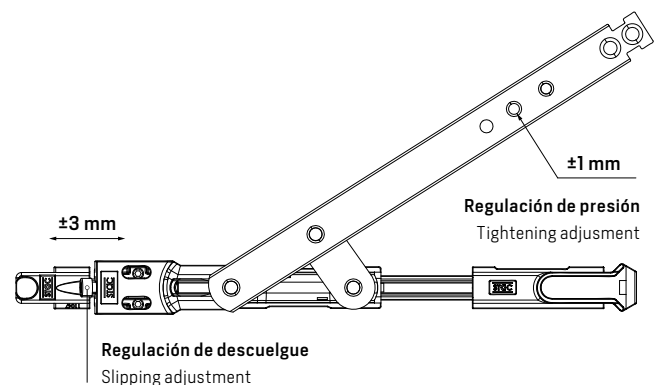

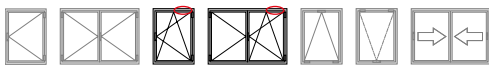

**REFERENCIAS**  
REFERENCES

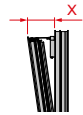
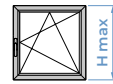
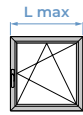
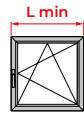
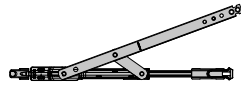

► **CLASSIC, SMART, CLX ANODIC**



110309	<b>MICRO</b>	345	700	450	2600	110	120 kg	L-309	-
B110302	<b>PEQUEÑO</b>	442	750	500	2600	138	120 kg	L-373	-
A110305	SMALL								
B110301	<b>GRANDE</b>	570	1200	700	2600	183	120 kg	L-495	-
A110304	LARGE								
B110301 + A130301	<b>GRANDE + SUPLEMENTARIO</b>	910	1500	700	2600	183	120 kg	L-595	-
A110304 + A130301	LARGE + SUPPLEMENTARY	1200						L-965	325

► **CLX**



T110301	<b>GRANDE CLX</b>	570	1200	500	2800	135	160 kg	L-495	-
T110304	LARGE CLX								
T110301 + A130301	<b>GRANDE CLX + SUPLEMENTARIO</b>	910	1500	500	2800	135	160 kg	L-595	-
T110304 + A130301	LARGE CLX + SUPPLEMENTARY	1200						L-965	325

► **CH180+**



H1213R3/L3	<b>CH180+ PEQUEÑO</b>	470	1000	550	2600	90	100 kg	L-432	-
H1213R4/L4	CH180+ SMALL								
H1213R1/L1	<b>CH180+ GRANDE</b>	590	1200	650	2600	130	100 kg	L-516	-
H1213R2/L2	CH180+ LARGE								
H1213R1/L1 + A130301	<b>CH180+ + SUPLEMENTARIO</b>	930	2500	650	2600	130	100 kg	L-616	-
H1213R2/L2 + A130301	CH180+ + SUPPLEMENTARY	1220						L-986	325

■ **MANIOBRA CLÁSICA**  
CLASSIC MANOEUVRE

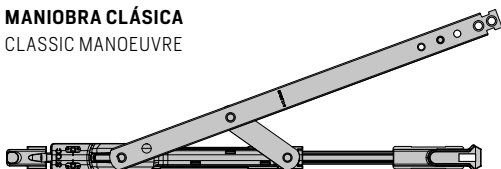

■ **MANIOBRA LÓGICA**  
TILT-BEFORE-TURN

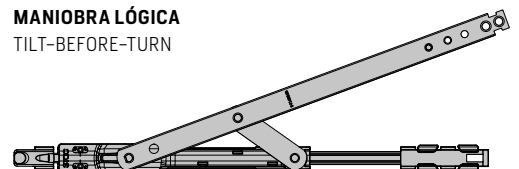

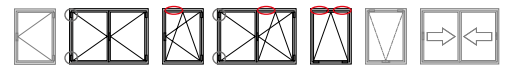

**COMPÁS SUPLEMENTARIO**  
SUPPLEMENTARY CORNER DRIVE

A130301

15



Los compases permiten realizar aperturas oscilobatientes en combinación con los diferentes herrajes.

The friction stays allow tilt & turn openings to be made in combination with the various hardware.

**Compás suplementario**

- Compás recomendado para ventanas de apertura oscilobatiente a partir de 1200 mm de largo de hoja.
- El compás actúa como refuerzo al compás principal reduciendo los esfuerzos y vibraciones en el mismo cuando la ventana se halla en posición de oscilo.
- El compás suplementario se suministra premontado, lo que permite una rápida instalación.
- El compás suplementario es válida para aperturas de ventana abatibles.

**Supplementary corner drive**

- Friction stay recommended for tilt & turn opening windows from 1200 mm sash length.
- The friction stay acts as a reinforcement to the main friction stay reducing the efforts and vibrations when the window is in the tilt position.
- The supplementary friction stay is supplied pre-assembled, allowing for rapid installation.
- The supplementary friction stay is suitable for bottom-hung openings.

**FALSO COMPÁS PARA HOJA PASIVA**  
TOP HINGE ADAPTER FOR PASSIVE SASH

T110100

100



**Falso compás**

- El falso compás es compatibles con las bisagras oscilobatientes CLX 160 kg, CLASSIC 120 kg y SMART 90 kg.
- Regulación horizontal:  $\pm 3$  mm.
- Regulación de presión:  $\pm 1,5$  mm.
- Se recomienda su instalación con bisagras oscilobatientes CLX por el amplio rango de regulación que ofrece respecto a la carga que soportan las bisagras.

**Top hinge adapter**

- The top hinge adapter is compatible with the CLX 160 kg, CLASSIC 120 kg and SMART 90 kg tilt & turn hinges.
- Horizontal adjustment:  $\pm 3$  mm.
- Tightening adjustment:  $\pm 1.5$  mm.
- Installation with CLX tilt & turn hinges is recommended because of the wide adjustment range it offers in relation to the load supported by the hinges.

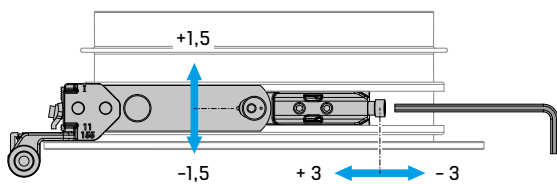

**■ INSTALACIÓN ASSEMBLY T110100**

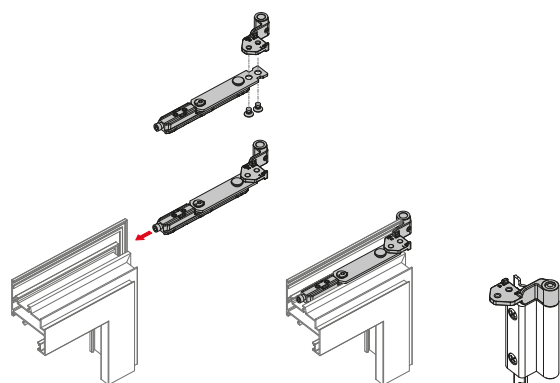

**■ MANIOBRA TRADICIONAL TRADITIONAL OPERATION**

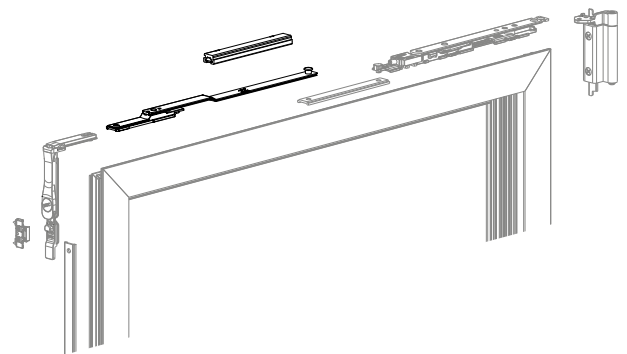

**■ MANIOBRA LÓGICA TILT-BEFORE-TURN**

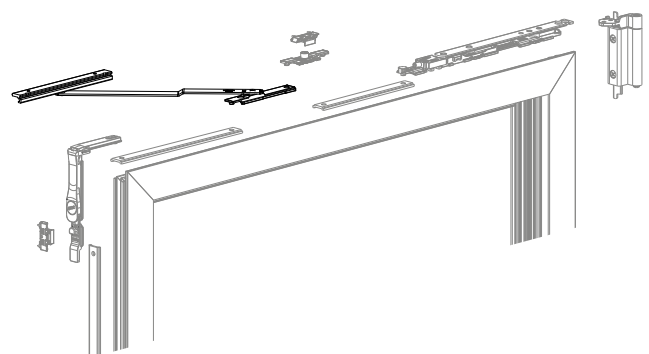

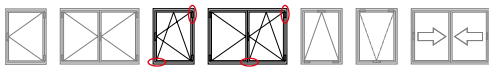

Supplementary corner drives for tilt & turn opening windows.

- The supplementary corner drives provide additional locking points by coupling them to the terminal of the active sash or to the tail of the tilt & turn friction stay.
- The zamak parts have been treated to guarantee 240 hours of corrosion resistance in a saline mist chamber in accordance with the UNE-EN 1670 standard (Grade 4).

**A112100**

- It is recommended that it be installed at sash heights of over 1200 mm vertically and 1200 mm horizontally.

**B112100**

- It is recommended that it be installed at sash heights of over 1200 mm.
- Simple installation as the coupling with the friction stay is done without having to dismantle the hardware.
- Compact support casing with the aim of reducing contact with the upper hinges.

**H122100**

- It is recommended that it be installed at sash heights of over 1200 mm.
- Supplementary corner drive specifically designed for use with the CH180+ concealed hinges.

Ángulos de reenvío suplementarios para ventanas de apertura oscilobatiente.

- Los ángulos de reenvío suplementarios permiten disponer de puntos de cierre adicionales acoplándolos con el terminal de la hoja activa o en la cola del compás oscilobatiente.
- Las piezas de zamak han sido tratadas para garantizar resistencia a la corrosión de 240 horas en cámara de niebla salina de acuerdo con lo establecido en la norma UNE-EN 1670 (Grado 4).

**A112100**

- Se recomienda su instalación en alturas de hoja superiores a 1200 mm en vertical y 1200 mm en horizontal.

**B112100**

- Se recomienda su instalación en alturas de hoja superiores a 1200 mm.
- Instalación simple ya que el acoplamiento con el compás se realiza sin necesidad de desmontar el herraje.
- Carcasa de soporte compacta con el objetivo de reducir el contacto con las bisagras superiores.

**H122100**

- Se recomienda su instalación en alturas de hoja superiores a 1200 mm.
- Ángulo de reenvío suplementario específicamente diseñado para su uso con las bisagras ocultas CH180+.

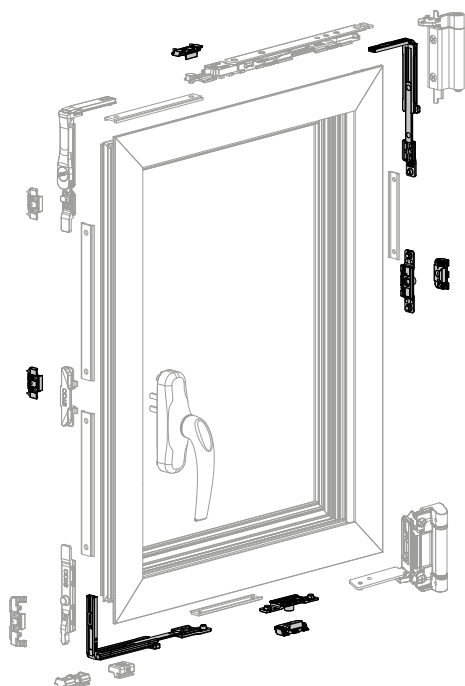

**ÁNGULO DE REENVÍO SUPLEMENTARIO**  
SUPPLEMENTARY CORNER DRIVE

ZM INX



A112100



**ÁNGULO DE REENVÍO SUPLEMENTARIO**  
SUPPLEMENTARY CORNER DRIVE

ZM INX



B112100



**ÁNGULO DE REENVÍO SUPLEMENTARIO CH180+**  
CH180+ SUPPLEMENTARY CORNER DRIVE

ZM INX



H122100



**KIT DE BISAGRAS CLASSIC PARA HOJA ACTIVA**

CLASSIC HINGE KIT FOR ACTIVE SASH

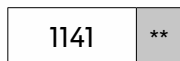

**KIT DE BISAGRAS CLASSIC PARA HOJA PASIVA**

CLASSIC HINGE KIT FOR PASSIVE SASH

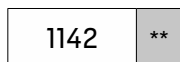

**EMBALAJE INDUSTRIAL**

Tipo de embalaje destinado a facilitar el montaje de grandes producciones de kits oscilobatientes industriales. El kit base se compone de las siguientes referencias:

- Kit de bisagras oscilobatientes CLASSIC válidas para hoja activa y hoja pasiva.
- Kits base oscilobatientes (cierre al inversor, cierre al marco y maniobra lógica).
- Cremonas SIRIUS y LYRA (sin fundas de transmisión).

**KIT DE BISAGRAS**

Se suministran en una caja con 20 juegos de bisagras. La ventaja respecto al kit base es que se elimina las bolsas donde van habitualmente las bisagras consiguiendo con esto reducir los tiempos de montaje ya que trabajador no tiene que abrir las bolsas.

Además las bisagras de hoja tienen el eje de la bisagra inferior insertado ya de fábrica en la pala de hoja. Por defecto, y en stock las bisagras están premontadas a derechas.

Las piezas van sobre blísters de plástico y la distribución de las piezas ha sido pensada para ahorrar tiempo en aquellas carpinterías donde existen dos líneas de montaje, una para los marcos y otra para las hojas.

Cada caja tiene 3 bandejas:

**BULK PACKAGING**

Type of packaging designed to facilitate the assembly of large productions of industrial tilt & turn kits. The base kit consists of the following references:

- CLASSIC tilt & turn hinge kit valid for active and passive sash.
- Tilt & turn base kits (locking to inverter, locking to frame and tilt-before-turn).
- SIRIUS and LYRA cremones (without transmission covers).

**HINGE KIT**

They are supplied in boxes containing 20 hinge sets. The advantage of this with respect to the base kit is that it eliminates the bags that the hinges are habitually packed in and in this way it reduces the assembly times and the operator does not have to open bags.

Furthermore, the sash hinges have the lower hinge shaft already fitted at the factory in the sash blade. By default, and in stock, the hinges are pre-assembled for the right hand side.

The parts are placed in plastic blister packs and the distribution of the parts has been thought out in order to save time in workshops where there are two assembly lines, one for frames and the other for sashes.

Each box has three trays placed:

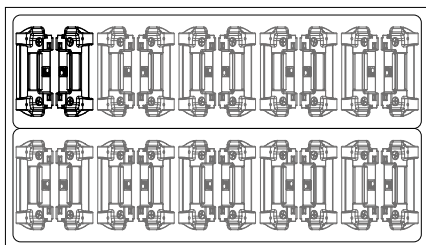

**BLISTER 1**

Contiene todas las palas de marco con las pletinas de INOX y los tornillos premontados.

It contains all the frame leaves with the stainless steel plates and screws are pre-assembled.

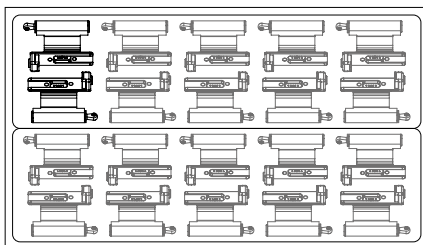

**BLISTER 2**

Contiene todas las palas de hoja con el eje ya montado de fábrica.

It contains all the sash leaves with the shaft already assembled from the factory.

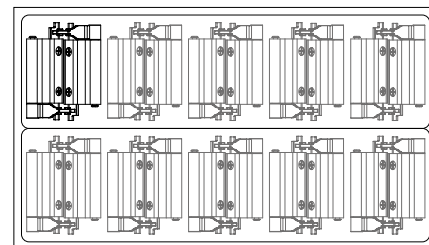

**BLISTER 3**

Contiene las bisagras superiores completamente premontadas a derechas.

It contains the upper hinges completely pre-assembled to the right hand side.

**NOTA** Recordamos que las bisagras van premontadas a derechas. Para colores y acabados especiales póngase en contacto con nuestro departamento comercial.

Please be aware that the hinges are pre-assembled to the right hand side. For special colours and finishes, please contact our Sales Department.

This code includes all the sash and frame parts that are not overridden by the hardware colour.

Just as the previously mentioned hinge kit where the traditional packaging has been eliminated and the parts are supplied in bulk and totally pre-assembled and separated in two groups, one being the parts to be assembled in the sash: corner drive, positioning latch and sash anti-lever,... and the other being the parts that are for the frame such as the keepers, frame strike plates, etc.

In the industrial tilt & turn kit, the cremone transmission cover and the active sash terminal are not included because the client can use one unique transmission rod that is fabricated in our die-cutting machines TFS-04, TFS-05 and TFS-06.

Bajo este código se incluyen todas las piezas de hoja y marco que no están supeditadas al color del herraje.

Al igual que el kit de bisagras comentado anteriormente, se han eliminado del embalaje tradicional todas las bolsas y las piezas se suministran a granel totalmente premontadas y separadas en dos grupos: por un lado las piezas que van montadas en la hoja: ángulo de reenvío, resbalón de posicionamiento y antipalanca de hoja, etc. y por otro lado las piezas que van en el marco, como son los cerraderos, resbalones de marco, etc.

En el kit oscilo industrial no se incluyen la funda de transmisión de cremona ni el terminal hoja activa ya que el cliente puede utilizar una única falleba troquelada en nuestras máquinas troqueladoras TFS-04, TFS-05 y TFS-06.

■ **PUNTERO DE HOJA ACTIVA**  
ACTIVE SASH POINTER

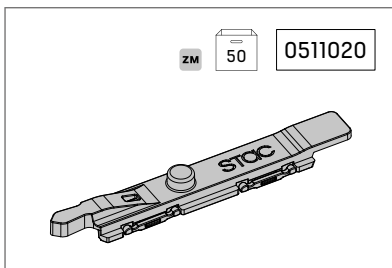

NO SE INCLUYEN EN EL EMBALAJE INDUSTRIAL

■ **FUNDA DE TRANSMISIÓN**  
TRANSMISSION COVER

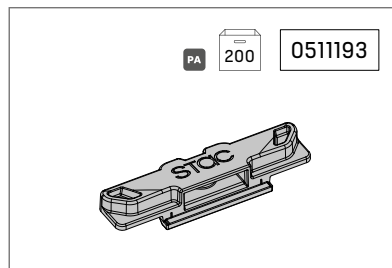

NOT INCLUDED IN BULK PACKAGING

**COMPONENTES DE LOS KITS BASE OSCIOBATIENTES**  
COMPONENTS OF THE TILT & TURN BASE KITS



114000	<b>KIT CIERRE AL INVERSOR CON CERRADERO DE PLÁSTICO</b> LOCKING TO INVERTER KIT WITH PLASTIC KEEPER	20
114000Z	<b>KIT CIERRE AL INVERSOR CON CERRADERO DE ZAMAK</b> LOCKING TO INVERTER KIT WITH ZAMAK KEEPER	20
A114010	<b>KIT CIERRE AL MARCO</b> LOCKING TO FRAME KIT	20
A114020	<b>KIT MANIOBRA LÓGICA</b> TILT-BEFORE-TURN KIT	20

**ELEMENTOS DE HOJA** SASH PARTS ■  
**ELEMENTOS DE MARCO** FRAME PARTS ■

**KITS OSCIOBATIENTES**  
TILT & TURN KITS

**114000**

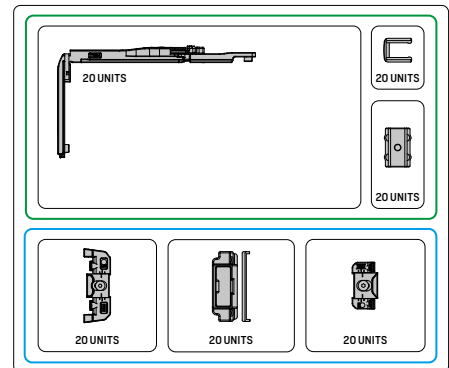

**114000Z**

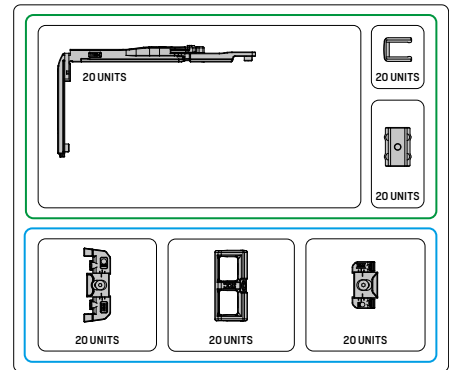

**A114010**

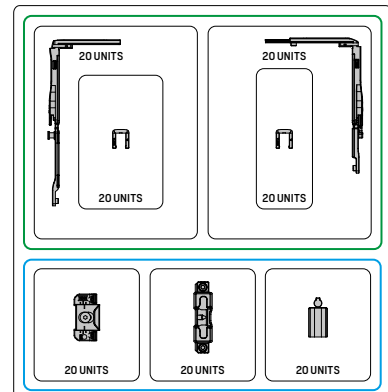

**A114020**

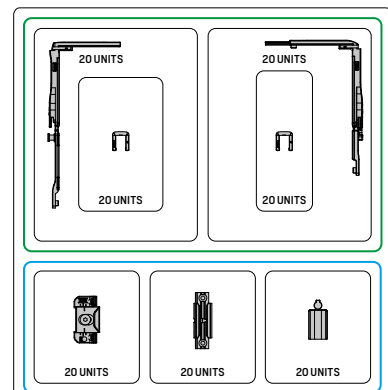



**CREMONA SIRIUS SIN FUNDA**

SIRIUS CREMONE WITHOUT COVER

A1157 \*\*

20



\*\*

RAL

AL ZM

INX AC

PA

A continuación aparecen las referencias básicas de las cremonas oscilobatientes SIRIUS y LYRA con escudo redondo y cuadrado. Estas referencias no incluyen la funda de transmisión (ref. 0511193).

Todas las cremonas por defecto están pre-montadas a derechas para aperturas oscilobatientes. Para pedidos superiores a 500 cremonas y con plazo de entrega de 3 semanas se puede escoger el accionamiento por defecto (oscilo o practicable), así como mano de montaje [a derecha o a izquierdas].

In continuation the basic references can be seen for the SIRIUS and LYRA tilt & turn cremones and the variants of rounded or squared escutcheons. These references do not include the transmission cover (ref. 0511193).

All the cremones are by default pre-assembled on the right for tilt & turn openings. For orders above 500 cremones and with a lead time of 3 weeks, you can select the default action [tilt & turn or side-hung] as well as the assembled turn position [right-hand or left-hand].

**CREMONA LYRA SIN FUNDA**

LYRA CREMONE WITHOUT COVER

1135 \*\*

25



\*\*

RAL

AL ZM

INX PA

■ APERTURA PRACTICABLE  
SIDE-HUNG OPENING

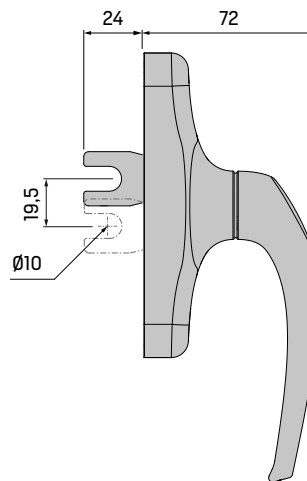

■ APERTURA OSCIOBATIENTE  
TILT & TURN OPENING

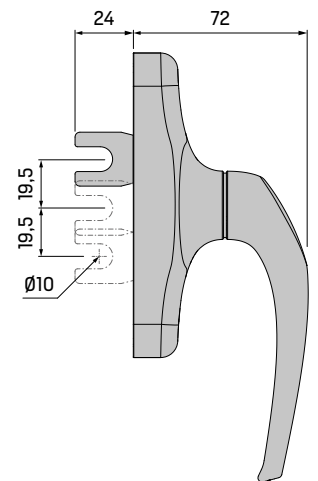

**CREMONA CUADRADA LYRA SIN FUNDA**

LYRA SQUARE CREMONE WITHOUT COVER

1135 \*\* C

25



\*\*

RAL

AL ZM

INX PA



REMACHE Ø6  
Ø6 RIVET

0517002

50



REMACHE Ø8  
Ø8 RIVET

0511088

50



PUNTO DE CIERRE REGULABLE  
ADJUSTABLE LOCKING POINT

110200

500



FALLEBA DE TRANSMISIÓN DE POLIAMIDA  
POLYAMIDE TRANSMISSION ROD

059233

250 m



PLANTILLA PARA MONTAJE DE HERRAJE OSCIOBATIENTE  
TEMPLATE FOR TILT & TURN HARDWARE INSTALLATION

STC-P-01

PP

50

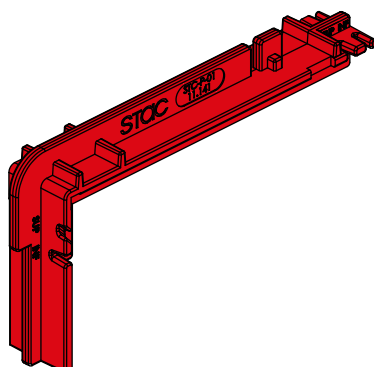

- Permite realizar el corte de las gomas y posicionar el herraje para su instalación  
Allows the cutting of the rubbers and the positioning of the hardware for installation

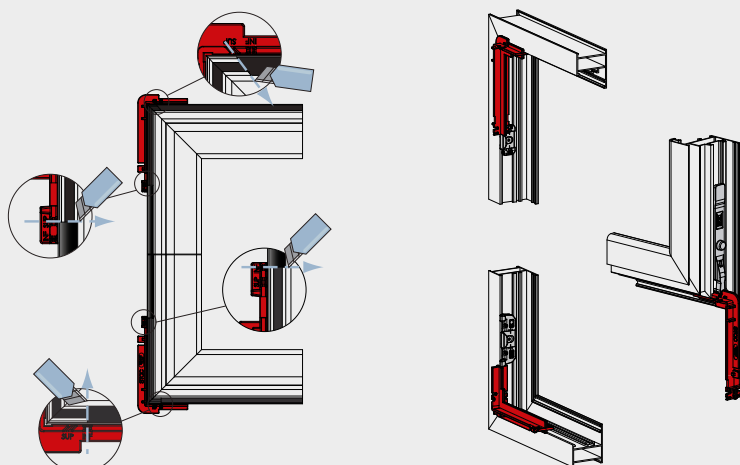



**POSICIONES DE APERTURA DE LAS VENTANAS**  
WINDOW OPENING POSITIONS

■ **CERRADO**  
CLOSED

 **FUERZA MÁXIMA 10 kg**  
MAXIMUM FORCE 10 kg

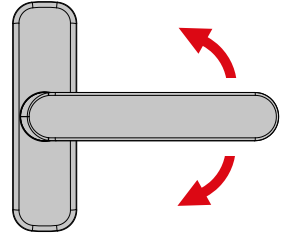
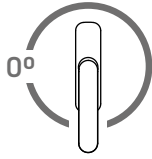
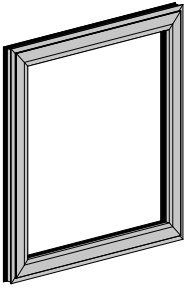

■ **CIERRE AL INVERSOR Y CIERRE AL MARCO**  
LOCKING TO INVERTER AND LOCKING TO FRAME

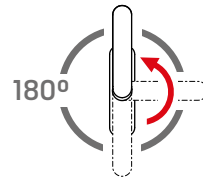
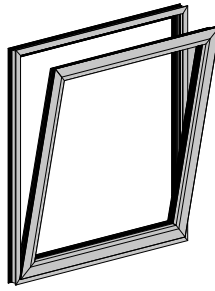
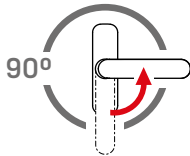
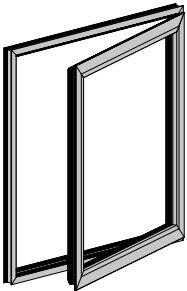

■ **MANIOBRA LÓGICA**  
TILT-BEFORE-TURN

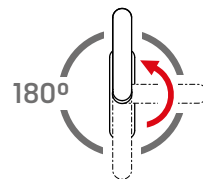
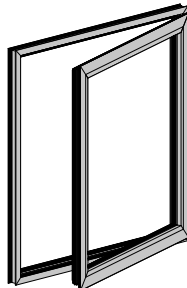
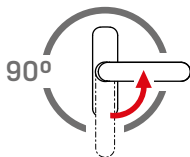
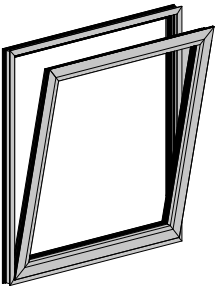

**BLOQUEO DE LAS POSICIONES EN MANIOBRA LÓGICA CON LA CREMONA CON LLAVE LYRA BLOCK**  
LOCKING OF THE POSITIONS IN TILT-BEFORE-TURN WITH THE LYRA BLOCK CREMONE

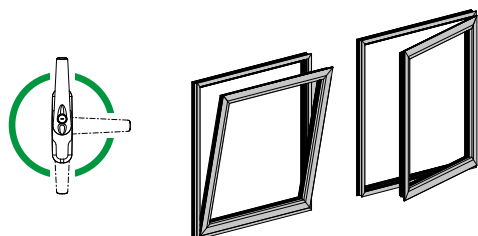

■ LLAVE KEY 0°

La ventana permite oscilar y abrir  
The window allows to tilt and open

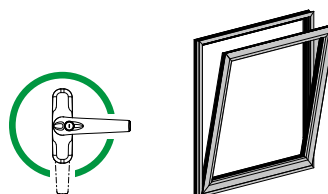

■ LLAVE KEY 90°

La ventana solo permite oscilar  
The window only allows to tilt

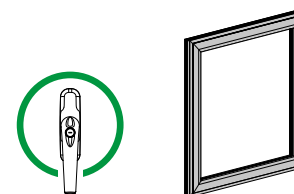

■ LLAVE KEY 180°

La ventana ni permite oscilar ni abrir  
The window does not allow tilt or opening



**POSICIONES DE MICROVENTILACIÓN DE LAS CREMONAS**  
MICRO-VENTILATION POSITIONS OF THE CREMONES



■ APERTURA OSCIOBATIENTE  
TILT & TURN OPENING

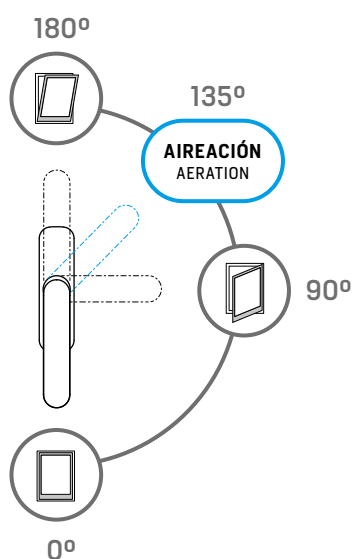

■ APERTURA PRACTICABLE  
SIDE-HUNG OPENING

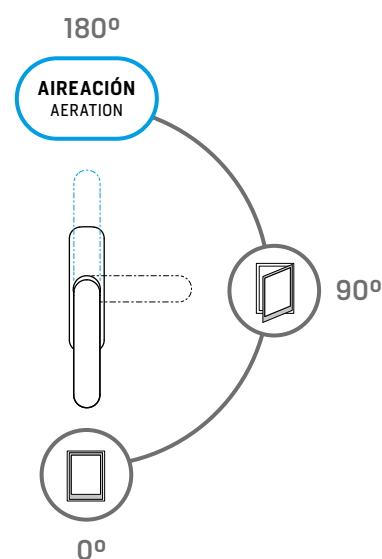



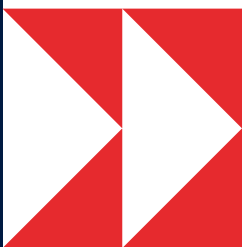

# 06

## HERRAJE EVO-SOFT EVO-SOFT HARDWARE



- 176 **Herraje encasquillado EVO-SOFT**  
EVO-SOFT encased hardware
- 177 **Kits oscilobatientes con cierre al inversor**  
Tilt & turn kits with locking to inverter
- 178 **Kits oscilobatientes con cierre al marco**  
Tilt & turn kits with locking to frame
- 179 **Kit oscilobatientes con maniobra lógica**  
Tilt-before-turn kit
- 180 **Configuraciones de apertura practicable**  
Side-hung opening configurations
- 181 **Configuraciones de apertura oscilobatientes**  
Tilt & turn opening configurations
- 182 **Accesorios EVO-SOFT**  
EVO-SOFT accessories





Herraje mejorado con casquillos en los puntos de cierre para prolongar la durabilidad de los cerraderos y reducir el desgaste por rozamiento, a la vez que se facilita una mayor suavidad de cierre.

Improved hardware with bushings at the locking points to prolong the durability of the keepers and reduce friction wear, while facilitating a smoother closing.

» **PUNTO DE CIERRE TERMINAL**

Elemento de acero estampado que incorpora un punto de cierre EVO-SOFT. El punto de cierre terminal está diseñado para ser instalado a continuación de cualquier pieza del herraje de hoja: compás, ángulo de reenvío o funda de transmisión,...

**TERMINAL LOCKING POINT**

Stamped steel element that incorporates a SOFT locking point. It is designed to be installed next to any part of the sash hardware: friction stay, corner drive or cremone transmission cover.



» **PUNTO DE CIERRE INTERMEDIO**

El punto de cierre intermedio permite intercalar todos los puntos de cierre que se necesitan en configuraciones de ventana de grandes dimensiones. Incorpora un punto de cierre EVO-SOFT y un clip anti-holguras.

**INTERMEDIATE LOCKING POINT**

The intermediate locking point allows you to insert as many locking points as you need in large window configurations. It incorporates an EVO-SOFT locking point and an anti-looseness clip.



» **COMPÁS**

Los compases oscilobatientes están provistos de excéntrica encasquillada que permite regulación de apriete de  $\pm 1$  mm. Esta mejora se aplica a todos los compases existentes manteniendo las mismas referencias.

**FRICTION STAY**

The tilt & turn friction stays are equipped with an eccentric cam that allows for a tightening adjustment of  $\pm 1$  mm. This improvement is applied to all existing compasses maintaining the same references.



» **PUNTO DE CIERRE FALLEBA**

Disponibles remaches EVO-SOFT encasquillados para puntos de cierre en cánulas para su uso en máquinas troqueladoras de fallebas STAC: TFS04, TFS05 y TFS06.

**TRANSMISSION ROD LOCKING POINT**

EVO-SOFT encased rivets are available for STAC TFS die-cutting machines: TFS04, TFS05 and TFS06.

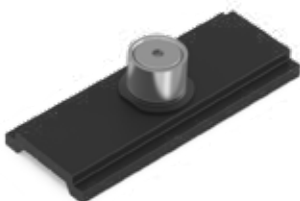

» **PUNTERO**

Elemento de posicionamiento para realizar el basculamiento de la ventana. Incorpora un punto de cierre EVO-SOFT y un clip antiholguras.

**POINTER**

Positioning element to make the window tilt. It incorporates an EVO-SOFT locking point and a anti-looseness clip.



» **ÁNGULO DE REENVÍO**

El ángulo de reenvío para aperturas oscilobatientes dispone de un punto de cierre encasquillado EVO-SOFT y un clip antiholguras.

**CORNER DRIVE**

The corner drive for tilt & turn openings has an EVO-SOFT locking point and a anti-looseness clip.



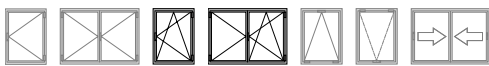

Specially designed kits for tilt & turn openings with locking to the frame with encased locking points.

- The EVO-SOFT kits are supplied with adjustable hinges.
- EVO-SOFT locking points are encased and adjustable.
- The closing effort is up to 50% less compared to the use of traditional hardware.
- Possibility of adding multiple locking points.
- All sliding elements are fitted with an anti-looseness clip.
- The screws and metal parts are made of stainless steel.
- The zamak parts have been treated to guarantee 240 hours of corrosion resistance in a saline mist chamber in accordance with the UNE-EN 1670 standard (Grade 4).

The tilt & turn friction stays are not supplied in the kits. See compatible friction stays on page 164.

Kits diseñados para aperturas oscilobatientes de cierre al inversor con puntos de cierre encasquillados.

- Los kits EVO-SOFT vienen provistos de bisagras con regulación.
- Puntos de cierre encasquillados EVO-SOFT y con regulación.
- El esfuerzo de cierre es hasta un 50% menor en comparación con el uso de herraje tradicional.
- Posibilidad de añadir múltiples puntos de cierre.
- Todos los elementos deslizantes incorporan un clip antiholguras.
- La tornillería y las piezas metálicas están fabricadas en acero inoxidable.
- Las piezas de zamak han sido tratadas para garantizar resistencia a la corrosión de 240 horas en cámara de niebla salina de acuerdo con lo establecido en la norma UNE-EN 1670 (Grado 4).

Los compases oscilobatientes no se incluyen en los kits. Consulte los compases compatibles en la página 164.

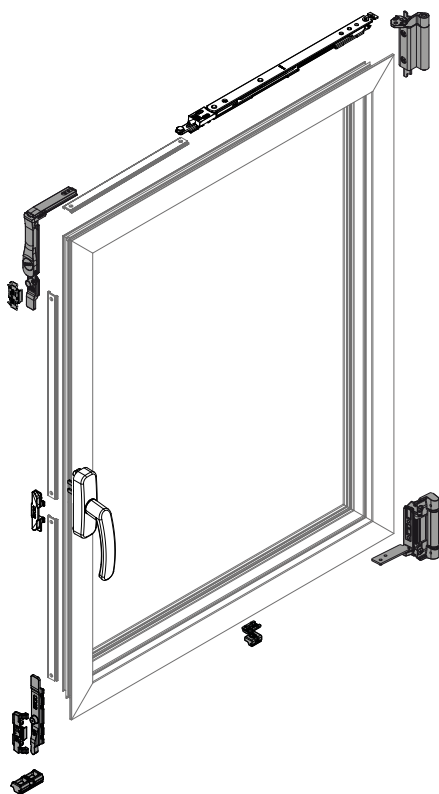

**CIERRE AL INVERSOR SIN CREMONA**  
LOCKING TO INVERTER WITHOUT CREMONE

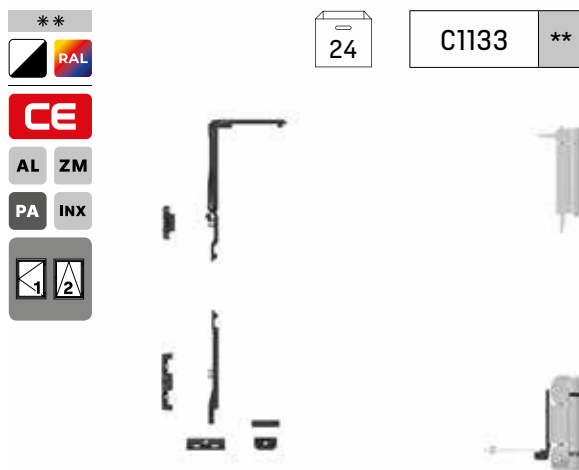

**CIERRE AL MARCO CON CREMONA LYRA**  
LOCKING TO INVERTER WITH LYRA CREMONE



**CIERRE AL INVERSOR CON CREMONA SIRIUS**  
LOCKING TO INVERTER WITH SIRIUS CREMONE



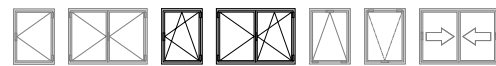

**CIERRE AL MARCO SIN CREMONA**

LOCKING TO THE FRAME WITHOUT CREMONE

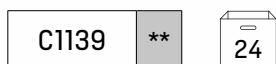

Kits diseñados para aperturas oscilobatientes de cierre al marco con puntos de cierre encasquillados.

- Los kits EVO-SOFT vienen provistos de bisagras con regulación.
- Puntos de cierre encasquillados EVO-SOFT y con regulación, excepto el ángulo de reenvío inferior que incluye un punto de cierre de seguridad.
- El cerradero de basculamiento se suministra con el resbalón de hoja integrado.
- Posibilidad de añadir múltiples puntos de cierre.
- Todos los elementos deslizantes incorporan un clip antiholguras.
- La tornillería y las piezas metálicas están fabricadas en acero inoxidable.
- Las piezas de zamak han sido tratadas para garantizar resistencia a la corrosión de 240 horas en cámara de niebla salina de acuerdo con lo establecido en la norma UNE-EN 1670 (Grado 4).

Specially designed kits for tilt & turn openings with locking to the frame with encased locking points.

- The EVO-SOFT kits are supplied with adjustable hinges.
- EVO-SOFT locking points are encased and adjustable, except for the lower corner drive which includes a security locking point.
- The tilting keeper is supplied with the integrated sash positioning latch.
- Possibility of adding multiple locking points.
- All sliding elements are fitted with an anti-looseness clip.
- The screws and metal parts are made of stainless steel.
- The zamak parts have been treated to guarantee 240 hours of corrosion resistance in a saline mist chamber in accordance with the UNE-EN 1670 standard (Grade 4).

**CIERRE AL MARCO CON CREMONA LYRA**

LOCKING TO THE FRAME WITH LYRA CREMONE

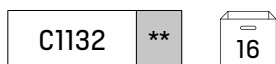

Los compases oscilobatientes no se incluyen en los kits. Consulte los compases compatibles en la página 164.

The tilt & turn friction stays are not supplied in the kits. See compatible friction stays on page 164.

**CIERRE AL MARCO CON CREMONA SIRIUS**

LOCKING TO THE FRAME WITH SIRIUS CREMONE

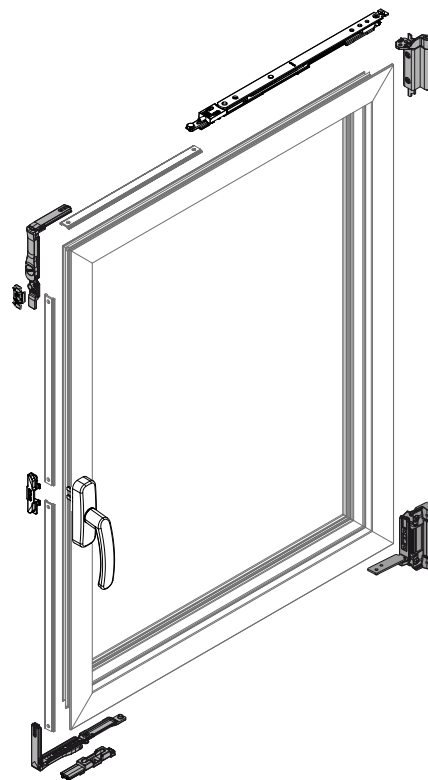
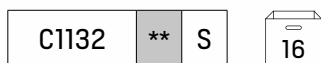



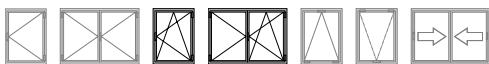

Specially designed kits for tilt & turn openings with locking to the frame with encased locking points.

- The EVO-SOFT kits are supplied with adjustable hinges.
- EVO-SOFT locking points are encased and adjustable, except for the lower corner drive which includes a security locking point.
- The tilting keeper is supplied with the integrated sash positioning latch.
- Possibility of adding multiple locking points.
- All sliding elements are fitted with an anti-looseness clip.
- The screws and metal parts are made of stainless steel.
- The zamak parts have been treated to guarantee 240 hours of corrosion resistance in a saline mist chamber in accordance with the UNE-EN 1670 standard (Grade 4).

Kits diseñados para aperturas oscilobatientes de cierre al marco con puntos de cierre encasquillados.

- Los kits EVO-SOFT vienen provistos de bisagras con regulación.
- Puntos de cierre encasquillados EVO-SOFT y con regulación, excepto el ángulo de reenvío inferior que incluye un punto de cierre de seguridad.
- El cerradero de basculamiento se suministra con el resbalón de hoja integrado.
- Posibilidad de añadir múltiples puntos de cierre.
- Todos los elementos deslizantes incorporan un clip antiholguras.
- La tornillería y las piezas metálicas están fabricadas en acero inoxidable.
- Las piezas de zamak han sido tratadas para garantizar resistencia a la corrosión de 240 horas en cámara de niebla salina de acuerdo con lo establecido en la norma UNE-EN 1670 (Grado 4).

The tilt & turn friction stays are not supplied in the kits. See compatible friction stays on page 164.

Los compases oscilobatientes no se incluyen en los kits. Consulte los compases compatibles en la página 164.

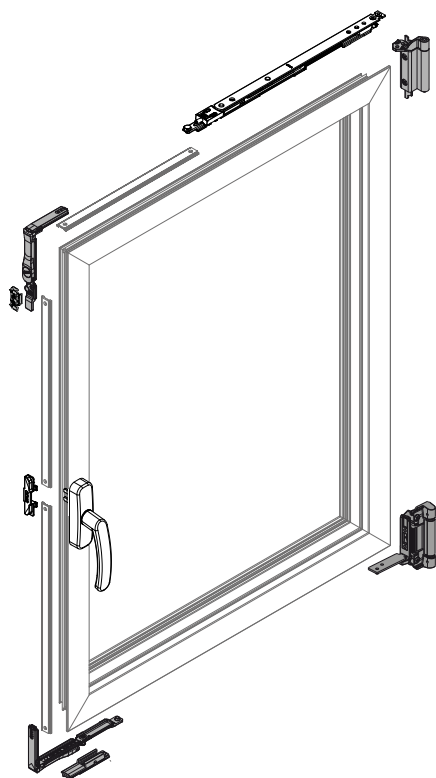

**MANIOBRA LÓGICA SIN CREMONA**  
TILT-BEFORE-TURN WITHOUT CREMONE

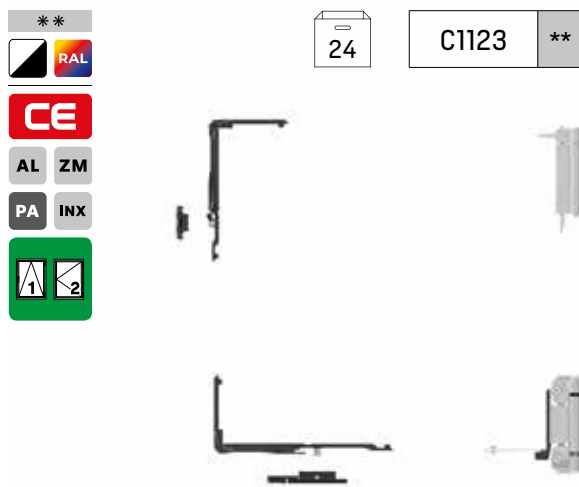

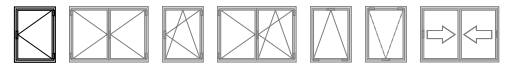

**CIERRE AL INVERSOR CON HERRAJE EVO-SOFT**  
LOCKING TO INVERTER WITH EVO-SOFT HARDWARE



1	<b>113003C</b>	<b>KIT PUNTO DE CIERRE INTERMEDIO EVO-SOFT</b> EVO-SOFT INTERMEDIATE LOCKING POINT KIT	50
2	<b>113004C</b>	<b>KIT PUNTO DE CIERRE TERMINAL EVO-SOFT</b> EVO-SOFT TERMINAL LOCKING POINT KIT	50
3	<b>0511149</b>	<b>PUNTO DE CIERRE: REMACHE EVO-SOFT</b> EVO-SOFT RIVET LOCKING POINT	50
4	<b>112500</b>	<b>PUNTO DE CIERRE OCULTO</b> CONCEALED LOCKING POINT	50
5	<b>0710621</b>	<b>KIT RESBALÓN DE POSICIONAMIENTO</b> POSITIONING LATCH KIT	100

■ **KIT BASE con puntos de cierre intermedios o remaches EVO-SOFT**  
BASE KIT with EVO-SOFT intermediate locking points or rivets

■ **H > 1200 mm**

■ **CREMONA Y BISAGRAS** CREMONE AND HINGES

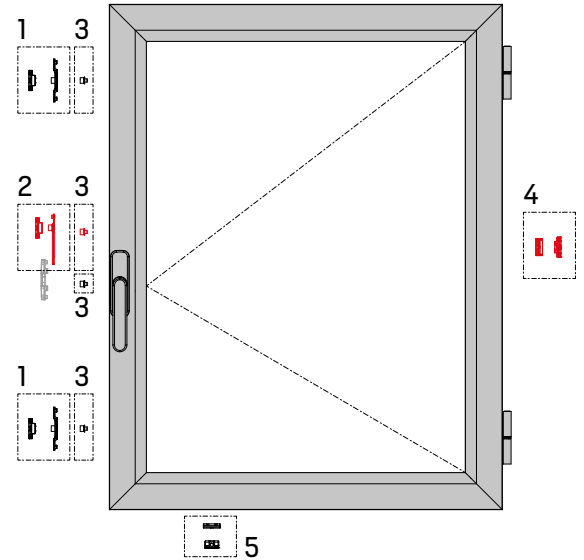

**CIERRE AL MARCO CON HERRAJE EVO-SOFT**  
LOCKING TO FRAME WITH EVO-SOFT HARDWARE



1	<b>113420C</b>	<b>KIT ÁNGULO DE REENVÍO HORIZONTAL EVO-SOFT</b> EVO-SOFT HORIZONTAL CORNER DRIVE KIT	20
2	<b>113003C</b>	<b>KIT PUNTO DE CIERRE INTERMEDIO EVO-SOFT</b> EVO-SOFT INTERMEDIATE LOCKING POINT KIT	50
3	<b>113004C</b>	<b>KIT PUNTO DE CIERRE TERMINAL EVO-SOFT</b> EVO-SOFT TERMINAL LOCKING POINT KIT	50
4	<b>112500</b>	<b>PUNTO DE CIERRE OCULTO</b> CONCEALED LOCKING POINT	50
5	<b>0517193</b>	<b>RESBALÓN DE POSICIONAMIENTO</b> POSITIONING LATCH	100

■ **CONFIGURACIÓN RECOMENDADA 113420C (2 unidades)**  
RECOMMENDED CONFIGURATION 113420C (2 units)

■ **H > 1200 mm**

■ **L > 1200 mm**

■ **CREMONA Y BISAGRAS** CREMONE AND HINGES

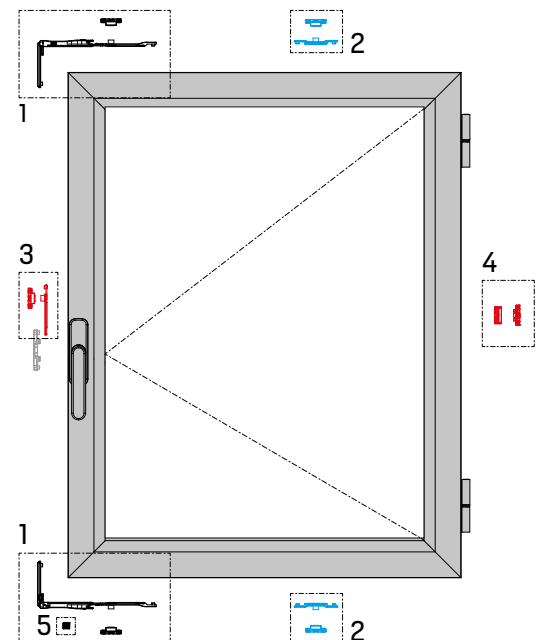

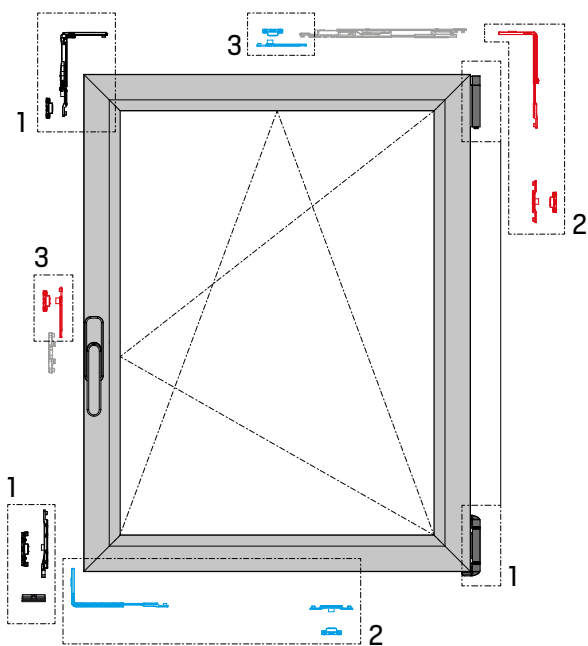

**CIERRE AL INVERSOR CON HERRAJE EVO-SOFT**  
LOCKING TO INVERTER WITH EVO-SOFT HARDWARE



1	<b>C1133</b>	**	<b>KIT CIERRE AL INVERSOR SIN CREMONA</b> LOCKING TO INVERTER KIT WITHOUT CREMONE	24
2	<b>A112103C</b>		<b>KIT ÁNGULO DE REENVÍO SUPLEMENTARIO EVO-SOFT</b> EVO-SOFT SUPPLEMENTARY CORNER DRIVE KIT	20
3	<b>113004C</b>		<b>KIT PUNTO DE CIERRE TERMINAL EVO-SOFT</b> EVO-SOFT TERMINAL LOCKING POINT KIT	50

■ **KIT BASE OSCILOBATIENTE C1133**  
C1133 TILT & TURN BASE KIT

■ **H > 1200 mm**

■ **L > 1200 mm**

■ **CREMONA Y COMPÁS** CREMONE AND FRICTION STAY

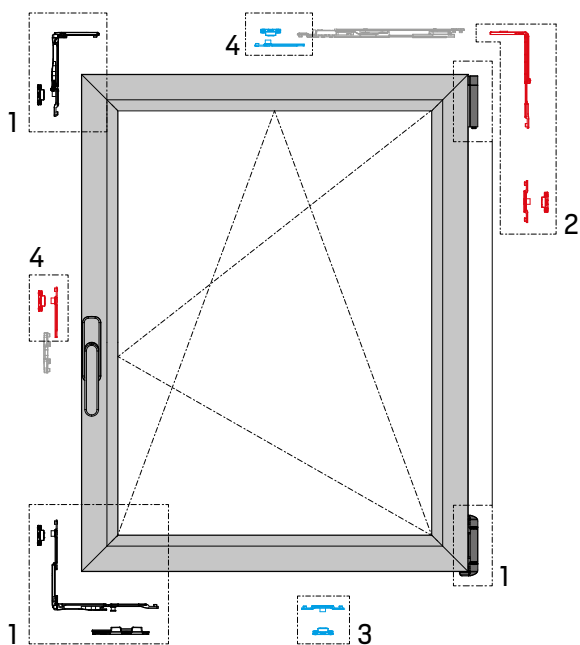

**CIERRE AL MARCO CON HERRAJE EVO-SOFT**  
LOCKING TO FRAME WITH EVO-SOFT HARDWARE



	<b>C1139</b>	**	<b>KIT CIERRE AL MARCO SIN CREMONA</b> LOCKING TO FRAME KIT WITHOUT CREMONE	
1				24
	<b>C1123</b>	**	<b>KIT MANIOBRA LÓGICA SIN CREMONA</b> TILT-BEFORE-TURN KIT WITHOUT CREMONE	
2	<b>A112103C</b>		<b>KIT ÁNGULO DE REENVÍO SUPLEMENTARIO EVO-SOFT</b> EVO-SOFT SUPPLEMENTARY CORNER DRIVE KIT	20
3	<b>113003C</b>		<b>KIT PUNTO DE CIERRE INTERMEDIO EVO-SOFT</b> EVO-SOFT INTERMEDIATE LOCKING POINT KIT	50
4	<b>113004C</b>		<b>KIT PUNTO DE CIERRE TERMINAL EVO-SOFT</b> EVO-SOFT TERMINAL LOCKING POINT KIT	50

■ **KIT BASE OSCILOBATIENTE C1139 / C1123**  
C1139 / C1123 TILT & TURN BASE KIT

■ **H > 1200 mm**

■ **L > 1200 mm**

■ **CREMONA Y COMPÁS** CREMONE AND FRICTION STAY

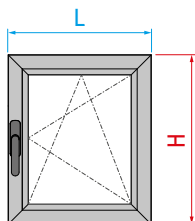

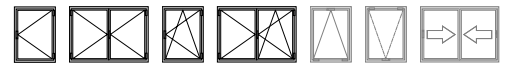

**KIT PUNTO DE CIERRE TERMINAL EVO-SOFT**  
EVO-SOFT TERMINAL LOCKING POINT KIT

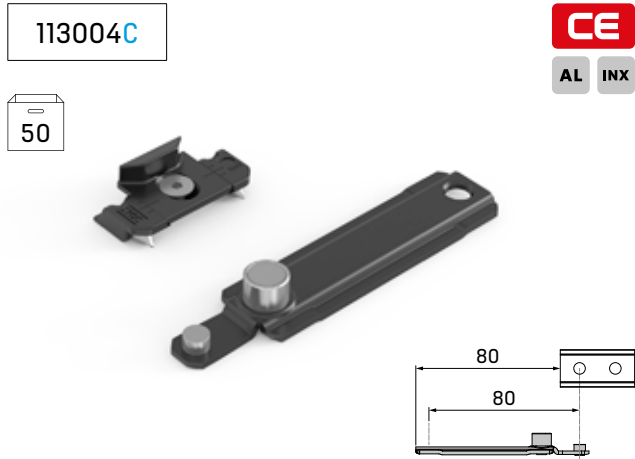

**KIT PUNTO DE CIERRE INTERMEDIO EVO-SOFT**  
EVO-SOFT INTERMEDIATE LOCKING POINT KIT

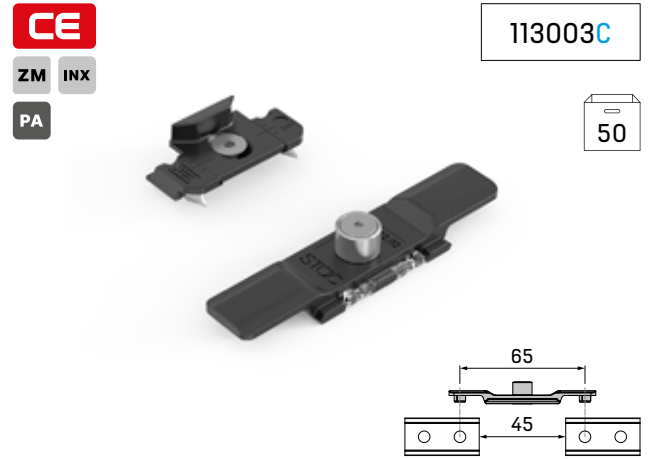

**KIT ÁNGULO DE REENVÍO SUPLEMENTARIO EVO-SOFT**  
EVO-SOFT SUPPLEMENTARY CORNER DRIVE KIT



**KIT ÁNGULO DE REENVÍO SUPLEMENTARIO EVO-SOFT**  
EVO-SOFT SUPPLEMENTARY CORNER DRIVE KIT



**KIT ÁNGULO DE REENVÍO HORIZONTAL EVO-SOFT**  
EVO-SOFT HORIZONTAL CORNER DRIVE KIT



**REMACHE EVO-SOFT**  
EVO-SOFT RIVET



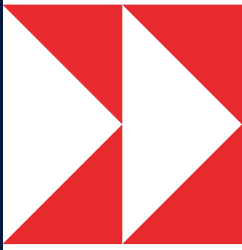

# 07

## HERRAJE EVO-SECURITY EVO-SECURITY HARDWARE



- 184 **Herraje de seguridad EVO-SECURITY**  
EVO-SECURITY safety hardware
- 186 **Kits oscilobatientes con cierre al marco**  
Tilt & turn kits with locking to frame
- 187 **Kit oscilobatiente con maniobra lógica**  
Tilt-before-turn kit
- 188 **Configuraciones de apertura oscilobatiente**  
Tilt & turn opening configurations
- 190 **Accesorios EVO-SECURITY**  
EVO-SECURITY accessories



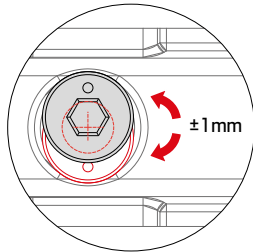

El herraje de seguridad se caracteriza por tener setas de seguridad con regulación de apriete y cerraderos antiefracción que mejoran la eficacia protegiendo contra el forzamiento, el robo y la rotura. El sistema es válido para aperturas con cierre al marco y maniobra lógica con perfil de Canal Europeo.

» Regulación por medio de punto excéntrico en forma de seta (± 1 mm)

The security hardware is characterised by having mushroom security cams that can be adjusted for tightness and anti-fraction locks that improve efficiency against forced entry, theft and breakage. The system is valid for openings with locking to frame and tilt-before-turn with Euro Groove profile.

» Adjustment by means of mushroom-shaped eccentric point (± 1 mm)

» **PUNTO DE CIERRE TERMINAL**

Punto de cierre especialmente diseñado para conectar con ángulo de reenvío, compás y fundas de transmisión.

**TERMINAL LOCKING POINT**

Locking point specially designed for connection with corner drive, friction stay and transmission cover.



» **PUNTO DE CIERRE INTERMEDIO**

Permite intercalar todos los puntos de cierre que se necesiten en configuraciones de ventana de grandes dimensiones.

**INTERMEDIATE LOCKING POINT**

The locking point allows for the insertion of locking points that are needed for window configurations in large sizes.



» **CERRADERO DE SEGURIDAD**

El cerradero incorpora un tornillo prisionero que premona directamente sobre el perfil sin necesidad de mecanizados.

**SECURITY KEEPER**

The keeper incorporates a setscrew that is pre-mounted directly on the profile without the need for machining.



» **CERRADEROS DE BASCULAMIENTO** CIERRE AL MARCO / MANIOBRA LÓGICA

Los cerraderos disponen de resbalón integrado y prisionero para el preposicionado. Incluyen la posibilidad de añadir roscachapa para mayor seguridad.

**TILT KEEPERS** LOCKING TO FRAME / TILT-BEFORE TURN

The keepers have an integrated latch and prisoner for pre-positioning. They include the possibility of adding self-tapping screws for greater security.



» **ÁNGULOS DE REENVÍO**

Los ángulos de reenvío incorporan puntos de cierre con seta de seguridad.

**CORNER DRIVES**

The corner drives incorporate locking points with mushroom security cams.



## VIVIENDA UNIFAMILIAR SINGLE-FAMILY HOME

**S1**

**Protección frente al ladrón oportunista y sin experiencia y frente a sencillos actos vandálicos con fuerza física y sin uso de herramientas.**

Protection from an inexperienced and opportunist thief and from simple acts of vandalism using physical force and non-use of tools.

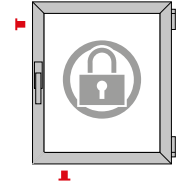

**S2**

**Protección eficaz contra delincuentes ocasionales equipados con herramientas de palanca y que no saben bien lo que pretenden conseguir. Generalmente no se arriesgan si pasan más de 3 minutos intentando forzar las ventanas.**

Efficient protection from chance delinquents equipped with lever tools who are not sure what they will achieve. Generally they will not risk more than 3 minutes of trying to force the windows.

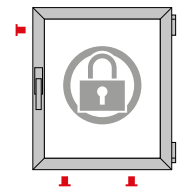

## EDIFICIOS COMERCIALES Y PÚBLICOS BUSINESS AND PUBLIC BUILDINGS

**S3**

**Protección avanzada contra delincuentes con experiencia equipados con destornilladores de grandes dimensiones y cuñas, que saben exactamente lo que quieren conseguir. Momento de ataque planificado y tiempos de ataque altos: hasta 15 minutos.**

Advanced protection from experienced delinquents that are equipped with large screwdrivers and wedges and know exactly what they want to get. Planned attack moments and increased attack times of up to 15 minutes.

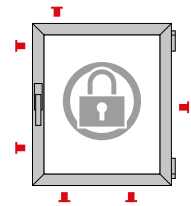

**S4**

**Protección avanzada con las mismas características que la S3 pero en ventanas y balconeras de grandes dimensiones.**

Advanced protection with the same characteristics as S3 but in large size windows and balconies.

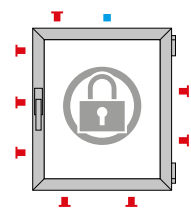

Norme  
**RC2**  
(WK2)

**Esta configuración de herraje debe ser certificada conjuntamente con el vidrio y la serie en la que va montado.**

This hardware configuration must be certified jointly with the glazing and the series that is to be assembled to.

**NOTA: para mayor seguridad se recomienda colocar el herraje EVO-SECURITY sobre fallebas de aluminio y canal de hoja simple.**

NOTE: for greater safety it is recommended to place the EVO-SECURITY hardware on aluminium operating rods and simple sash groove.

## KITS OSCIOBATIENTES CON HERRAJE EVO-SECURITY

TILT & TURN KITS WITH EVO-SECURITY HARDWARE

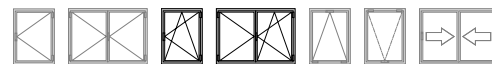

### CIERRE AL MARCO SIN CREMONA

LOCKING TO FRAME WITHOUT CREMONE

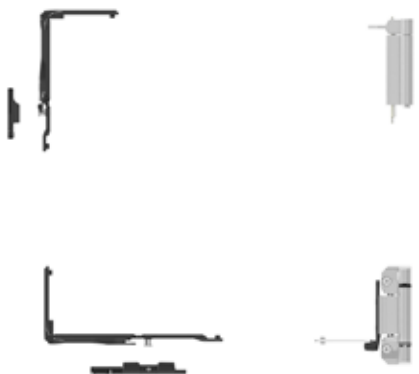
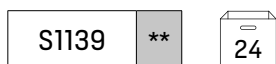

Kits diseñados para aperturas oscilobatientes de cierre al marco con puntos de cierre de seguridad.

- Los kits EVO-SECURITY vienen provistos de bisagras con regulación, ángulos de reenvío con puntos de cierre de seguridad y cerraderos especiales.
- Posibilidad de añadir múltiples puntos de cierre de seguridad.
- Todos los elementos deslizantes incorporan un clip antiholguras.
- La tornillería y las piezas metálicas están fabricadas en acero inoxidable.
- Las piezas de zamak han sido tratadas para garantizar resistencia a la corrosión de 240 horas en cámara de niebla salina de acuerdo con lo establecido en la norma UNE-EN 1670 (Grado 4).

Specially designed kits for tilt & turn openings with locking to the frame with security locking points.

- The EVO-SECURITY tilt & turn kits are supplied with adjustable hinges, corner drives with security locking points and special keepers.
- Possibility of adding multiple security locking points.
- All sliding elements are fitted with an anti-looseness clip.
- The screws and metal parts are made of stainless steel.
- The zamak parts have been treated to guarantee 240 hours of corrosion resistance in a saline mist chamber in accordance with the UNE-EN 1670 standard (Grade 4).

### CIERRE AL MARCO CON CREMONA LYRA

LOCKING TO FRAME WITH LYRA CREMONE

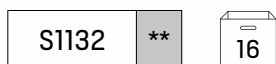

Los compases oscilobatientes no se incluyen en los kits. Consulte los compases compatibles en la página 164.

The tilt & turn friction stays are not supplied in the kits. See compatible friction stays on page 164.

### CIERRE AL MARCO CON CREMONA SIRIUS

LOCKING TO FRAME WITH SIRIUS CREMONE

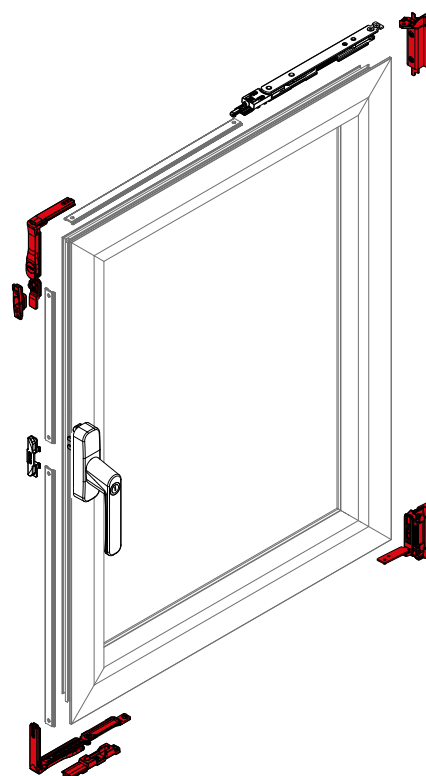
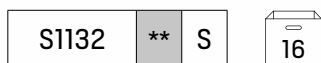



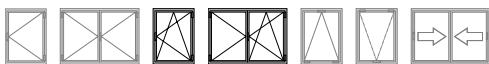

Specially designed kits for tilt & turn openings with locking to the frame with security locking points.

- The EVO-SECURITY tilt & turn kits are supplied with adjustable hinges, corner drives with security locking points and special keepers.
- Possibility of adding multiple security locking points.
- All sliding elements are fitted with an anti-looseness clip.
- The screws and metal parts are made of stainless steel.
- The zamak parts have been treated to guarantee 240 hours of corrosion resistance in a saline mist chamber in accordance with the UNE-EN 1670 standard (Grade 4).

The tilt & turn friction stays are not supplied in the kits. See compatible friction stays on page 164.

Kits diseñados para aperturas oscilobatientes de cierre al marco con puntos de cierre de seguridad.

- Los kits EVO-SECURITY vienen provistos de bisagras con regulación, ángulos de reenvío con puntos de cierre de seguridad y cerraderos especiales.
- Posibilidad de añadir múltiples puntos de cierre de seguridad.
- Todos los elementos deslizantes incorporan un clip antiholguras.
- La tornillería y las piezas metálicas están fabricadas en acero inoxidable.
- Las piezas de zamak han sido tratadas para garantizar resistencia a la corrosión de 240 horas en cámara de niebla salina de acuerdo con lo establecido en la norma UNE-EN 1670 (Grado 4).

Los compases oscilobatientes no se incluyen en los kits. Consulte los compases compatibles en la página 164.

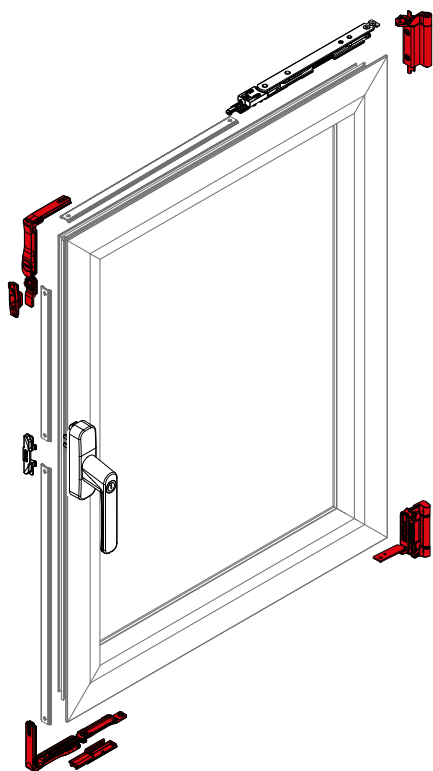

**MANIOBRA LÓGICA SIN CREMONA**  
TILT-BEFORE-TURN WITHOUT CREMONE

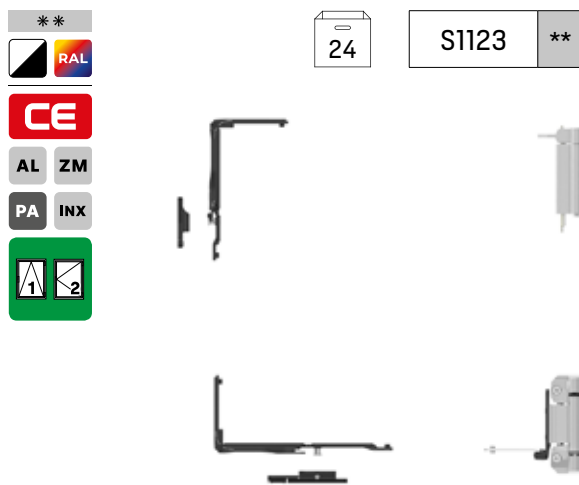

**DETALLE DE LA SETA Y PUNTO DE CIERRE DE SEGURIDAD**  
DETAIL OF THE MUSHROOM CAM AND SECURITY LOCKING POINT

# CONFIGURACIONES DE APERTURA OSCIOBATIENTE

## TILT & TURN OPENING CONFIGURATIONS

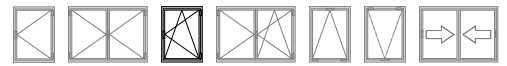

### APERTURA OSCIOBATIENTE CON HERRAJE EVO-SECURITY TILT & TURN OPENING WITH EVO-SECURITY HARDWARE



1	S1139	**	<b>KIT CIERRE AL MARCO SIN CREMONA</b> LOCKING TO FRAME KIT WITHOUT CREMONE	24
	S1123	**	<b>KIT MANIOBRA LÓGICA SIN CREMONA</b> TILT-BEFORE-TURN KIT WITHOUT CREMONE	

■ **KIT BASE** BASE KIT S1139\*\* | S1123\*\*

■ **PUNTOS DE CIERRE** LOCKING POINTS **EVO-SECURITY**

■ **COMPÁS Y CREMONA** FRICTION STAY AND CREMONE

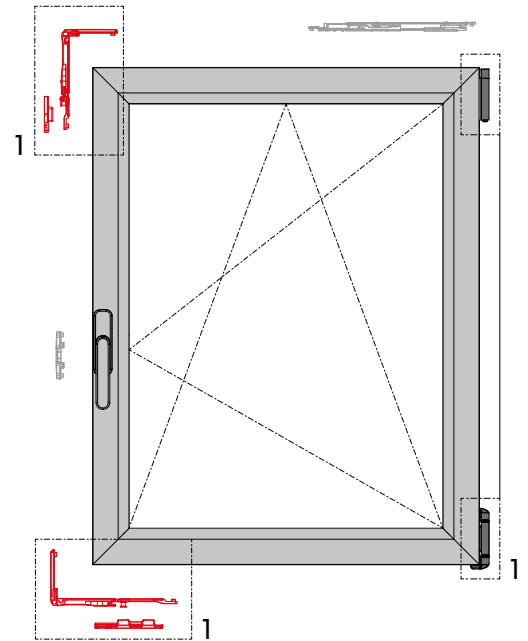

### APERTURA OSCIOBATIENTE CON HERRAJE EVO-SECURITY TILT & TURN OPENING WITH EVO-SECURITY HARDWARE



1	S1139	**	<b>KIT CIERRE AL MARCO SIN CREMONA</b> LOCKING TO FRAME KIT WITHOUT CREMONE	24
	S1123	**	<b>KIT MANIOBRA LÓGICA SIN CREMONA</b> TILT-BEFORE-TURN KIT WITHOUT CREMONE	
2	113004S		<b>KIT PUNTO DE CIERRE TERMINAL EVO-SECURITY</b> EVO-SECURITY TERMINAL LOCKING POINT KIT	50
3	0507106		<b>RESBALÓN DE POSICIONAMIENTO</b> POSITIONING LATCH	100

■ **KIT BASE** BASE KIT S1139\*\* | S1123\*\*

■ **PUNTOS DE CIERRE** LOCKING POINTS **EVO-SECURITY**

■ **COMPÁS Y CREMONA** FRICTION STAY AND CREMONE

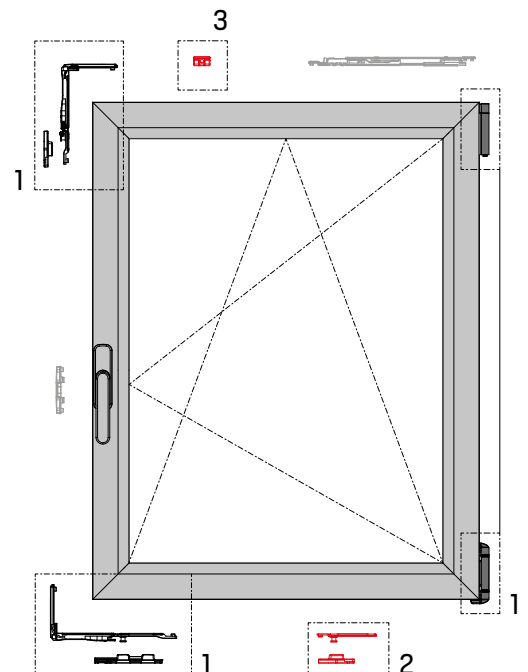

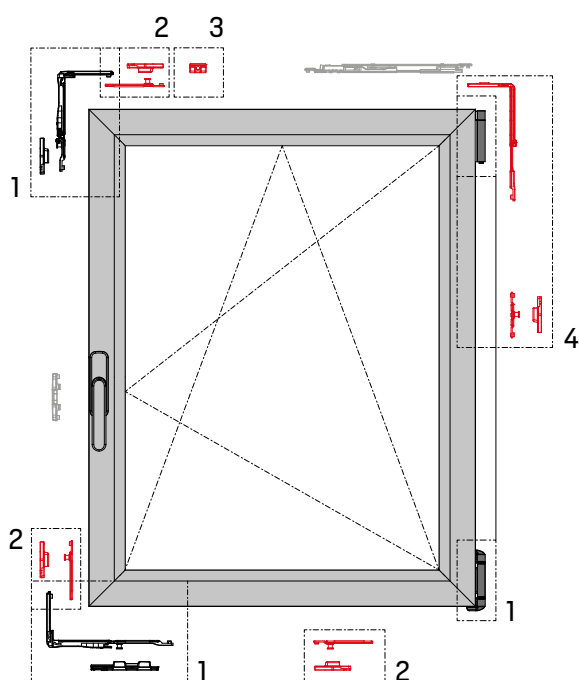

**APERTURA OSCIOBATIENTE CON HERRAJE EVO-SECURITY**  
TILT & TURN OPENING WITH EVO-SECURITY HARDWARE



1	S1139 **	<b>KIT CIERRE AL MARCO SIN CREMONA</b> LOCKING TO FRAME KIT WITHOUT CREMONE	24
1	S1123 **	<b>KIT MANIOBRA LÓGICA SIN CREMONA</b> TILT-BEFORE-TURN KIT WITHOUT CREMONE	
2	113004S	<b>KIT PUNTO DE CIERRE TERMINAL EVO-SECURITY</b> EVO-SECURITY TERMINAL LOCKING POINT KIT	50
3	0507106	<b>RESBALÓN DE POSICIONAMIENTO</b> POSITIONING LATCH	100
4	112103S	<b>KIT ÁNGULO DE REENVÍO SUPL. EVO-SECURITY</b> EVO-SECURITY SUPPLEMENTARY CORNER DRIVE KIT	20

■ **KIT BASE** BASE KIT S1139\*\* | S1123\*\*

■ **PUNTOS DE CIERRE** LOCKING POINTS EVO-SECURITY

■ **COMPÁS Y CREMONA** FRICTION STAY AND CREMONE

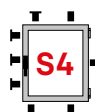
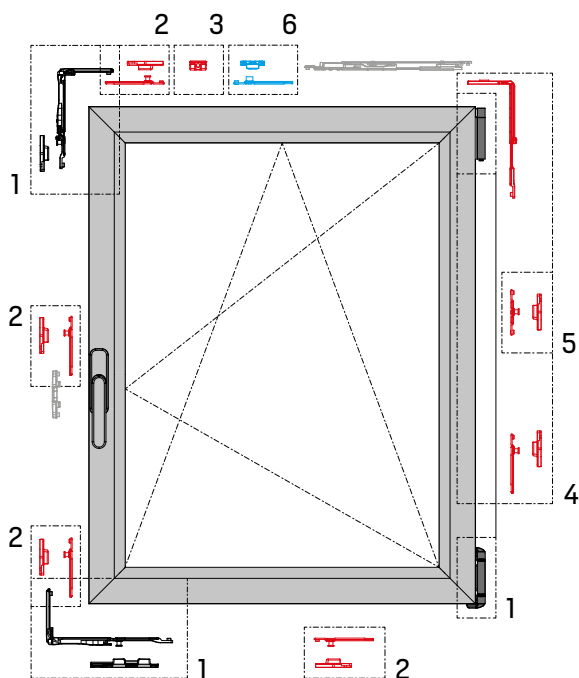

**APERTURA OSCIOBATIENTE CON HERRAJE EVO-SECURITY**  
TILT & TURN OPENING WITH EVO-SECURITY HARDWARE



1	S1139 **	<b>KIT CIERRE AL MARCO SIN CREMONA</b> LOCKING TO FRAME KIT WITHOUT CREMONE	24
1	S1123 **	<b>KIT MANIOBRA LÓGICA SIN CREMONA</b> TILT-BEFORE-TURN KIT WITHOUT CREMONE	
2	113004S	<b>KIT PUNTO DE CIERRE TERMINAL EVO-SECURITY</b> EVO-SECURITY TERMINAL LOCKING POINT KIT	50
3	0507106	<b>RESBALÓN DE POSICIONAMIENTO</b> POSITIONING LATCH	100
4	112103S	<b>KIT ÁNGULO DE REENVÍO SUPL. EVO-SECURITY</b> EVO-SECURITY SUPPLEMENTARY CORNER DRIVE KIT	20
5	113005S	<b>KIT PUNTO DE CIERRE INTERMEDIO EVO-SECURITY</b> EVO-SECURITY INTERMEDIATE LOCKING POINT KIT	50
6	113004C	<b>KIT PUNTO DE CIERRE TERMINAL EVO-SOFT</b> EVO-SOFT TERMINAL LOCKING POINT KIT	50

■ **KIT BASE** BASE KIT S1139\*\* | S1123\*\*

■ **PUNTOS DE CIERRE** LOCKING POINTS EVO-SECURITY

■ **COMPÁS Y CREMONA** FRICTION STAY AND CREMONE

■ **PUNTOS DE CIERRE** LOCKING POINTS EVO-SOFT (L > 1000 mm)

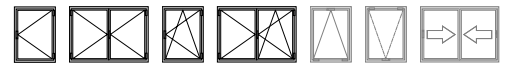

**KIT PUNTO DE CIERRE TERMINAL EVO-SECURITY**  
EVO-SECURITY TERMINAL LOCKING POINT KIT

113004S



ZM INX  
AC

50

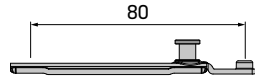

DESCUENTO DISCOUNT 80 mm

**KIT PUNTO DE CIERRE INTERMEDIO EVO-SECURITY**  
EVO-SECURITY INTERMEDIATE LOCKING POINT KIT

113005S



ZM INX  
AC

50

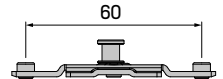

DESCUENTO DISCOUNT 40 mm

**KIT ÁNGULO DE REENVÍO SUPLEMENTARIO EVO-SECURITY**  
EVO-SECURITY SUPPLEMENTARY CORNER DRIVE KIT

A112103S



ZM INX  
AC

20



**KIT ÁNGULO DE REENVÍO SUPLEMENTARIO EVO-SECURITY**  
EVO-SECURITY SUPPLEMENTARY CORNER DRIVE KIT

B112103S



ZM INX  
AC

20



**KIT ÁNGULO DE REENVÍO HORIZONTAL EVO-SECURITY**  
EVO-SECURITY HORIZONTAL CORNER DRIVE KIT

113420S



ZM INX

20



**PUNTO DE CIERRE EVO-SECURITY**  
EVO-SECURITY LOCKING POINT

0511135



ZM INX

50



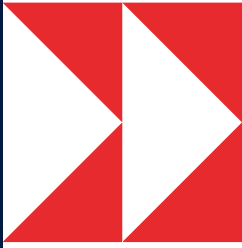

08

## HERRAJE EVO-HYBRID EVO-HYBRID HARDWARE



192

**Herraje EVO-HYBRID**  
EVO-HYBRID hardware

193

**Configuraciones de apertura oscilobatiente**  
Tilt & turn opening configurations





Sistema para aperturas oscilobatientes que aúna la seguridad que proporciona el herraje con setas de seguridad **EVO-SECURITY** y la suavidad de accionamiento del herraje encasquillado **EVO-SOFT**. El sistema es totalmente personalizable según el nivel de seguridad y suavidad del que se quiera dotar al cerramiento.

Partiendo de los kits base oscilobatientes EVO-SOFT (con casquillos) y EVO-SECURITY (con setas), se puede configurar el cerramiento más apropiado para cada vivienda, añadiendo los puntos de cierre adicionales que mejor se ajusten a lo que necesitamos.

System for tilt & turn openings which combines the safety provided by the hardware with **EVO-SECURITY** security mushrooms and the smoothness of the **EVO-SOFT** encased hardware. The system is fully customisable according to the level of security and smoothness that you want to provide the closure with.

Using the EVO-SOFT (with bushes) and EVO-SECURITY (with mushrooms) til & turn base kits, you can configure the most appropriate enclosure for each home, adding the additional locking points that best suit your needs.

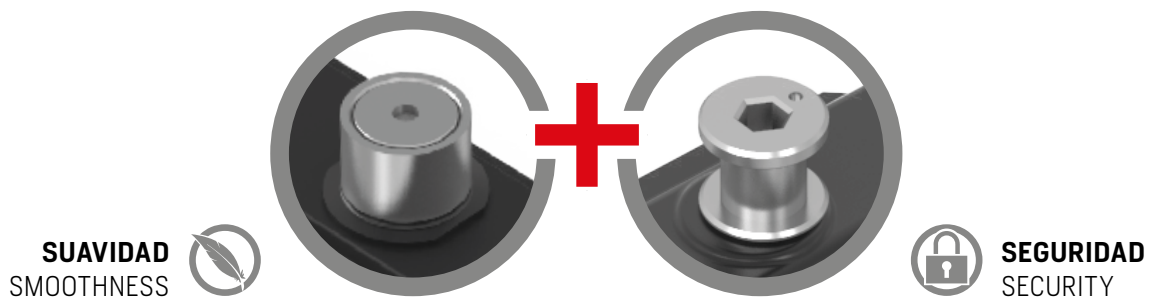

**PUNTO DE CIERRE ENCASQUILLADO**  
ENCASED LOCKING POINT



**SETA DE SEGURIDAD**  
MUSHROOM CAM LOCK



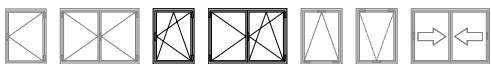

For more information, all EVO-HYBRID configurations are detailed in the STAC technical catalogues.

Para más información, todas las configuraciones EVO-HYBRID están recogidas en los catálogos técnicos STAC.

**CONFIGURACIÓN CIERRE AL MARCO DE 1 HOJA**  
SINGLE SASH LOCKING TO FRAME CONFIGURATION

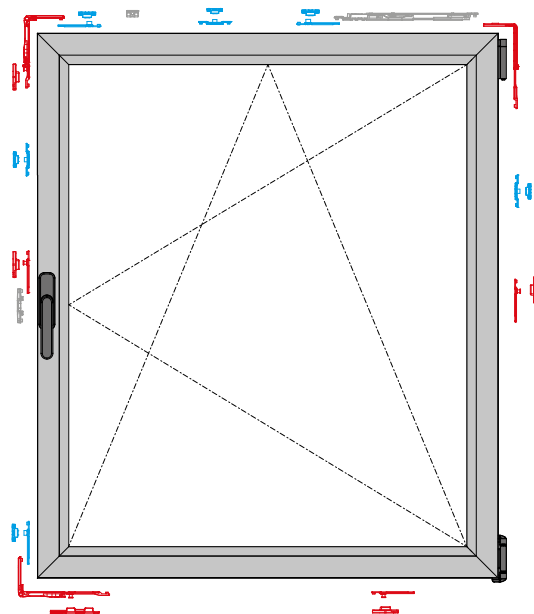

**CONFIGURACIÓN CIERRE AL MARCO DE 2 HOJAS**  
DOUBLE SASH LOCKING TO FRAME CONFIGURATION

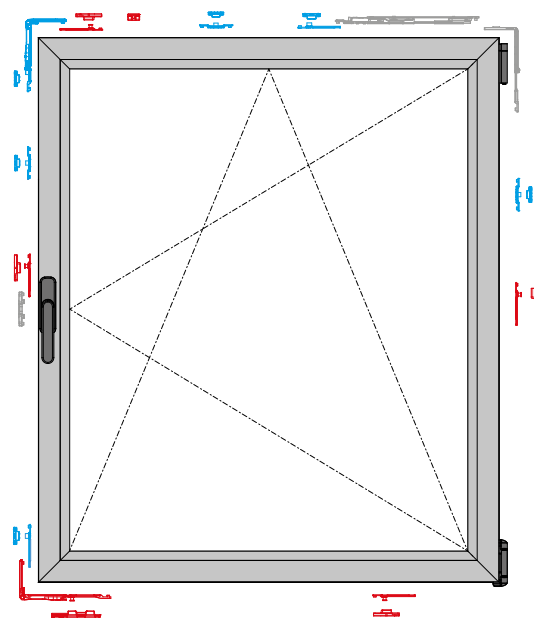
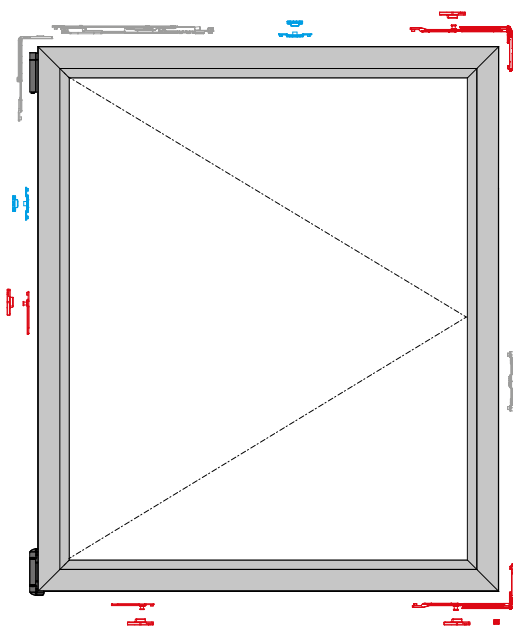

**PUNTOS DE CIERRE** LOCKING POINTS **EVO-SECURITY** ■

**PUNTOS DE CIERRE** LOCKING POINTS **EVO-SOFT** ■





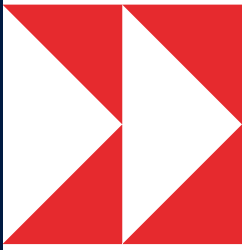

# 09

## COMPLEMENTOS ACCESSORIES

- 196 **Secuenciadores**  
Sequencers
- 198 **Puntos de cierre**  
Locking points
- 200 **Resbalones de posicionamiento**  
Positioning latches
- 200 **Cerradero regulable**  
Adjustable keeper
- 201 **Microventilación regulable**  
Adjustable micro-ventilation
- 202 **Configuraciones con microventilación**  
Micro-ventilation configurations
- 206 **Compás limitador LR para ventilación**  
LR limiting friction stay for ventilation
- 207 **Configuraciones con compás limitador LR**  
LR friction stay configurations
- 208 **Cajas de transmisión**  
Gearboxes
- 210 **Configuraciones con caja de transmisión**  
Gearbox configurations



# SECUENCIADOR DE MANIOBRA LÓGICA TILT-BEFORE-TURN SEQUENCER

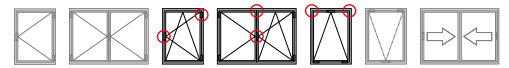

## SECUENCIADOR DE MANIOBRA LÓGICA TILT-BEFORE-TURN SEQUENCER

110220

50



Dispositivo mecánico que permite limitar las aperturas de ventanas practicable y oscilobatientes.

- Dispositivo que limita la apertura en configuración de maniobra lógica utilizando manillas sin llave.
- El secuenciador puede ser instalado en diferentes posiciones de hoja.
- El secuenciador permite un punto de cierre adicional para hojas de mayores dimensiones.
- El secuenciador es válido para sistemas oscilobatientes con limitación de apertura.
- Las piezas de zamak han sido tratadas para garantizar una resistencia a la corrosión de 240 horas en cámara de niebla salina de acuerdo con la norma UNE-EN 1670 (Grado 4).

Mechanical device that limits the opening of side-hung and tilt & turn windows.

- Device that limits the opening in a tilt-before-turn configuration using keyless handles.
- The sequencer can be installed in different sash positions.
- The tilt-before-turn sequencer allows an additional locking point on larger sashes.
- The tilt-before-turn sequence is valid for tilt & turn systems with opening limitation.
- The zamak parts have been treated to guarantee 240 hours of corrosion resistance in a salt spray chamber in accordance with the UNE-EN 1670 standard (Grade 4).



TORX 20

**EL BLOQUEO / DESBLOQUEO SE REALIZA A TRAVÉS DE LLAVE TORX20**

THE LOCKING/UNLOCKING IS DONE BY MEANS OF A TORX20 KEY

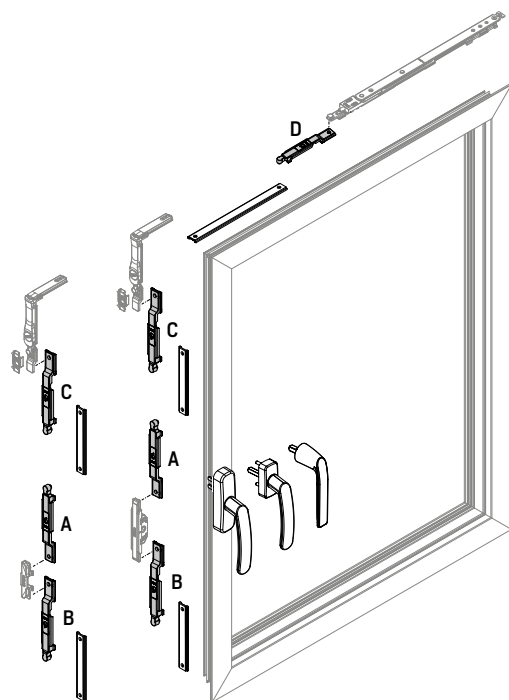
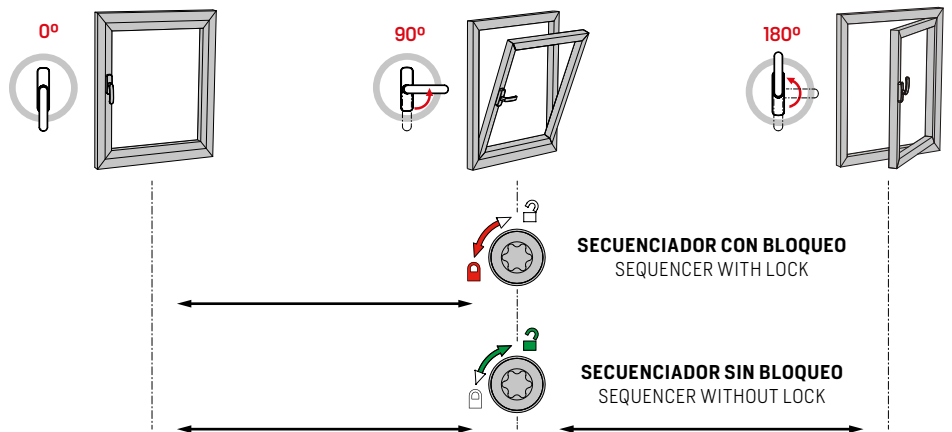

### » POSICIONES RECOMENDADAS RECOMMENDED POSITIONS

A	<b>ZONA SUPERIOR DE LA CREMONA O MANILLA</b> UPPER PART OF THE CREMONE OR HANDLE
B	<b>ZONA INFERIOR DE LA CREMONA O MANILLA</b> LOWER PART OF THE CREMONE OR HANDLE
C	<b>ACOPLADO AL ÁNGULO DE REENVÍO</b> COUPLED TO THE CORNER DRIVE
D	<b>POSICIÓN DE SEGURIDAD</b> SAFETY POSITION

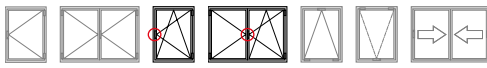

## SECUENCIADOR DE PUERTA OSCIOBATIENTE TILT & TURN DOOR SEQUENCER

A mechanical device that allows a balcony door to fully assume the functions of a door.

- The door sequencer enables a European cylinder locking system to be added to STAC's tilt & turn systems.
- The sequencer allows double handle configurations in tilt & turn systems.
- The door sequencer is valid for European cylinder with 15 mm cam.
- The sequencer is compatible with balcony door profiles that comply with minimum L = 48 mm (see diagrams).
- The use of tilt & turn kits with CLX hinges (160 kg) is recommended.

Dispositivo mecánico que permite a una puerta balconera asumir completamente las funciones de puerta.

- Permite añadir un sistema de bloqueo mediante cilindro europeo a los sistemas oscilobatientes de STAC.
- Permite configuraciones de doble manilla en sistemas oscilobatientes.
- El secuenciador es válido para cilindro europeo con leva de 15 mm.
- El secuenciador es compatible con perfiles de puerta balconera que cumplan con L min = 48 mm (ver esquemas).
- Se recomienda el uso de kits oscilobatientes con bisagras CLX (160 kg).

Cylinder and cylinder covers are not included in the references 110230 / 110231.

No se incluyen ni cilindro ni embellecedores en las referencias.

## SECUENCIADOR DE PUERTA OSCIOBATIENTE TILT & TURN DOOR SEQUENCER



ZM INX



+ PH2

allen4

Cierre al marco  
Locking to frame

110230

Cierre al inversor  
Locking to inverter

110231



50

## DESCONECTOR DE HERRAJE HARDWARE DISCONNECTOR

ZM

110212



25

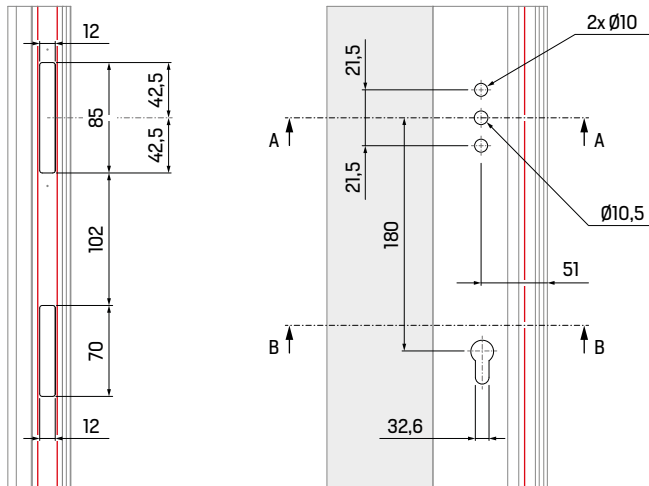

CANAL DEL PERFIL  
PROFILE GROOVE

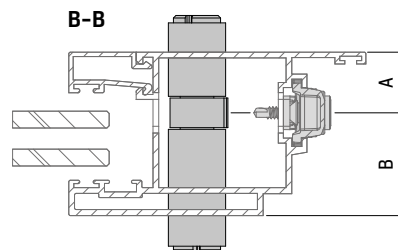
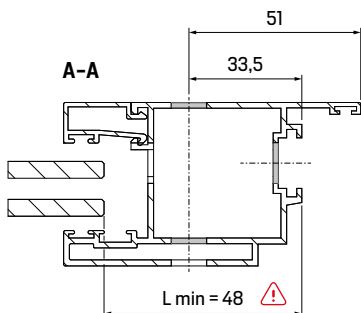

### » EMBELLECEDORES CYLINDER COVERS

0508053	**	SLIM	X = 6,2 mm
0508029	**	SIRIUS	X = 8,7 mm
0508028	**	GÉMINIS	X = 10 mm

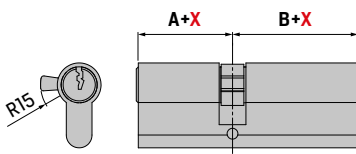

### » DESCUENTOS HARDWARE DISCOUNTS

#### CIERRE AL INVERSOR LOCKING TO THE INVERTER

A2 H - C - 249

A1 C - 364

#### CIERRE AL MARCO LOCKING TO THE FRAME

A2 H - C - 249

A1 C - 266

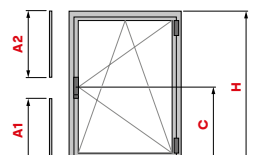

## PUNTOS DE CIERRE

LOCKING POINTS

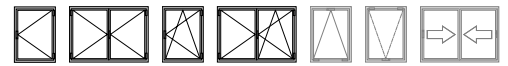

### PUNTO DE CIERRE PARA EL INVERSOR

LOCKING POINT FOR THE INVERTER

110210

100



Puntos de cierre para sistemas con series de perfil con Canal Europeo.

Locking points for systems with Euro Groove profile series.

#### Punto de cierre para el inversor

- Elemento de inversor para punto de cierre con regulación de apriete.
- Se recomienda su uso para espesores de pestaña menores de 1,8 mm.

#### Locking point for the inverter

- Inverter element for locking point with tightening adjustment.
- Recommended for flange thickness less than 1.8 mm.

#### Punto de cierre regulable

- Elemento de marco para punto de cierre con regulación de apriete.

#### Adjustable locking point

- Frame element for locking point with tightening adjustment.

#### Punto de cierre oculto

- Punto de cierre suplementario para hojas de apertura practicable.
- Se recomienda su uso a partir de 1200 mm de altura de la hoja.

#### Concealed locking point

- Supplementary locking point for side-hung window sashes.
- Recommended for use from 1200 mm sash height.

### PUNTO DE CIERRE REGULABLE

ADJUSTABLE LOCKING POINT

110200

500



#### Kit punto de cierre suplementario

- Kit compuesto por un cerradero regulable y un punto de cierre deslizador que funcionan como cierre suplementario.

#### Supplementary locking point kit

- Kit consisting of an adjustable keeper and a sliding locking point that acts as a supplementary locking point.

### PUNTO DE CIERRE OCULTO

CONCEALED LOCKING POINT

112500

50

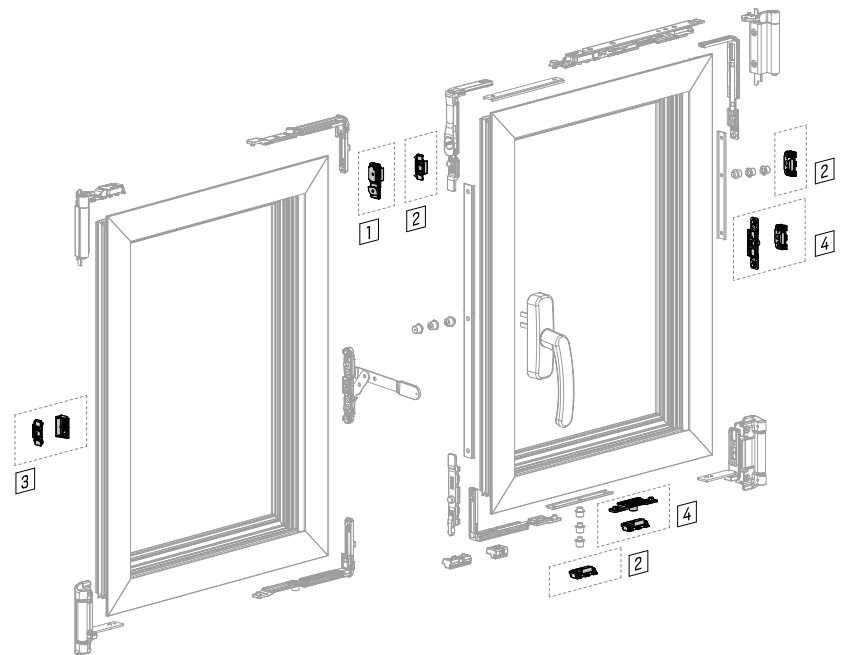

### KIT PUNTO DE CIERRE SUPLEMENTARIO

SUPPLEMENTARY LOCKING POINT KIT

113000IM

50



REF.

DESCRIPCIÓN DESCRIPTION



REF.	DESCRIPCIÓN	DESCRIPTION	
1	<b>110210</b>	<b>PUNTO DE CIERRE PARA EL INVERSOR</b> LOCKING POINT FOR THE INVERTER	100
2	<b>110200</b>	<b>PUNTO DE CIERRE REGULABLE</b> ADJUSTABLE LOCKING POINT	500
3	<b>112500</b>	<b>PUNTO DE CIERRE OCULTO</b> HIDDEN LOCKING POINT	50
4	<b>113000IM</b>	<b>KIT PUNTO DE CIERRE SUPLEMENTARIO</b> SUPPLEMENTARY LOCKING POINT KIT	50

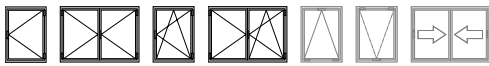

## PUNTOS DE CIERRE LOCKING POINTS

The rivets act as locking points for systems with profile series with Euro Groove or Groove 16.

- They make it possible to obtain a locking point anywhere a transmission rod passes without cutting it.
- The rivets allow to replace the transmission cover, so that the blade of the cremone acts directly on the locking points.
- The locking points can be riveted with STAC TFS die-cutting machines.

Los remaches hacen la función de puntos de cierre para sistemas con series de perfil con Canal Europeo o Canal 16.

- Permiten obtener un punto de cierre en cualquier lugar por el que pase una falleba sin necesidad de cortarla.
- Los remaches permiten sustituir a la funda de transmisión, de esta forma la pala de la cremona actúa directamente sobre los puntos de cierre.
- Pueden ser remachado con las máquinas troqueladoras TFS de STAC.

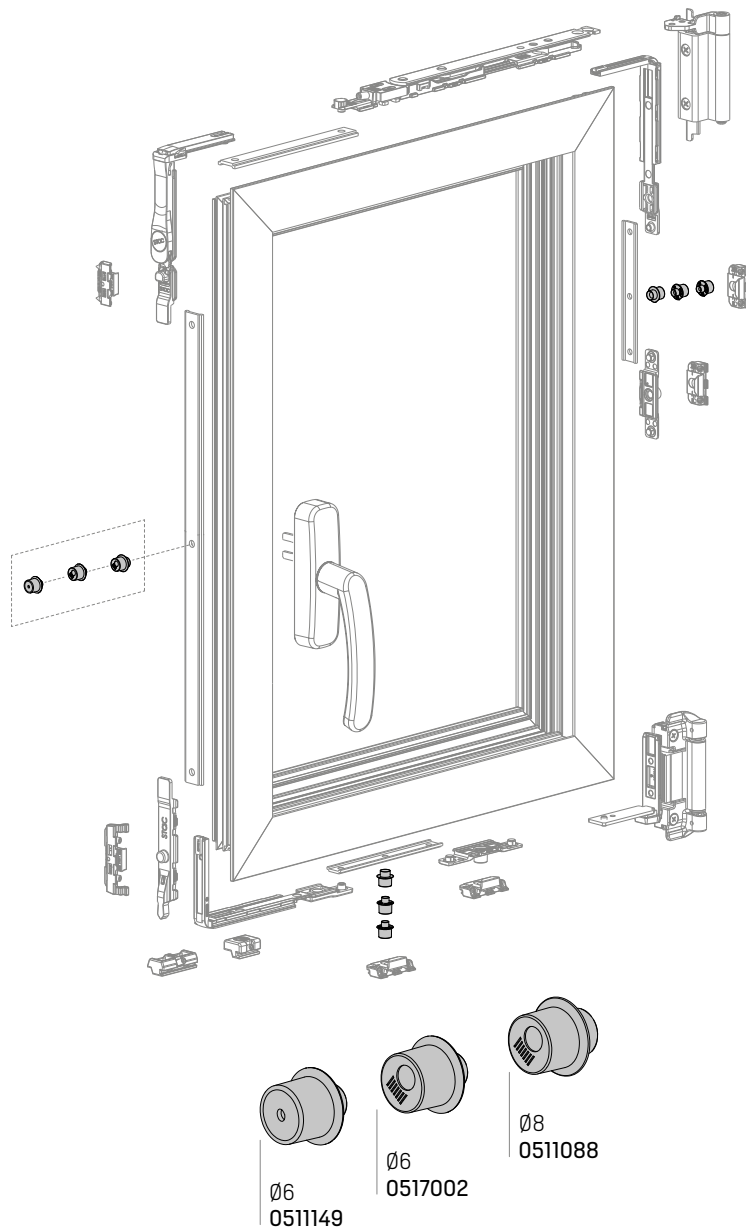

### REMACHE Ø8 Ø8 RIVET



0511088

50



### REMACHE Ø6 Ø6 RIVET



0517002

50



### REMACHE EVO-SOFT Ø6 Ø6 EVO-SOFT RIVET



0511149

50



## RESBALONES DE POSICIONAMIENTO

### POSITIONING LATCHES

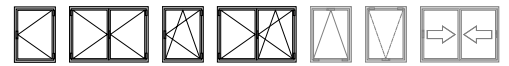

### KIT RESBALÓN DE POSICIONAMIENTO

#### POSITIONING LATCH KIT

0710621

100



Resbalones de posicionamiento y cerradero regulable para aperturas practicable y oscilobatientes.

#### Resbalón de posicionamiento

- Facilita el posicionamiento de la hoja en el momento de cerrar la ventana.

#### Cerradero regulable

- Elemento de marco que permite regulación de apriete.
- Posee un ranurado antideslizamiento que permite la regulación progresiva.

Positioning latches and adjustable keeper for side-hung and tilt & turn window openings.

#### Positioning latch

- It makes it easier to position the sash when closing the window.

#### Adjustable keeper

- Frame element that allows tightening adjustment.
- The keeper has an anti-slip groove that allows progressive adjustment.

### RESBALÓN DE POSICIONAMIENTO

#### POSITIONING LATCH

0517193

100

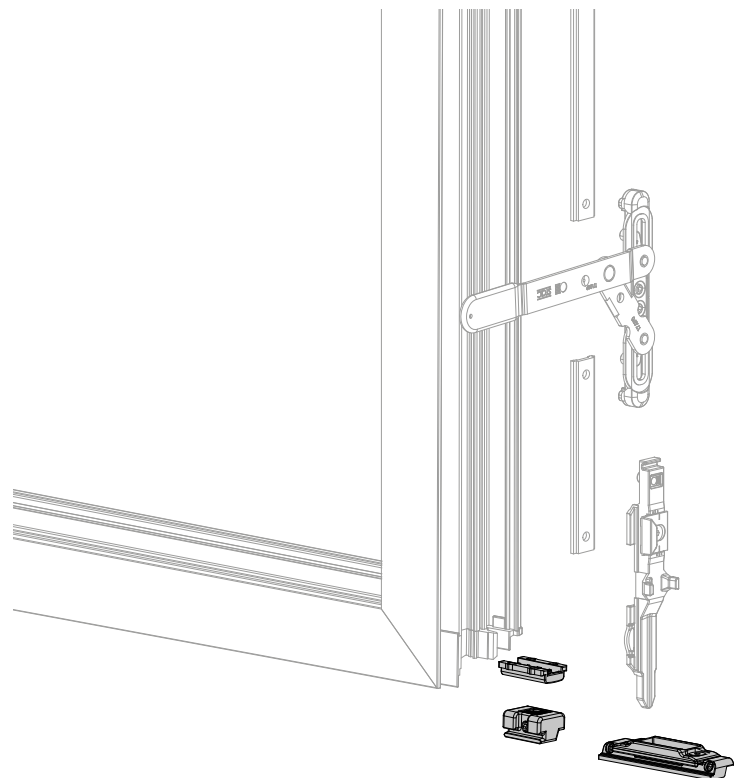

### CERRADERO DOBLE REGULABLE DE ZAMAK

#### ZAMAK DOUBLE ADJUSTABLE KEEPER

110501

200

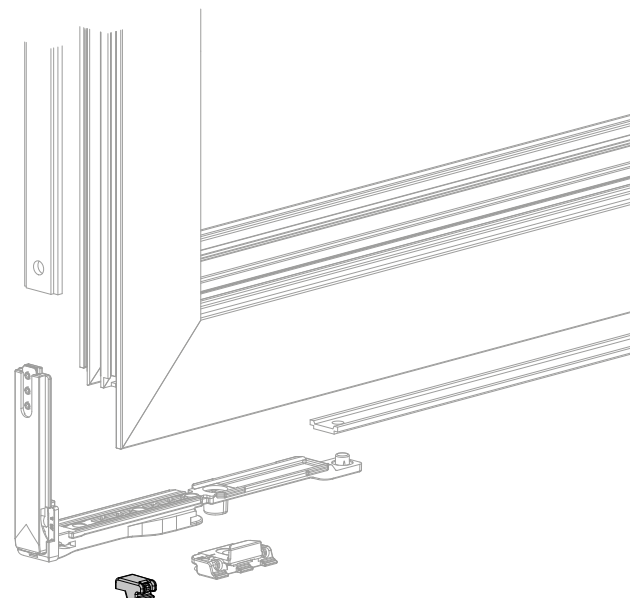

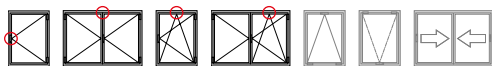

Device that allows an aeration position in the window.

- The device can be used for both side-hung and tilt & turn window openings.
- The design of the keeper makes that when turning the handle or cremone the sash is open between 1 and 6 mm.
- The mechanism complies with all the requirements of the Technical Building Code regarding indoor air quality, guaranteeing the required ventilation.

**Tests (Class 1)**

- Air permeability according to the UNE-EN 12207: 2017 standard in the micro-opening position.
- Values obtained in accordance with the UNE-EN 1026: 2017 standard by notified body 2242 in accordance with report number PR110009. \*

\* Reference sample: double sash window 1246 x 1500 mm.

Dispositivo que permite una posición de aireación en la ventana.

- El dispositivo es aplicable en ventanas practicables como oscilobatientes.
- El diseño del cerradero hace que al girar la manilla o la cremone, la hoja quede abierta entre 1 y 6 mm.
- El dispositivo cumple con todas las exigencias del Código Técnico de Edificación en cuanto a calidad del aire interior, garantizando la ventilación exigida.

**Ensayos (Clase 1)**

- Permeabilidad al aire según la norma UNE-EN 12207: 2017 en posición de microapertura.
- Valores obtenidos según la norma UNE-EN 1026: 2017 realizada en organismo notificado 2242 de acuerdo con el número de informe PR110009. \*

\* Muestra de referencia: ventana 2 hojas 1246 x 1500 mm.

**MICROVENTILACIÓN REGULABLE**  
ADJUSTABLE MICRO-VENTILATION



A114401

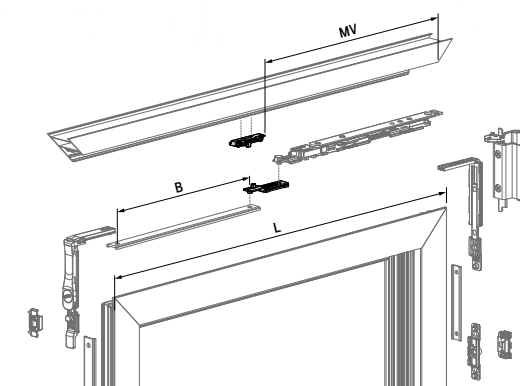
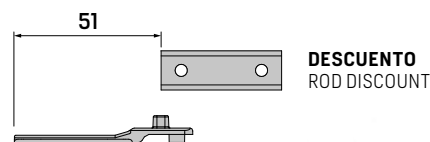

» **DESCUENTOS PARA MICROVENTILACIÓN** MICRO-VENTILATION DISCOUNTS

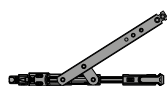

110309	<b>MICRO</b>	435	307	L-360
B110302	<b>PEQUEÑO</b> SMALL	496	371	L-424
B110301	<b>GRANDE</b> LARGE	618	493	L-546
T110301	<b>GRANDE CLX</b> CLX LARGE	618	493	L-546
B110301 + A130301	<b>GRANDE + SUPLEMENTARIO</b> LARGE + SUPPLEMENTARY	1000	493	L-646
T110301 + A130301	<b>GRANDE CLX + SUPLEMENTARIO</b> CLX LARGE + SUPPLEMENTARY	1000	493	L-646
H1213R1_L1	<b>CH180+ GRANDE</b> CH180+ LARGE	638	490	L-567
H1213R3_L3	<b>CH180+ PEQUEÑO</b> CH180+ SMALL	518	406	L-483
H1213R1_L1 + A130301	<b>CH180+ + SUPLEMENTARIO</b> CH180+ + SUPPLEMENTARY	1000	490	L-667

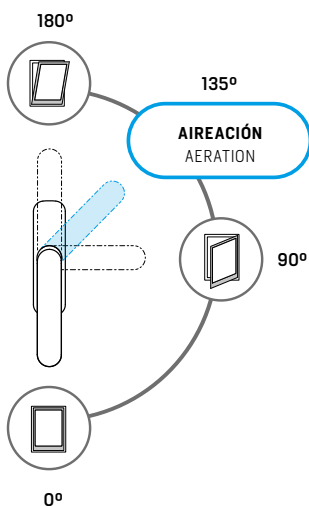

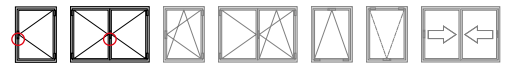

### APERTURA PRACTICABLE CON FUNDA DE TRANSMISIÓN

SIDE-HUNG OPENING WITH TRANSMISSION COVER

#### CIERRE AL INVERSOR

LOCKING TO THE INVERTER



1	<b>CREMONA CON FUNDA DE TRANSMISIÓN</b>		
	CREMONE WITH TRANSMISSION COVER		
2	<b>A114401 MICROVENTILACIÓN REGULABLE</b>		100
	ADJUSTABLE MICRO-VENTILATION		
3	<b>113000IM KIT PUNTO DE CIERRE SUPLEMENTARIO</b>		50
	SUPPLEMENTARY LOCKING POINT KIT		
4	<b>110200 PUNTO DE CIERRE REGULABLE</b>		500
	ADJUSTABLE LOCKING POINT		
5	<b>0710621 KIT RESBALÓN DE POSICIONAMIENTO</b>		100
	POSITIONING LATCH KIT		

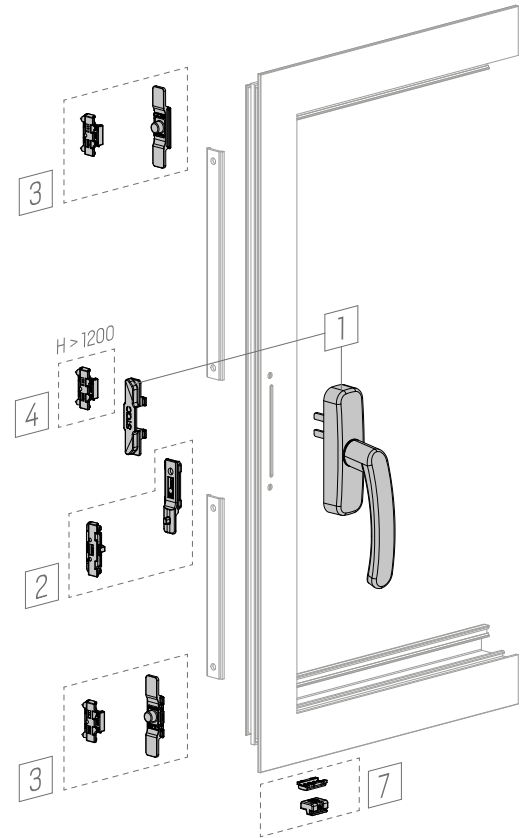

#### CIERRE AL MARCO CON ÁNGULO DE REENVIO Y PUNTERO

LOCKING TO THE FRAME WITH CORNER DRIVE AND POINTER



1	<b>CREMONA CON FUNDA DE TRANSMISIÓN</b>		
	CREMONE WITH TRANSMISSION COVER		
2	<b>A114401 MICROVENTILACIÓN REGULABLE</b>		100
	ADJUSTABLE MICRO-VENTILATION		
3	<b>113000IM KIT PUNTO DE CIERRE SUPLEMENTARIO</b>		50
	SUPPLEMENTARY LOCKING POINT KIT		
4	<b>113420 KIT ÁNGULO DE REENVIO HORIZONTAL</b>		20
	HORIZONTAL CORNER DRIVE KIT		
5	<b>0517193 RESBALÓN DE POSICIONAMIENTO</b>		100
	POSITIONING LATCH		
6	<b>110200 PUNTO DE CIERRE REGULABLE</b>		500
	ADJUSTABLE LOCKING POINT		
7	<b>07085 PUNTERO Ø6 PARA APERTURA PRACTICABLE</b>		1000
	SIDE-HUNG OPENING Ø6 POINTER		
8	<b>0507105 CERRADERO</b>		50
	KEEPER		

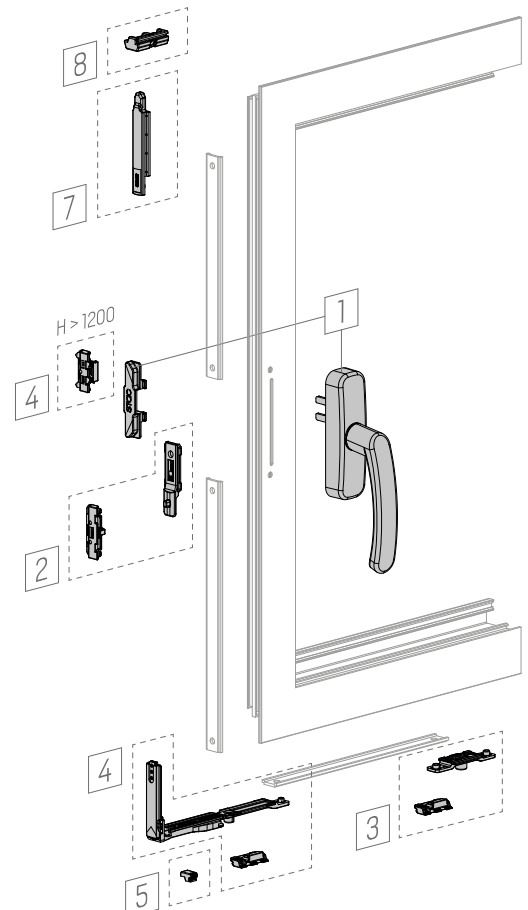





**APERTURA PRACTICABLE CON FUNDA DE TRANSMISIÓN**  
SIDE-HUNG OPENING WITH TRANSMISSION COVER



**CIERRE AL MARCO CON DOBLE ÁNGULO DE REENVIO**  
LOCKING TO THE FRAME WITH DOUBLE CORNER DRIVE



1	<b>CREMONA CON FUNDA DE TRANSMISIÓN</b> CREMONE WITH TRANSMISSION COVER	
2	<b>A114401 MICROVENTILACIÓN REGULABLE</b> ADJUSTABLE MICRO-VENTILATION	100
3	<b>113000IM KIT PUNTO DE CIERRE SUPLEMENTARIO</b> SUPPLEMENTARY LOCKING POINT KIT	50
4	<b>113420 KIT ÁNGULO DE REENVIO HORIZONTAL</b> HORIZONTAL CORNER DRIVE KIT	20
5	<b>0517193 RESBALÓN DE POSICIONAMIENTO</b> POSITIONING LATCH	100
6	<b>110200 PUNTO DE CIERRE REGULABLE</b> ADJUSTABLE LOCKING POINT	500

Single sash configuration **Configuración de 1 hoja**

**CIERRE AL MARCO CON DOBLE ÁNGULO DE REENVIO**  
LOCKING TO THE FRAME WITH DOUBLE CORNER DRIVE



1	<b>CREMONA CON FUNDA DE TRANSMISIÓN</b> CREMONE WITH TRANSMISSION COVER	
2	<b>A114401 MICROVENTILACIÓN REGULABLE</b> ADJUSTABLE MICRO-VENTILATION	100
3	<b>113000IM KIT PUNTO DE CIERRE SUPLEMENTARIO</b> SUPPLEMENTARY LOCKING POINT KIT	50
4	<b>113420 KIT ÁNGULO DE REENVIO HORIZONTAL</b> HORIZONTAL CORNER DRIVE KIT	20
5	<b>0517193 RESBALÓN DE POSICIONAMIENTO</b> POSITIONING LATCH	100
6	<b>110200 PUNTO DE CIERRE REGULABLE</b> ADJUSTABLE LOCKING POINT	500
7	<b>A113800 KIT PASADORES DE PALANCA</b> SHOOTBOLT LEVER KIT	20

Double sash configuration **Configuración de doble hoja**

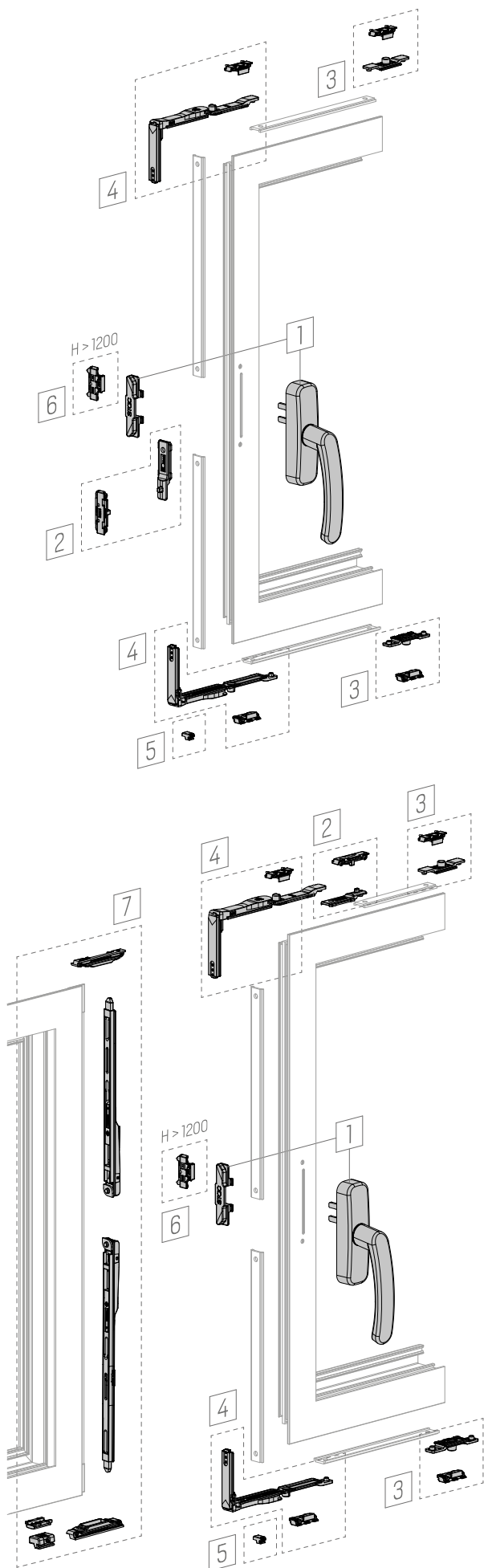



APERTURA PRACTICABLE CON CAJA DE TRANSMISIÓN

SIDE-HUNG OPENING WITH GEARBOX

CIERRE AL INVERSOR

LOCKING TO THE INVERTER



1	<b>MANILLA</b> HANDLE		
2	<b>A114401</b> <b>MICROVENTILACIÓN REGULABLE</b> ADJUSTABLE MICRO-VENTILATION	100	
3	<b>113000IM</b> <b>KIT PUNTO DE CIERRE SUPLEMENTARIO</b> SUPPLEMENTARY LOCKING POINT KIT	50	
4	<b>0507063</b> <b>CAJA DE TRANSMISIÓN</b> GEARBOX	50	
5	<b>110200</b> <b>PUNTO DE CIERRE REGULABLE</b> ADJUSTABLE LOCKING POINT	500	
6	<b>0517002</b> <b>PUNTO DE CIERRE: REMACHE Ø6</b> LOCKING POINT: RIVET Ø6	50	
7	<b>0710621</b> <b>KIT RESBALÓN DE POSICIONAMIENTO</b> POSITIONING LATCH KIT	100	

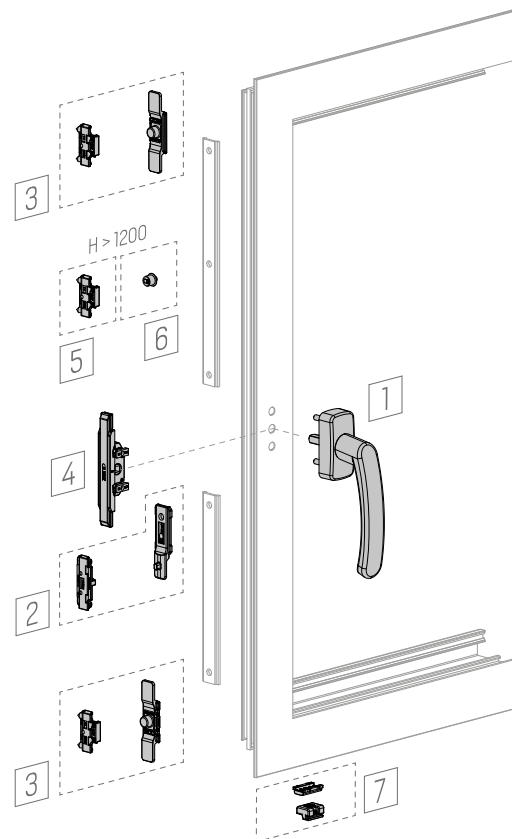

CIERRE AL MARCO CON ÁNGULO DE REENVIO Y PUNTERO

LOCKING TO THE FRAME WITH CORNER DRIVE AND POINTER



1	<b>MANILLA</b> HANDLE		
2	<b>A114401</b> <b>MICROVENTILACIÓN REGULABLE</b> ADJUSTABLE MICRO-VENTILATION	100	
3	<b>113000IM</b> <b>KIT PUNTO DE CIERRE SUPLEMENTARIO</b> SUPPLEMENTARY LOCKING POINT KIT	50	
4	<b>113420</b> <b>KIT ÁNGULO DE REENVIO HORIZONTAL</b> HORIZONTAL CORNER DRIVE KIT	20	
5	<b>0517193</b> <b>RESBALÓN DE POSICIONAMIENTO</b> POSITIONING LATCH	100	
6	<b>0507063</b> <b>CAJA DE TRANSMISIÓN</b> GEARBOX	50	
7	<b>07085</b> <b>PUNTERO Ø6 PARA APERTURA PRACTICABLE</b> SIDE-HUNG OPENING Ø6 POINTER	1000	
8	<b>0507105</b> <b>CERRADERO</b> KEEPER	50	
9	<b>110200</b> <b>PUNTO DE CIERRE REGULABLE</b> ADJUSTABLE LOCKING POINT	500	
10	<b>0517002</b> <b>PUNTO DE CIERRE: REMACHE Ø6</b> LOCKING POINT: RIVET Ø6	50	

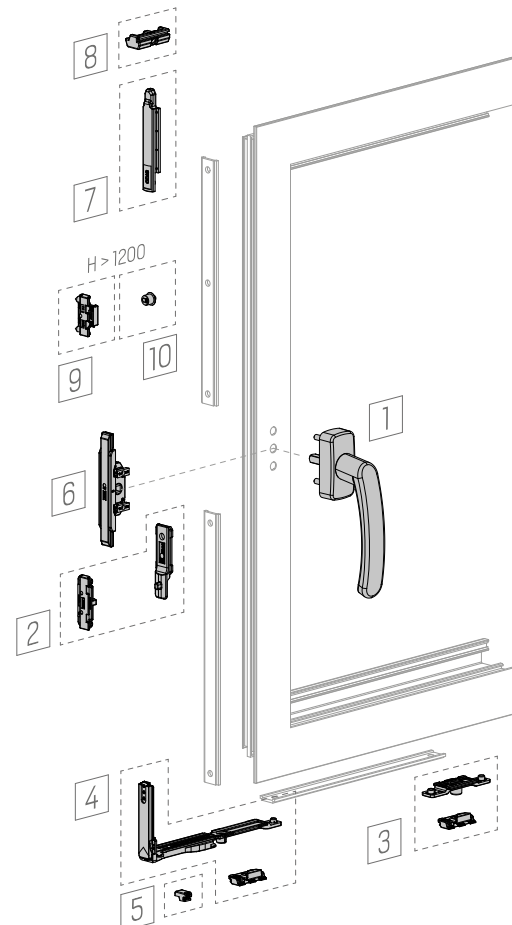



**APERTURA PRACTICABLE CON CAJA DE TRANSMISIÓN**  
SIDE-HUNG OPENING WITH GEARBOX



**CIERRE AL MARCO CON DOBLE ÁNGULO DE REENVIO**  
LOCKING TO THE FRAME WITH DOUBLE CORNER DRIVE



1	<b>MANILLA</b> HANDLE		
2	<b>A114401 MICROVENTILACIÓN REGULABLE</b> ADJUSTABLE MICRO-VENTILATION		100
3	<b>113000IM KIT PUNTO DE CIERRE SUPLEMENTARIO</b> SUPPLEMENTARY LOCKING POINT KIT		50
4	<b>113420 KIT ÁNGULO DE REENVIO HORIZONTAL</b> HORIZONTAL CORNER DRIVE KIT		20
5	<b>0517193 RESBALÓN DE POSICIONAMIENTO</b> POSTIONING LATCH		100
6	<b>0507063 CAJA DE TRANSMISIÓN</b> GEARBOX		50
7	<b>110200 PUNTO DE CIERRE REGULABLE</b> ADJUSTABLE LOCKING POINT		500
8	<b>0517002 PUNTO DE CIERRE: REMACHE Ø6</b> LOCKING POINT: RIVET Ø6		50

Single sash configuration **Configuración de 1 hoja**

**CIERRE AL MARCO CON DOBLE ÁNGULO DE REENVIO**  
LOCKING TO THE FRAME WITH DOUBLE CORNER DRIVE



1	<b>MANILLA</b> HANDLE		
2	<b>A114401 MICROVENTILACIÓN REGULABLE</b> ADJUSTABLE MICRO-VENTILATION		100
3	<b>113000IM KIT PUNTO DE CIERRE SUPLEMENTARIO</b> SUPPLEMENTARY LOCKING POINT KIT		50
4	<b>113420 KIT ÁNGULO DE REENVIO HORIZONTAL</b> HORIZONTAL CORNER DRIVE KIT		20
5	<b>0517193 RESBALÓN DE POSICIONAMIENTO</b> POSTIONING LATCH		100
6	<b>0507063 CAJA DE TRANSMISIÓN</b> GEARBOX		50
7	<b>110200 PUNTO DE CIERRE REGULABLE</b> ADJUSTABLE LOCKING POINT		500
8	<b>0517002 PUNTO DE CIERRE: REMACHE Ø6</b> LOCKING POINT: RIVET Ø6		50
9	<b>A113800 KIT PASADORES DE PALANCA</b> SHOOTBOLT LEVER KIT		20

Double sash configuration **Configuración de doble hoja**

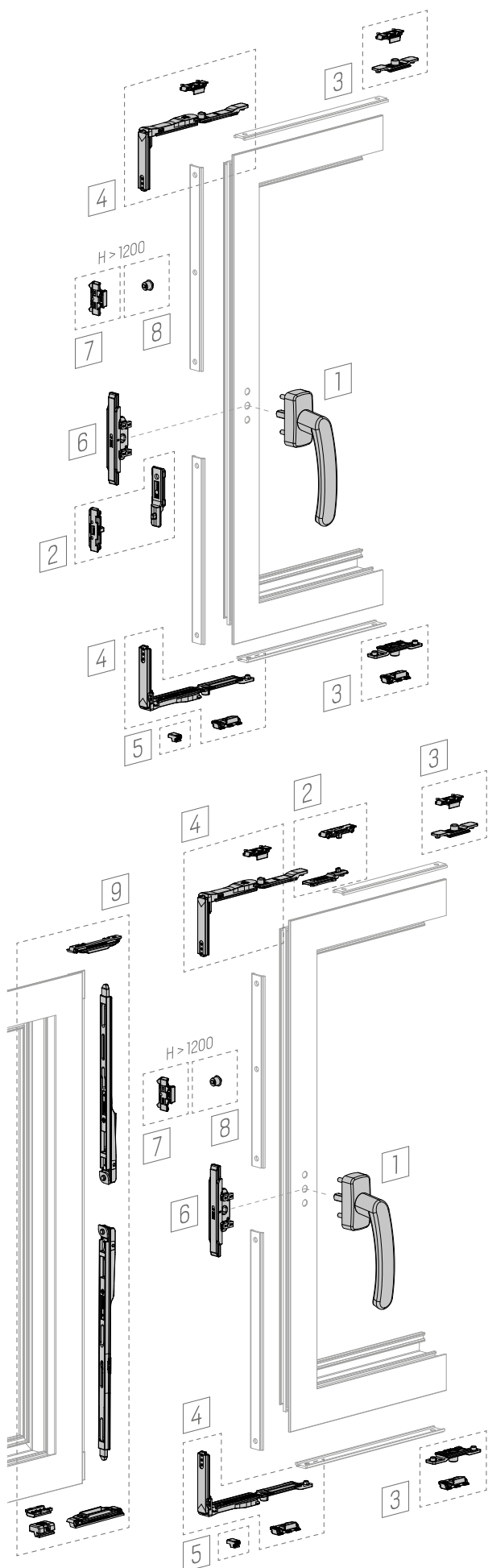

## COMPÁS LIMITADOR PARA VENTILACIÓN LIMITING FRICTION STAY FOR VENTILATION

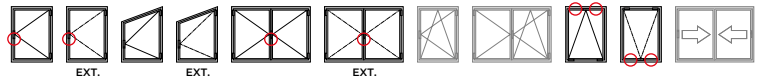

### COMPÁS LIMITADOR LR PARA VENTILACIÓN LR LIMITING FRICTION STAY WITH RETENTION

130110

**Descuento de la falleba 100 mm**  
Rod discount 100 mm

15



Compás limitador LR que permite configurar posiciones estables de ventilación en ventanas practicables.

- La posición de ventilación de la ventana practicable se realiza a través de un resorte de retención.
- El compás LR permite una posición de apertura con uso restringido.
- Facilidad de regulación de la apertura de la ventana para ventilación.
- Rapidez de montaje. Pre-montaje directo en hoja y marco.
- El compás permite la fijación adicional por medio de tornillos rosca-chapa.
- Múltiples posibilidades de instalación.

LR limiting friction stay for setting stable ventilation positions in side-hung opening windows.

- The ventilation position of the side-hung window is set by means of a locking spring.
- The LR restrictor friction stay allows an open position with restricted use.
- Easy adjustment of the window opening for ventilation.
- Quick assembly. Pre-assembly directly on sash and frame.
- The friction stay allows additional fixing by means of self-tapping screws.
- Multiple installation possibilities.

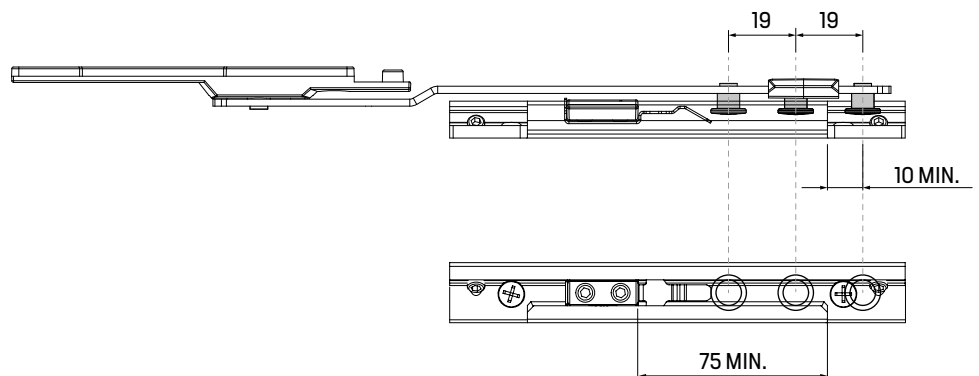
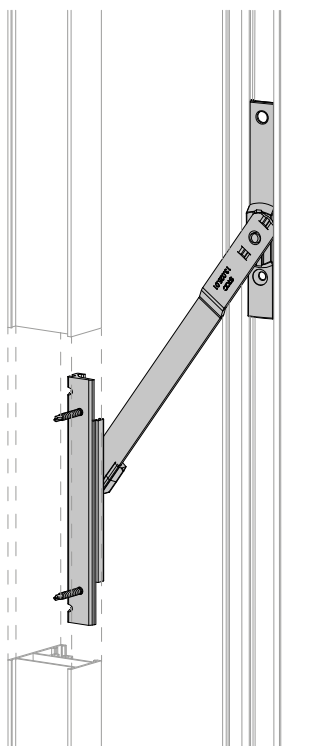
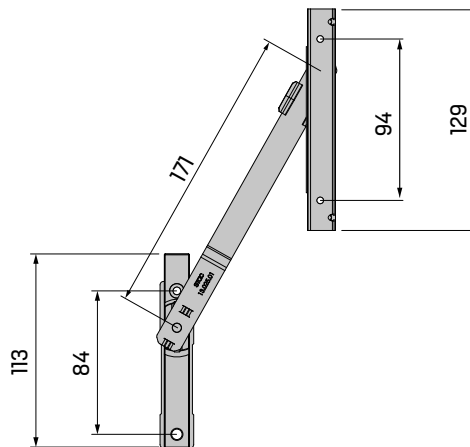

■ **APERTURA ABATIBLE**  
 BOTTOM-HUNG OPENING

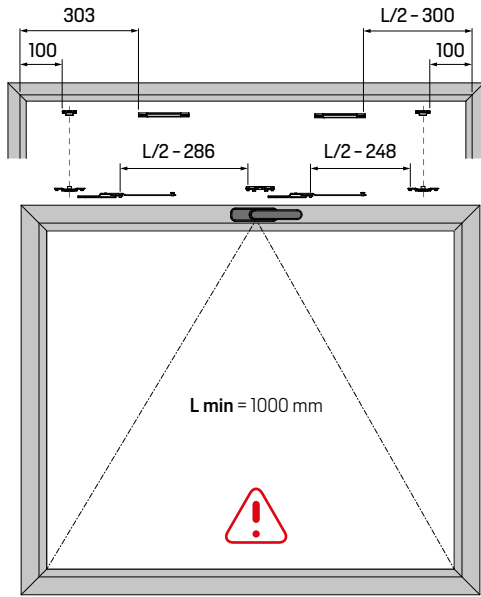

■ **APERTURA ABATIBLE CON TRANSMISIÓN LATERAL**  
 BOTTOM-HUNG OPENING WITH LATERAL TRANSMISSION

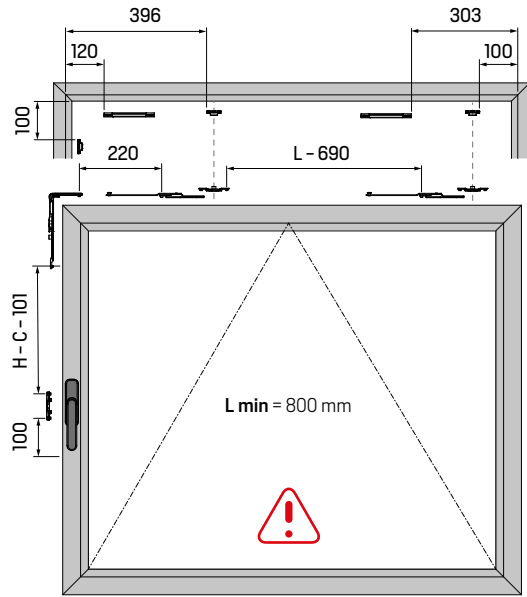

■ **APERTURA PRACTICABLE**  
 SIDE-HUNG OPENING

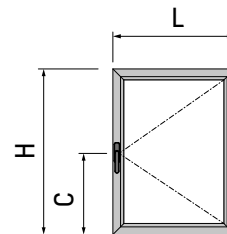
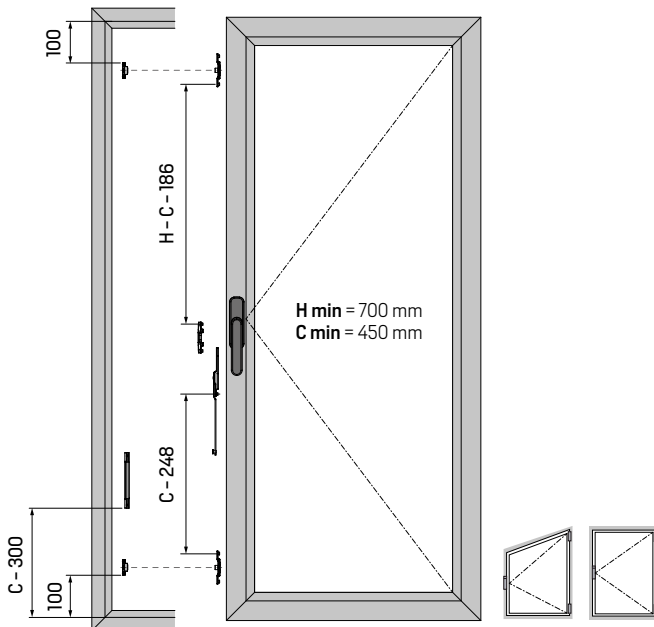

Por razones de seguridad, en áreas públicas la instalación de limitadores es obligatoria a partir de 40 kg. Compases limitadores en páginas 233- 237.  
 For safety reasons, in public areas the installation of limiters is compulsory from 40 kg. Restrictor friction stays on pages 233- 237.

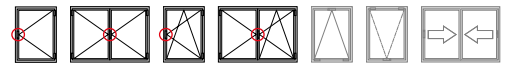

**MONODIRECCIONAL Aguja 7 mm**  
ONE-WAY Backset 7 mm

0507063

50



ZM PA

7 mm

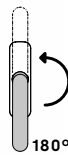

Mecanismo que a través de una manilla permite desplazar las fallebas y los puntos de cierre que abren la ventana.

- Mecanismo monodireccional especialmente diseñado para aperturas practicable y oscilobatientes.
- Incorpora un tope que limita la rotación de la manilla a 90° para ventanas de apertura practicable.
- Incorpora piezas telescópicas regulables para adaptarse a cualquier tipo de hoja de ventana.
- La fijación de la caja de transmisión al perfil se realiza mediante tornillos.

Mechanism that through a handle allows to move the transmission rods and the locking points that open the window.

- One-way mechanism specially designed for side-hung and tilt & turn window openings.
- The gearbox incorporates a stop that limits the rotation of the handle to 90° for side-hung window opening.
- It incorporates adjustable telescopic pieces to adapt to any type of window sash.
- The gearbox is fixed to the profile with screws.

REF. 0507063

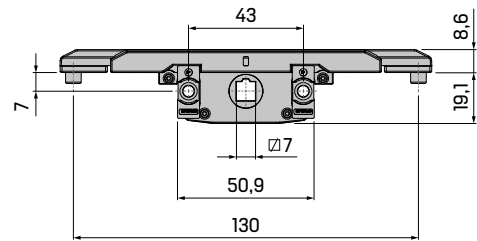

**MONODIRECCIONAL Aguja 7 mm**  
ONE-WAY Backset 7 mm

A770001

**Manillas minimalistas**  
Minimalist handles

25



ZM PA

INX POM

8 mm

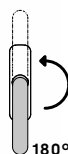

REF. A770001

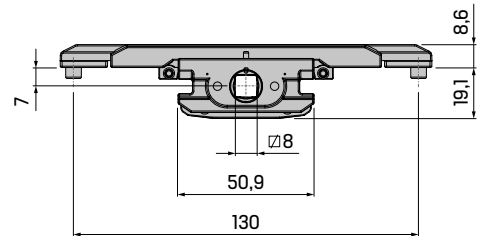

**MECANIZADOS PARA MANILLA OSCIOBATIENTE**  
TILT & TURN HANDLE MACHINING PROFILE

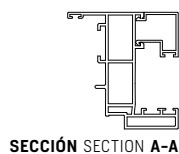
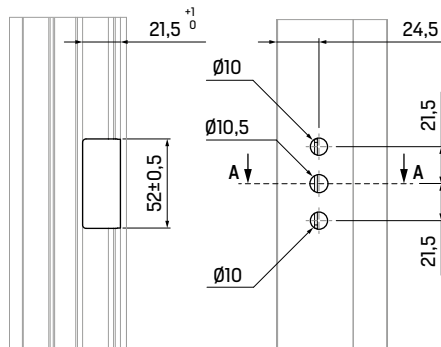

**MECANIZADOS PARA MANILLAS MINIMALISTAS**  
MINIMALIST HANDLES MACHINING PROFILE

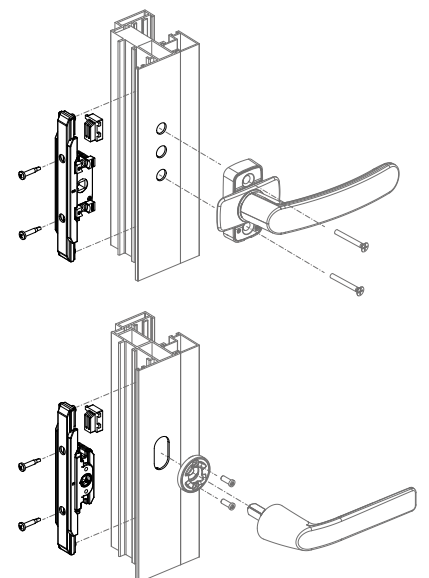
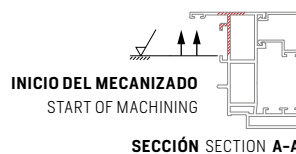
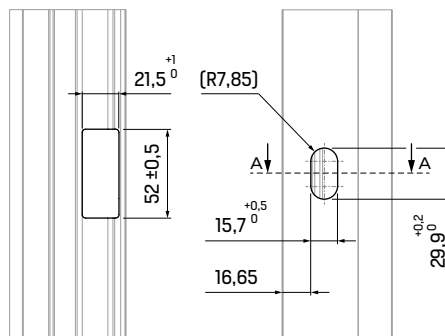

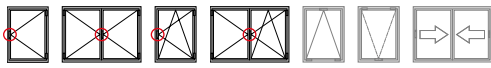

Mechanism that through a handle allows to move the transmission rods and the locking points that open the window.

Mecanismo que a través de una manilla permite desplazar las fallebas y los puntos de cierre que abren la ventana.

**Gearbox 0507177**

- Installation valid for outward or side-hung openings with door or balcony door profiles.

**Caja de transmisión 0507177**

- Instalación en aperturas exteriores o practicables con perfiles de puerta o puerta balconera.

**Gearbox 0507178**

- Installation valid for balcony door profiles with tilt & turn or side-hung opening with micro-ventilation.

**Caja de transmisión 0507178**

- Instalación en perfiles de puerta balconera con apertura oscilobatiente o practicable con microventilación.

**Gearbox 0507248**

- Installation valid for outward or side-hung openings with door or balcony door profiles.

**Caja de transmisión 0507248**

- Instalación en aperturas exteriores o practicables con perfiles de puerta o puerta balconera.

**REF. 0507177**

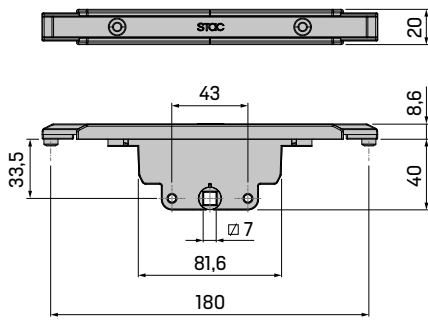

**REF. 0507178**

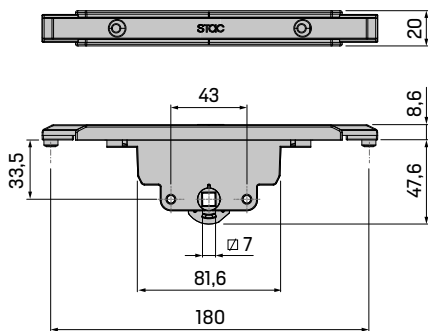

**REF. 0507248**

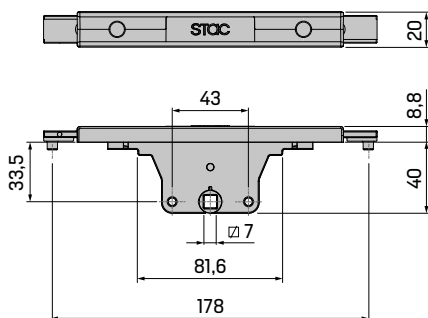

**■ MECANIZADOS PARA APERTURA EXTERIOR**  
OUTWARD OPENING MACHINING PROFILE

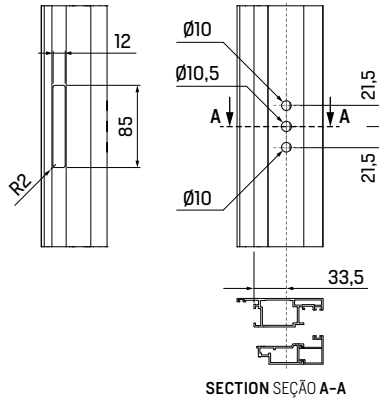

**■ MECANIZADOS PARA PUERTA BALCONERA**  
DOOR BALCONY MACHINING PROFILE

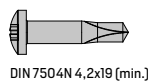
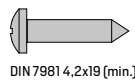
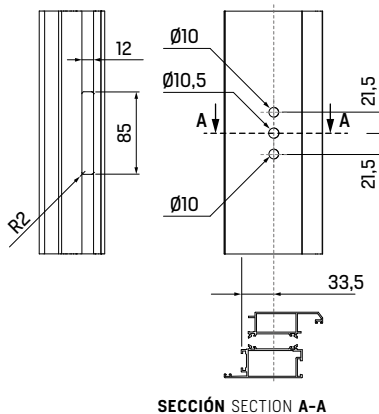

**MONODIRECCIONAL Aguja 33,5 mm**  
ONE-WAY Backset 33,5 mm



0507177

ZM

7 mm

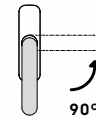

25



**MONODIRECCIONAL Aguja 33,5 mm**  
ONE-WAY Backset 33,5 mm



0507178

ZM

7 mm

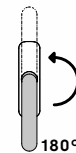

25



**BIDIRECCIONAL Aguja 33,5 mm**  
TWO-WAY Backset 33,5 mm



0507248

ZM

7 mm

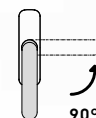

25





**APERTURA PRACTICABLE CON CIERRE AL INVERSOR**  
SIDE-HUNG OPENING WITH LOCKING TO THE INVERTER

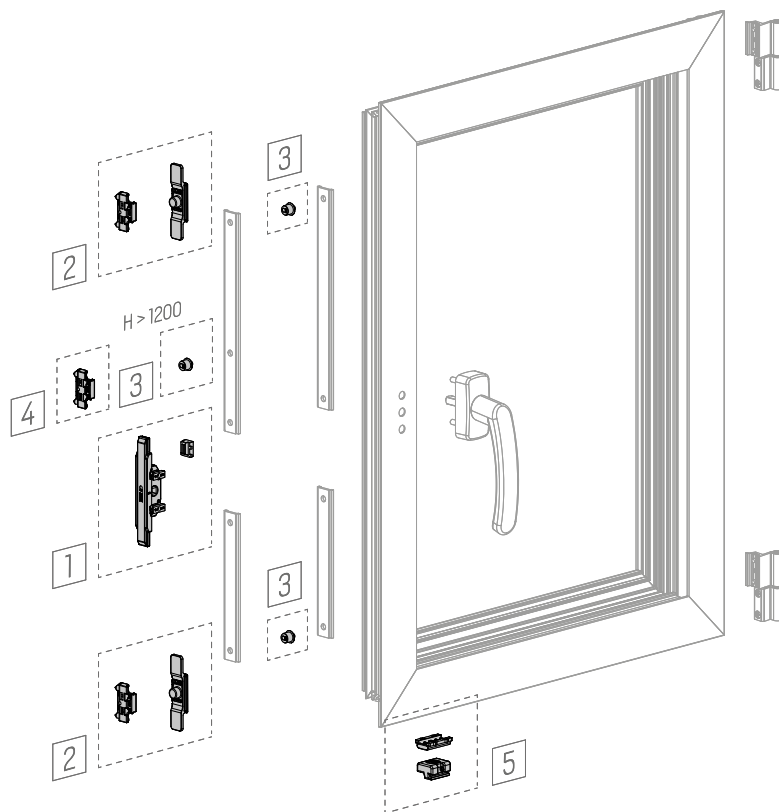

**CIERRE AL INVERSOR**  
LOCKING TO THE INVERTER



1	0507063	<b>CAJA DE TRANSMISIÓN</b> GEARBOX	50
2	113000IM	<b>KIT PUNTO DE CIERRE SUPLEMENTARIO</b> SUPPLEMENTARY LOCKING POINT KIT	50
3	0517002	<b>PUNTO DE CIERRE: REMACHE Ø6</b> LOCKING POINT: RIVET Ø6	50
4	110200	<b>PUNTO DE CIERRE REGULABLE</b> ADJUSTABLE LOCKING POINT	500
5	0710621	<b>KIT RESBALÓN DE POSICIONAMIENTO</b> POSITIONING LATCH KIT	100





**APERTURA PRACTICABLE CON CIERRE AL MARCO**  
SIDE-HUNG OPENING WITH LOCKING TO THE FRAME

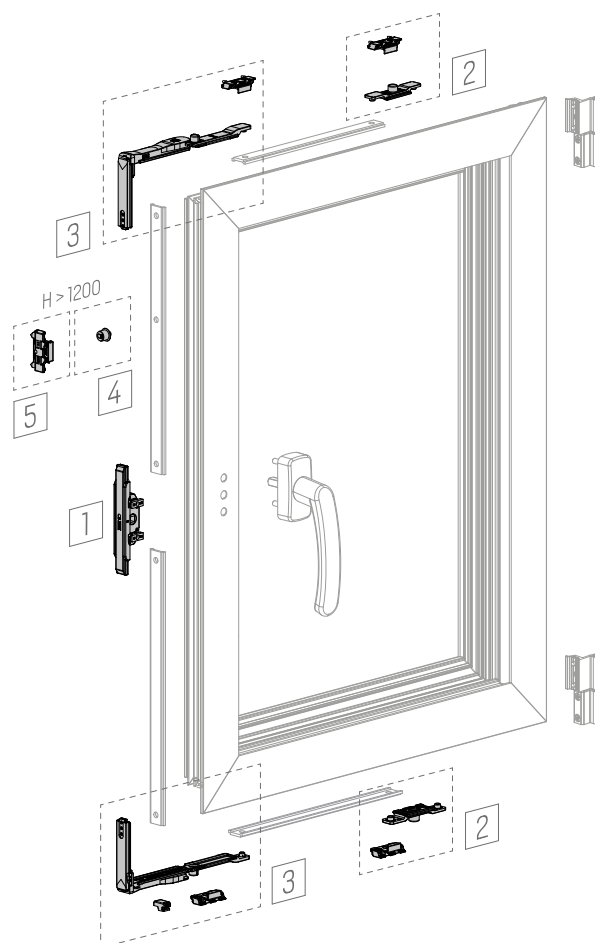
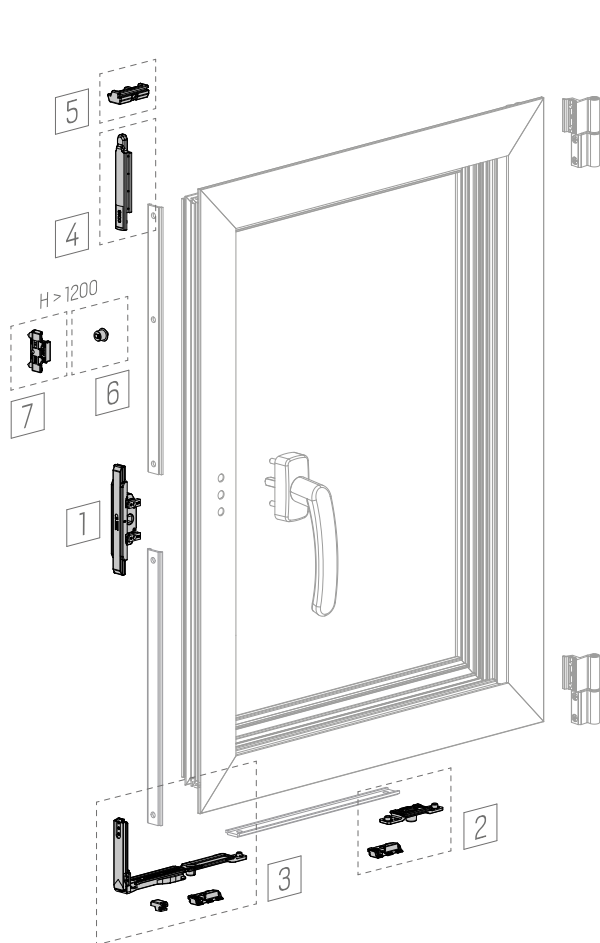

**CIERRE AL MARCO CON ÁNGULO DE REENVIO Y PUNTERO**  
LOCKING TO THE FRAME WITH CORNER DRIVE AND POINTER



1	0507063	<b>CAJA DE TRANSMISIÓN</b> GEARBOX	50
2	113000IM	<b>KIT PUNTO DE CIERRE SUPLEMENTARIO</b> SUPPLEMENTARY LOCKING POINT KIT	50
3	113420	<b>KIT ÁNGULO DE REENVIO HORIZONTAL</b> HORIZONTAL CORNER DRIVE KIT	20
4	07085	<b>PUNTERO Ø6 PARA AP. PRACTICABLE</b> SIDE-HUNG OPENING Ø6 POINTER	1000
5	0710621	<b>KIT RESBALÓN DE POSICIONAMIENTO</b> POSITIONING LATCH KIT	100
6	0507105	<b>CERRADERO</b> KEEPER	50
7	110200	<b>PUNTO DE CIERRE REGULABLE</b> ADJUSTABLE LOCKING POINT	500

**CIERRE AL MARCO CON DOBLE ÁNGULO DE REENVIO**  
LOCKING TO THE FRAME WITH DOUBLE CORNER DRIVE



1	0507063	<b>CAJA DE TRANSMISIÓN</b> GEARBOX	50
2	113000IM	<b>KIT PUNTO DE CIERRE SUPLEMENTARIO</b> SUPPLEMENTARY LOCKING POINT KIT	50
3	113420	<b>KIT ÁNGULO DE REENVIO HORIZONTAL</b> HORIZONTAL CORNER DRIVE KIT	20
4	0517002	<b>PUNTO DE CIERRE: REMACHE Ø6</b> LOCKING POINT: RIVET Ø6	50
5	110200	<b>PUNTO DE CIERRE REGULABLE</b> ADJUSTABLE LOCKING POINT	500

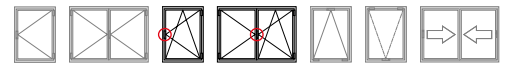

**APERTURAS OSCILOBATIENTES**  
 TILT & TURN OPENINGS

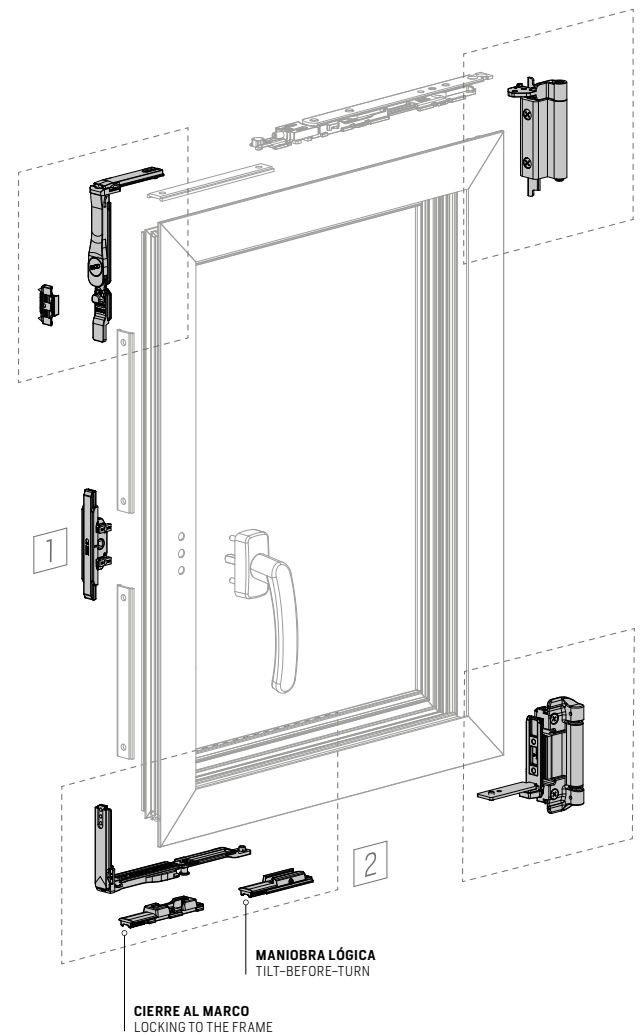
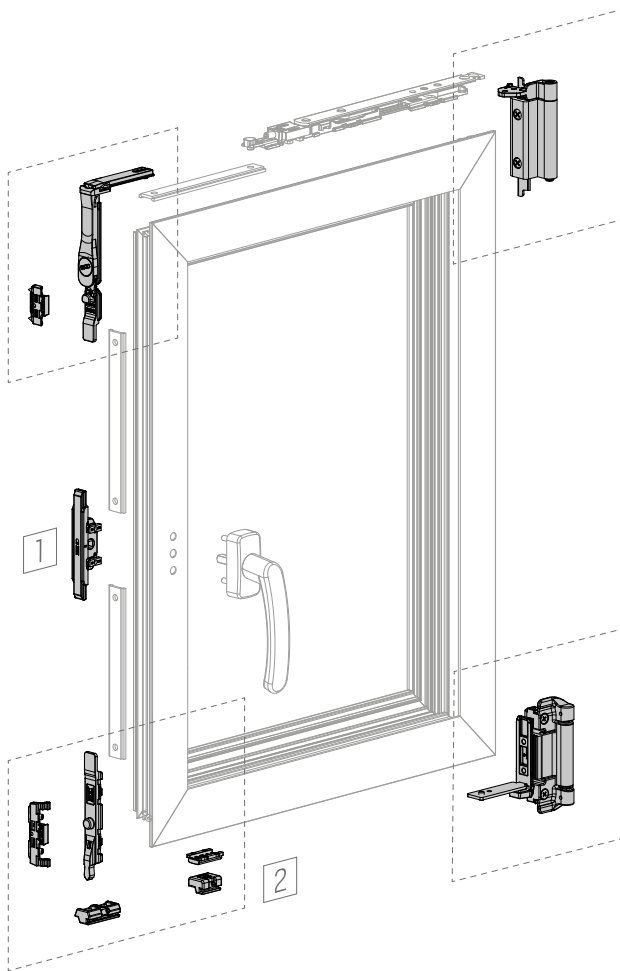

**CIERRE AL INVERSOR**  
 LOCKING TO THE INVERTER



1	0507063	<b>CAJA DE TRANSMISIÓN</b> GEARBOX	50
2	1133 **	<b>KIT OSCILOBATIENTE CON CIERRE AL INVERSOR</b> TILT & TURN KIT WITH LOCKING TO THE INVERTER	24

**CIERRE AL MARCO**  
 LOCKING TO THE FRAME



1	0507063	<b>CAJA DE TRANSMISIÓN</b> GEARBOX	50
2	1139 **	<b>KIT OSCILOBATIENTE CON CIERRE AL MARCO</b> TILT & TURN KIT WITH LOCKING TO THE FRAME	24
	1123 **	<b>KIT OSCILOBATIENTE CON MANIOBRA LÓGICA</b> TILT & TURN KIT WITH TILT-BEFORE-TURN	

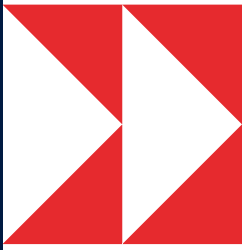

# 10

## HOJA PASIVA PASSIVE SASH

- 214 **Pasadores de palanca bidireccionales**  
Two-way shootbolt levers
- 216 **Pasadores de palanca**  
Shootbolt levers
- 218 **Pasadores de palanca extensibles**  
Extendable shootbolt levers
- 219 **Pasadores de falleba**  
Transmission rod levers
- 220 **Clip retenedor de hoja**  
Sash retainer clip
- 221 **Cierres perimetrales de hoja**  
Sash perimeter closures
- 222 **Pasadores para puerta DENEb**  
DENEb door flush bolts



## PASADORES DE PALANCA BIDIRECCIONALES AP. OSCILOBATIENTE

TWO-WAY SHOOTBOLT LEVERS TILT & TURN OPENING

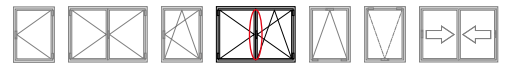

### KIT PASADOR BIDIRECCIONAL CIERRE AL INVERSOR

TWO-WAY SHOOTBOLT KIT LOCKING TO INVERTER

111601

20



ZM INX

PA PVC



Kits de cierre para hoja pasiva con Canal Europeo mediante pasadores de palanca bidireccionales.

- Los kits están compuestos por dos terminales conectados a una palanca mediante pletinas falleba.
- Los terminales de zamak se accionan (apertura / cierre) por la operación de una única palanca.
- Los terminales incorporan puntos de cierre con regulación de presión.
- Los punteros en acero inoxidable aportan mayor resistencia.

Locking kits for passive sash with Euro Groove by means of two-way shootbolt levers.

- The kits consist of two terminals connected to a lever by means of transmission rod plates.
- The terminals manufactured in zamak are operated (open / close) by the operation of a single lever.
- The terminals incorporate locking points with tightening adjustment.
- The stainless steel pointers provide greater resistance.

### KIT PASADOR BIDIRECCIONAL CIERRE AL MARCO

TWO-WAY SHOOTBOLT KIT LOCKING TO FRAME

111602

20



ZM INX

PA PVC



REGULACIÓN ± 1,5 mm  
± 1,5 mm ADJUSTMENT

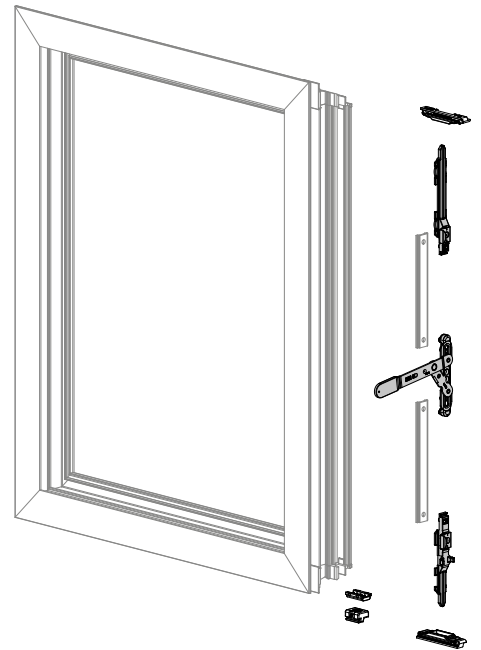
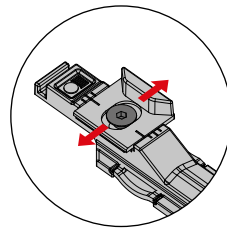

### KIT PASADOR BIDIRECCIONAL CON PUNTEROS INOX

TWO-WAY SHOOTBOLT KIT WITH INOX POINTERS

111621

20



ZM INX

PA PVC

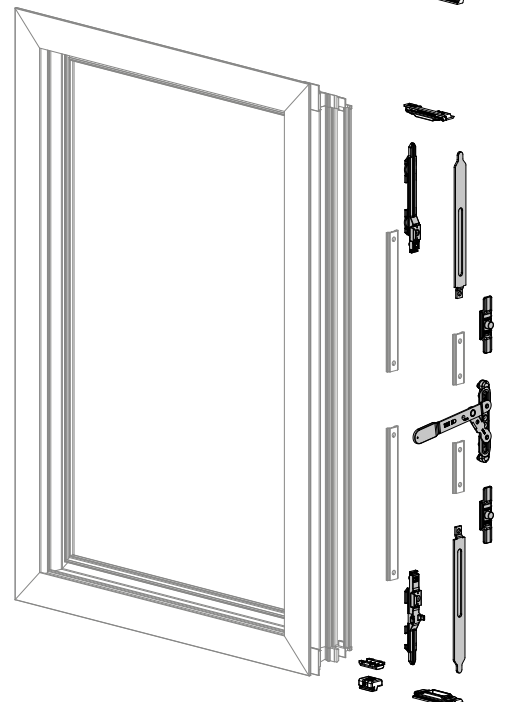

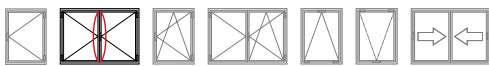

## PASADORES DE PALANCA BIDIRECCIONALES AP. PRACTICABLE

### TWO-WAY SHOOTBOLT LEVERS SIDE-HUNG OPENING

Locking kits for passive sash with Euro Groove by means of two-way shootbolt levers.

- The kits consist of two terminals connected to a lever by means of transmission rod plates.
- The terminals manufactured in plastic are operated (open / close) by the operation of a single lever.

Kits de cierre para hoja pasiva con Canal Europeo mediante pasadores de palanca bidireccionales.

- Los kits están compuestos por dos terminales conectados a una palanca mediante pletinas falleba.
- Los terminales de plástico se accionan (apertura / cierre) por la operación de una única palanca.

## KIT PASADOR DE PALANCA BIDIRECCIONAL

### TWO-WAY SHOOTBOLT LEVER KIT



071600



## KIT PASADOR BIDIRECCIONAL CON PUNTA METÁLICA

### TWO-WAY SHOOTBOLT KIT WITH METALLIC TIP



071601

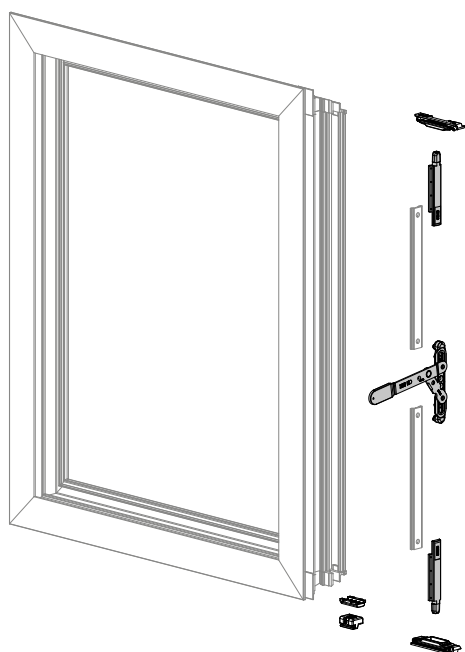
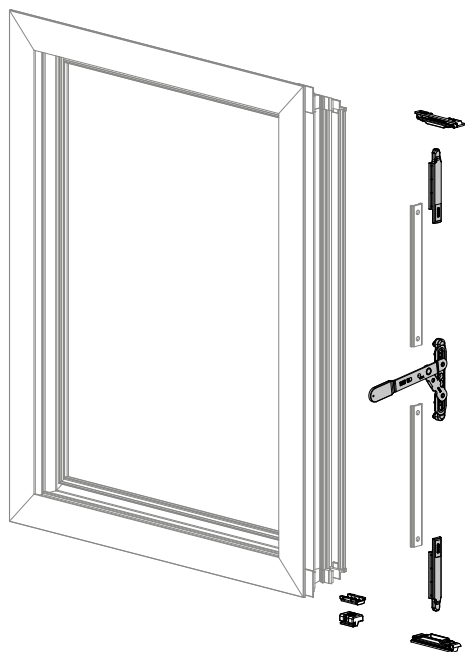

EJE SHAFT 10

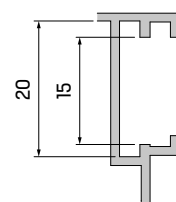

INVERSOR MARCO / HOJA  
FRAME INVERTER / SASH  
111601, 111602, 071600, 071601

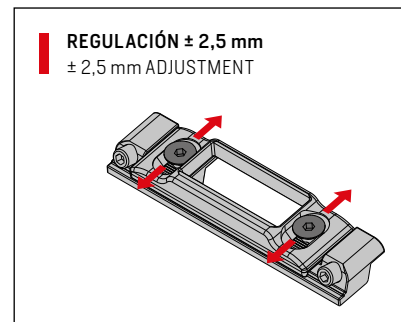

## PASADORES DE PALANCA APERTURA OSCILOBATIENTE

SHOOTBOLT LEVERS TILT & TURN OPENING

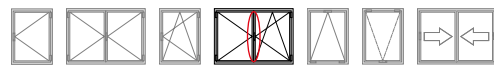

### KIT PASADOR DE PALANCA CIERRE AL INVERSOR

SHOOTBOLT LEVER KIT LOCKING TO INVERTER

A111600

H min = 665 mm



ZM INX

PA



20



Kits de cierre para hoja pasiva por medio de pasadores de palanca.

Locking kits for passive sash by means of shootbolt levers.

- Los pasadores son válidos para aperturas oscilobatientes y practicables.
- Los pasadores de palanca se suministran montados y se fijan de forma rápida superponiéndolos en el perfil.
- Los pasadores de palanca incorporan puntos de cierre regulables para antifalsa maniobra y para el terminal de hoja activa.
- Los cerraderos son regulables y poseen un ranurado antideslizamiento el cual permite realizar un ajuste progresivo.
- Pre-posicionado mediante lágrima de acero excéntrica con el objetivo de para facilitar la instalación.
- Las piezas de zamak han sido tratadas para garantizar resistencia a la corrosión de 240 horas en cámara de niebla salina de acuerdo con lo establecido en la norma UNE-EN 1670 (Grado 4).

- The shootbolt lever kits are valid for tilt & turn and side-hung openings.
- The shootbolt levers are supplied fully assembled and are quickly fixed by overlapping them in the profile.
- The shootbolt levers are equipped with adjustable locking points for anti-false operation and for the end of the active sash terminal.
- The keepers are adjustable and have an anti-slip groove that allows for progressive adjustment.
- Pre-positioned by means of an eccentric steel teardrop to facilitate correct installation.
- The zamak parts have been treated to guarantee 240 hours of corrosion resistance in a saline mist chamber in accordance with the UNE-EN 1670 standard (Grade 4).

### KIT PASADOR DE PALANCA CIERRE AL MARCO

SHOOTBOLT LEVER KIT LOCKING TO FRAME

A113800

H min = 665 mm



ZM INX

PA



20

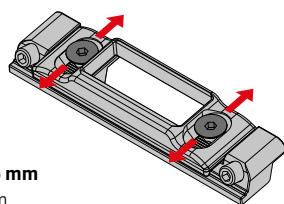

PERMITE REGULACIÓN DE  $\pm 2,5$  mm  
ALLOWS REGULATION OF  $\pm 2,5$  mm

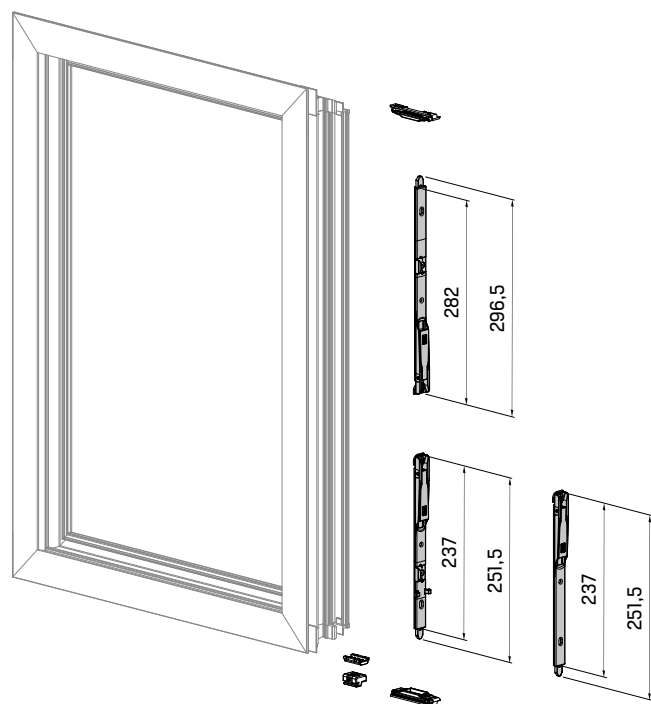

FIJACIÓN POR LÁGRIMA EXCÉNTRICA  
ECCENTRIC TEARDROP FIXING

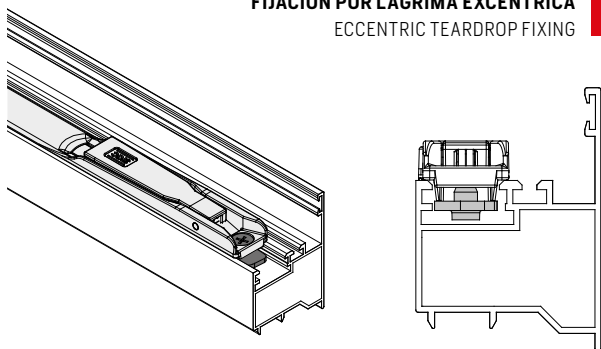

EJE SHAFT 10

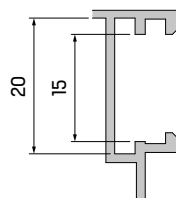

INVERSOR MARCO / HOJA  
FRAME INVERTER / SASH

EJE SHAFT 10

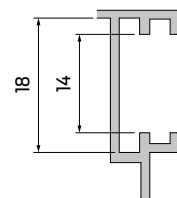

INVERSOR MARCO / MARCO  
FRAME INVERTER / FRAME

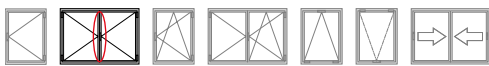

Locking kits for passive sash by means of shootbolt levers.

- The shootbolt lever kits are valid for side-hung openings.
- The shootbolt levers are supplied fully assembled and are quickly fixed by overlapping them in the profile.
- The shootbolt levers are equipped with adjustable locking points for anti-false operation and for the end of the active sash terminal.
- The keepers are adjustable and have an anti-slip groove that allows for progressive adjustment.
- Pre-positioned by means of an eccentric steel teardrop to facilitate correct installation.
- The zamak parts have been treated to guarantee 240 hours of corrosion resistance in a saline mist chamber in accordance with the UNE-EN 1670 standard (Grade 4).

Kits de cierre para hoja pasiva por medio de pasadores de palanca.

- Los pasadores son válidos para aperturas practicables.
- Los pasadores de palanca se suministran montados y se fijan de forma rápida superponiéndolos en el perfil.
- Los pasadores de palanca incorporan puntos de cierre regulables para antifalsa maniobra y para el terminal de hoja activa.
- Los cerraderos son regulables y poseen un ranurado antideslizamiento el cual permite realizar un ajuste progresivo.
- Pre-posicionado mediante lágrima de acero excéntrica con el objetivo de para facilitar la instalación.
- Las piezas de zamak han sido tratadas para garantizar resistencia a la corrosión de 240 horas en cámara de niebla salina de acuerdo con lo establecido en la norma UNE-EN 1670 (Grado 4).

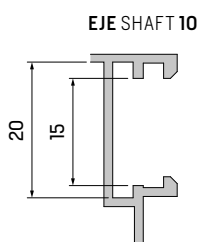
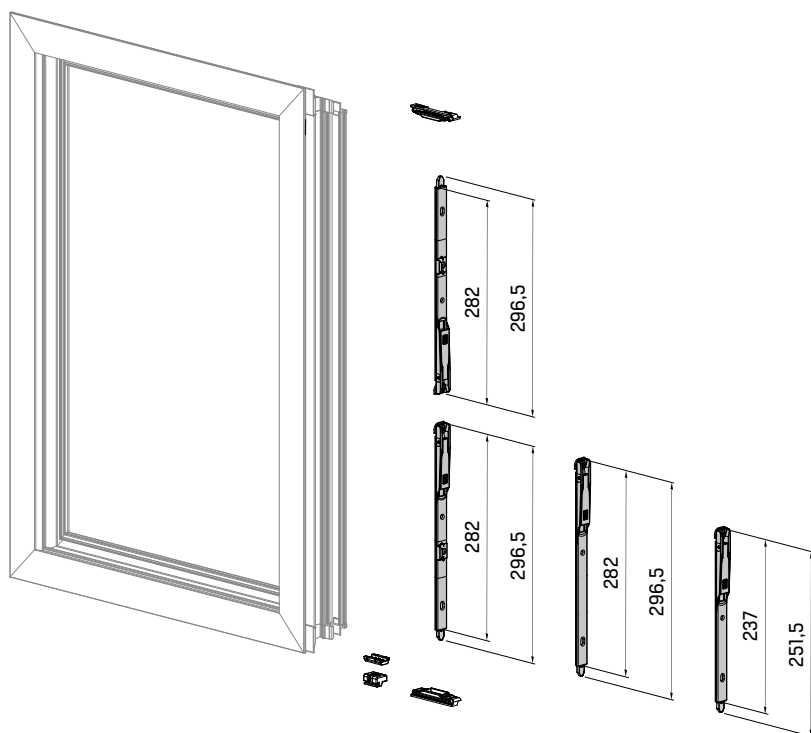

**INVERSOR MARCO / HOJA**  
FRAME INVERTER / SASH

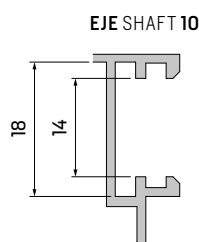

**INVERSOR MARCO / MARCO**  
FRAME INVERTER / FRAME

**KIT PASADORES LARGOS CON PUNTOS DE CIERRE**  
LONG SHOOTBOLT LEVER KIT WITH LOCKING POINTS



A113700



**KIT PASADOR LARGO CON PUNTO DE CIERRE**  
LONG SHOOTBOLT LEVER KIT WITH LOCKIN POINT



A112720



**KIT PASADOR DE PALANCA CORTO**  
SHORT SHOOTBOLT LEVER KIT



A112610



**KIT PASADOR DE PALANCA LARGO**  
LONG SHOOTBOLT LEVER KIT



A112710



## PASADORES DE PALANCA EXTENSIBLES APERTURA OSCILOBATIENTE

EXTENDABLE SHOOTBOLT LEVERS TILT & TURN OPENING

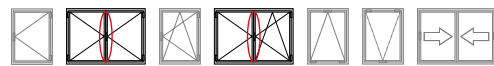

### KIT PASADORES EXTENSIBLES CIERRE AL INVERSOR EXTEND. SHOOTBOLT LEVER KIT LOCKING TO INVERTER

111610

H min = 750 mm



ZM INX

PA



20



Kit de cierre para hoja pasiva mediante pasadores de palanca extensibles.

Locking kit for the passive sash using extendable shootbolts levers.

- La posición de los pasadores es totalmente regulable en altura y en apriete.
- Los pasadores son ideales para perfiles de puertas balconera.
- Los pasadores son extensibles por medio de pletinas falleba.
- Los pasadores incorporan clip antiholguras y están ajustados a todos los inversores del mercado.
- Incorporan un sistema de seguridad con bloqueo de palanca incorporado.
- Los punteros en acero inoxidable aportan mayor resistencia y son compatibles con los kits de cierre al marco y cierre al inversor de hoja activa.

- The position of the levers is fully adjustable in height and tightening.
- The shootbolts levers are ideal for balcony door profiles.
- The shootbolts levers are extendable by means of rod plates.
- The shootbolts levers are fitted with an anti-looseness clip and are suitable for all reversing devices on the market.
- The shootbolts levers have a safety system with a built-in lever lock.
- The stainless steel pointers provide greater resistance and are compatible with the locking the frame and locking to inverter kits for the active sash.

### KIT PASADORES EXTENSIBLES CIERRE AL MARCO EXTEND. SHOOTBOLT LEVER KIT LOCKING TO FRAME

111611

H min = 770 mm



ZM INX

PA



20



### KIT PASADORES EXTENSIBLES CON PUNTEROS INOX EXTEND. SHOOTBOLT LEVER KIT WITH INOX POINTERS

111620



ZM INX

PA

20



EXTENSIBLES POR MEDIO DE FALLEBA  
EXTENDABLE BY MEANS OF A ROD

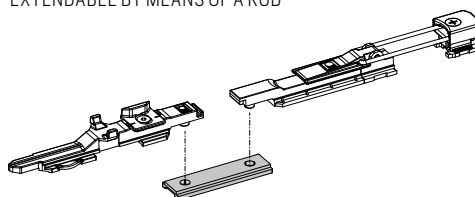

EJE SHAFT 10

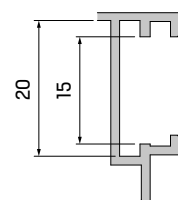

INVERSOR MARCO / HOJA  
FRAME INVERTER / SASH



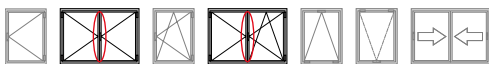

Locking kit for the passive sash using transmission rod levers.

- The transmission rod levers are made up of a die-cut aluminium plate and a button injected with polyamide and fibreglass.
- The keepers have an anti-slip groove that allows progressive adjustment.

Kit de cierre para hoja pasiva mediante pasadores de falleba.

- Los pasadores de falleba están constituidos por una pletina de aluminio troquelado y un pulsador inyectado en poliamida con fibra de vidrio.
- Los cerraderos poseen un ranurado antideslizamiento que permite realizar una regulación progresiva.

**KIT PASADORES DE FALLEBA 15 / 20**  
15 / 20 TRANSMISSION ROD LEVER KIT



H min = 620 mm

112000



**KIT PASADORES DE FALLEBA 14 / 18**  
14 / 18 TRANSMISSION ROD LEVER KIT



H min = 620 mm

112001

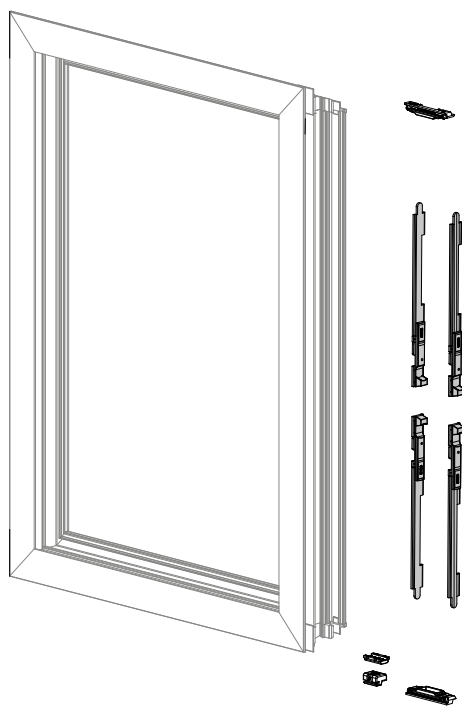

EJE SHAFT 10

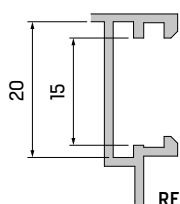

REF. 112000

**INVERSOR MARCO / HOJA**  
FRAME INVERTER / SASH

EJE SHAFT 10

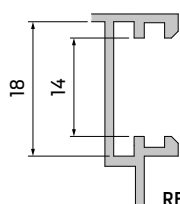

REF. 112001

**INVERSOR MARCO / MARCO**  
FRAME INVERTER / FRAME

## CLIP RETENEDOR DE HOJA SASH RETAINER CLIP

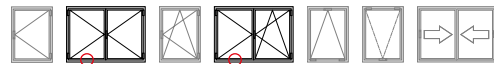

### KIT CLIP RETENEDOR DE HOJA SASH RETAINER CLIP KIT

0507047



ZM INX

50



Mecanismo que permite mantener bloqueada la hoja pasiva.

- Permite mantener bloqueada la hoja secundaria cuando está cerrada.
- El clip de retención se desactiva tirando de la hoja directamente.
- Las dos partes que componen el kit son desmontables y ambas admiten regulación sobre el canal lateral.

Mechanism that allows the passive sash to be kept locked.

- The mechanism allows the secondary sash to be kept locked when closed.
- The retaining clip is deactivated by pulling the sash directly.
- The two parts that make up the kit are removable and both can be adjusted on the side groove.

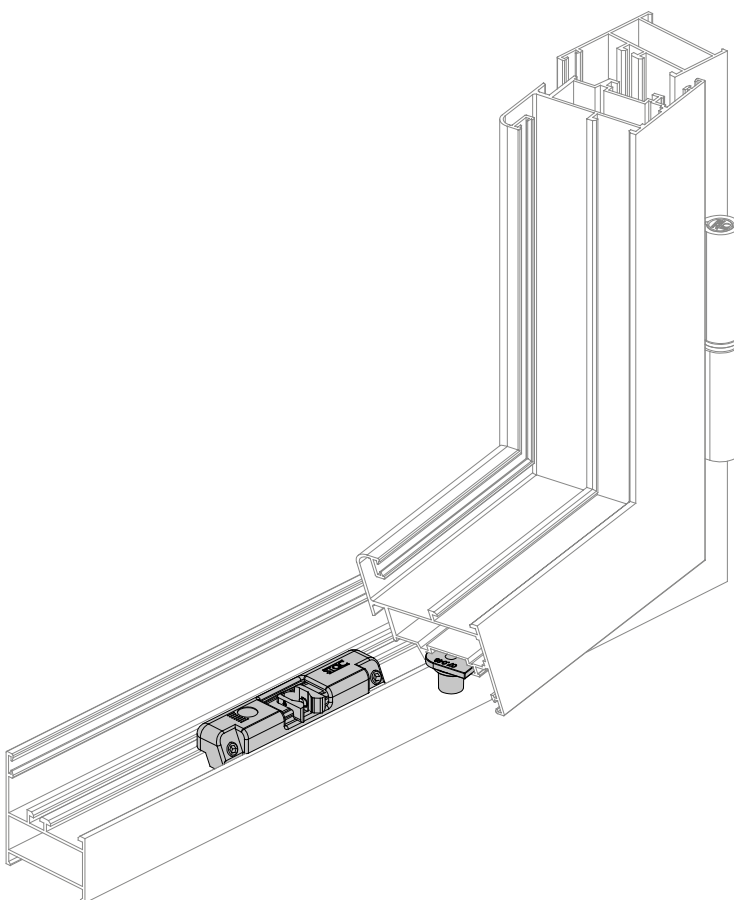

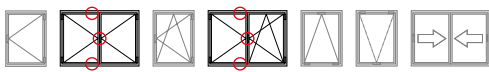

## CIERRES PERIMETRALES DE HOJA SASH PERIMETER CLOSURES

Closing kits for passive sash by means of a double corner drive that allows the perimeter closing of the secondary sash.

- The kits are operated by means of a two-way shootbolt lever.
- Easy adaptation to the different profile series on the market.
- The kits are available in EVO-SOFT and EVO-SECURITY versions.

Check availability by series.

Kits de cierre para hoja pasiva mediante doble ángulo de reenvío que posibilita el cierre perimetral de la hoja secundaria.

- Los kits se accionan mediante pasador de palanca bidireccional.
- Fácil adaptación a las diferentes series de perfil del mercado.
- Los kits están disponibles en versiones EVO-SOFT y EVO-SECURITY.

Consultar disponibilidad por serie.

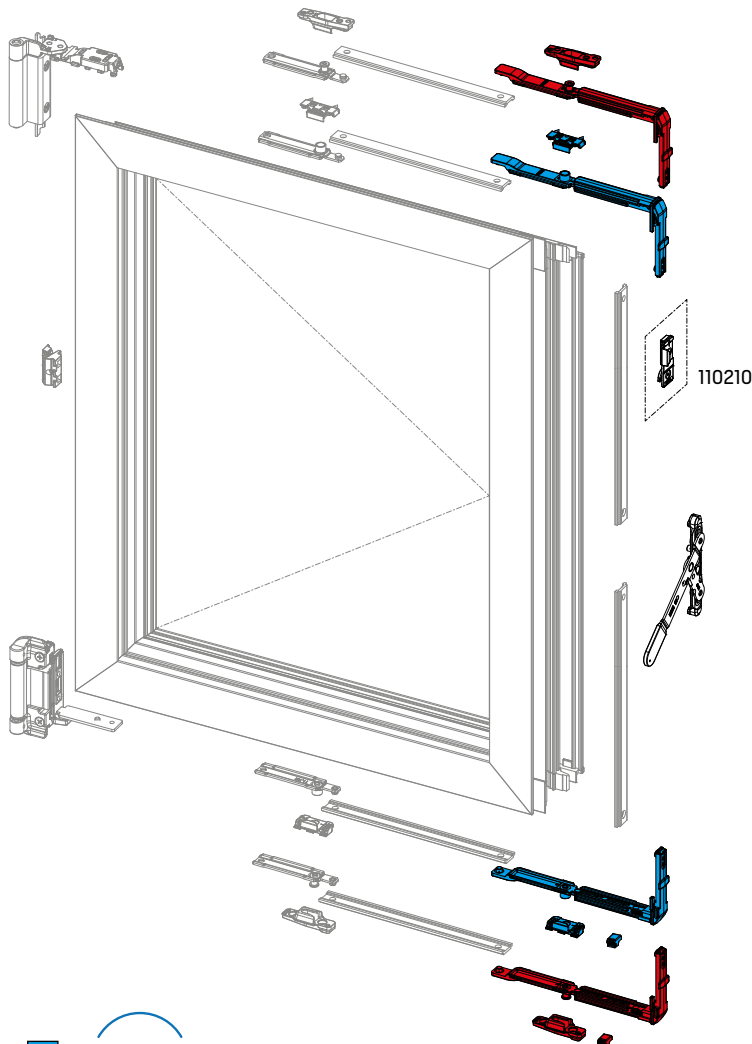

### KIT CIERRE PERIMETRAL EVO-SOFT EVO-SOFT SASH PERIMETER CLOSURE KIT



ZM INX

111604C



### KIT CIERRE PERIMETRAL EVO-SECURITY EVO-SECURITY SASH PERIMETER CLOSURE KIT



ZM INX

111604S



### PUNTO DE CIERRE PARA EL INVERSOR LOCKING POINT FOR THE INVERTER



ZM INX

110210



# DENEB

PASADORES FLUSH BOLTS



## » Adaptabilidad

Los pasadores de puerta DENEb están dimensionados de forma que se adapten a todos los canales de puerta estándar del mercado. Su geometría permite también que se puedan instalar en ventanas de Canal Europeo. Los pasadores DENEb están disponibles en tres longitudes diferentes: 140, 220 y 450 mm.

## » Resistencia

Los pasadores de puerta DENEb están fabricados en aluminio y zamak lacados, la palanca en zamak níquelado y los componentes principales que soportan los esfuerzos y desgastes están fabricados en acero inoxidable. Esto los dota de una gran resistencia a la corrosión.

## » Facilidad de accionamiento

El mecanismo de los pasadores de puerta DENEb acompaña el movimiento con dos resortes que derivan en una gran suavidad a la hora de accionar la palanca.

## » Estética estilizada

En la mayoría de los pasadores de puerta la estética está descuidada, quedando relegada a un segundo plano. Desde STAC hemos potenciado esta faceta dándole una estética estilizada y uniforme con acabados de calidad.



## » Adaptability

The DENEb flush bolts were designed to be compatible with all standard door groove profiles existing on the market. The geometry of the flush bolt allows its fitting on Euro Groove windows as well. To cover the entire range of door specifications the Deneb flush bolts come in three different lengths: 140, 220 and 450 mm.

## » Resistance

DENEb flush bolts are made of lacquered aluminium and zamak, the lever is made of nickel-plated zamak and the main components that support the stresses and wear are made of stainless steel. This gives them a great resistance to corrosion.

## » Easy operation

The mechanism of the DENEb flush bolts accompanies the movement with two springs that derive in a great smoothness at the time of operating the lever.

## » Stylish design

Aesthetical aspects are a secondary concern in most flush bolts. However, at STAC we deduced to reinforce this aspect, providing the DENEb flush bolts with a uniform, stylish design and a high-quality finish.

L			
140 mm	05240101	05240102	05240103
220 mm	05240201	05240202	05240203
450 mm	05240301	05240302	05240303
140 mm	05240401	05240402	05240403



The DENEb flush bolts are designed to fit all standard door groove profiles on the market.

- The DENEb flush bolts are manufactured in aluminium and zamak, the lever in nickel-plated zamak, the lacquered housings and the main components in stainless steel.

**140 mm flush bolt**

- DENEb door flush bolt of reduced dimensions specially designed for use in doors with multipoint locks.
- The flush bolt is available with a reinforcement plate that provides greater durability (ref. 052404).

**220 / 450 mm flush bolts**

- The flush bolts allow the user to get close to the lever in order to facilitate its operation.

Pasadores de puerta DENEb diseñados para adaptarse a todos los canales de puerta estándar del mercado.

- Los pasadores DENEb están fabricados en aluminio y zamak, la palanca en zamak niquelado, las carcasas lacadas y los componentes principales en acero inoxidable.

**Pasador de 140 mm**

- Pasador de dimensiones reducidas especialmente diseñado para su uso en puertas con cerraduras multipunto.
- El pasador está disponible con una placa de refuerzo que otorga mayor durabilidad (ref. 052404).

**Pasadores de 220 / 450 mm**

- Permiten al usuario acercarse a la palanca con el objetivo de facilitar su accionamiento.

**PASADORES DENEb**  
DENEb FLUSH BOLTS

AL ZM  
INX  
PH2

0524	01	**
	02	
	03	
	04	



**PUNTO DE CIERRE SUPERIOR**  
UPPER LOCKING POINT

ZM

0524020

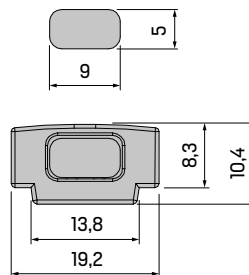
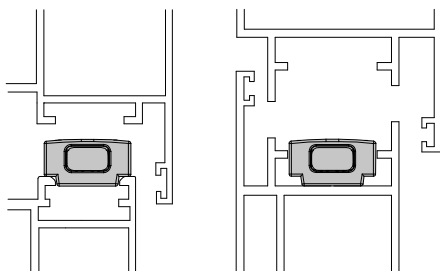
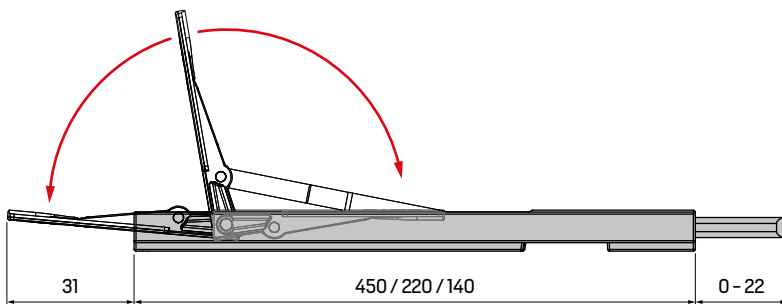

**GUARDAPOLVOS**  
DUST COVER

05241001

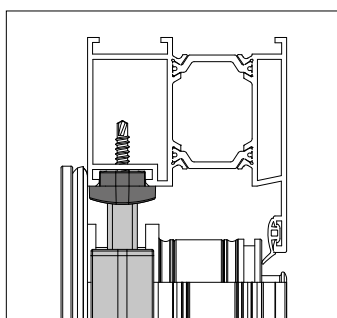
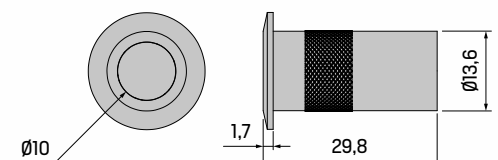

**PUNTO DE CIERRE SUPERIOR**  
UPPER LOCKING POINT

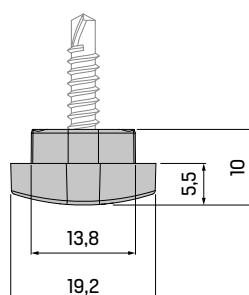



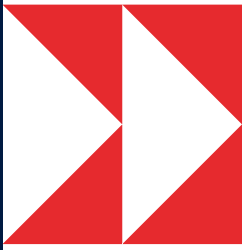

# 11

## APERTURA PROYECTANTE Y ABATIBLE TOP-HUNG & BOTTOM-HUNG OPENING

- 226 **Manilla PLEXUS**  
PLEXUS handle
- 228 **Cierres de presión**  
Pressure fasteners
- 231 **Manillas de fachada**  
Facade handles
- 232 **Cierre golpete**  
Catch
- 233 **Compases limitadores**  
Limiting friction stays
- 238 **Compases proyectantes**  
Top-hung friction stays
- 241 **Accesorios para apertura proyectante**  
Top-hung opening accessories
- 244 **Configuraciones para apertura proyectante**  
Top-hung opening configurations



# PLEXUS

Manilla proyectante Top-hung handle

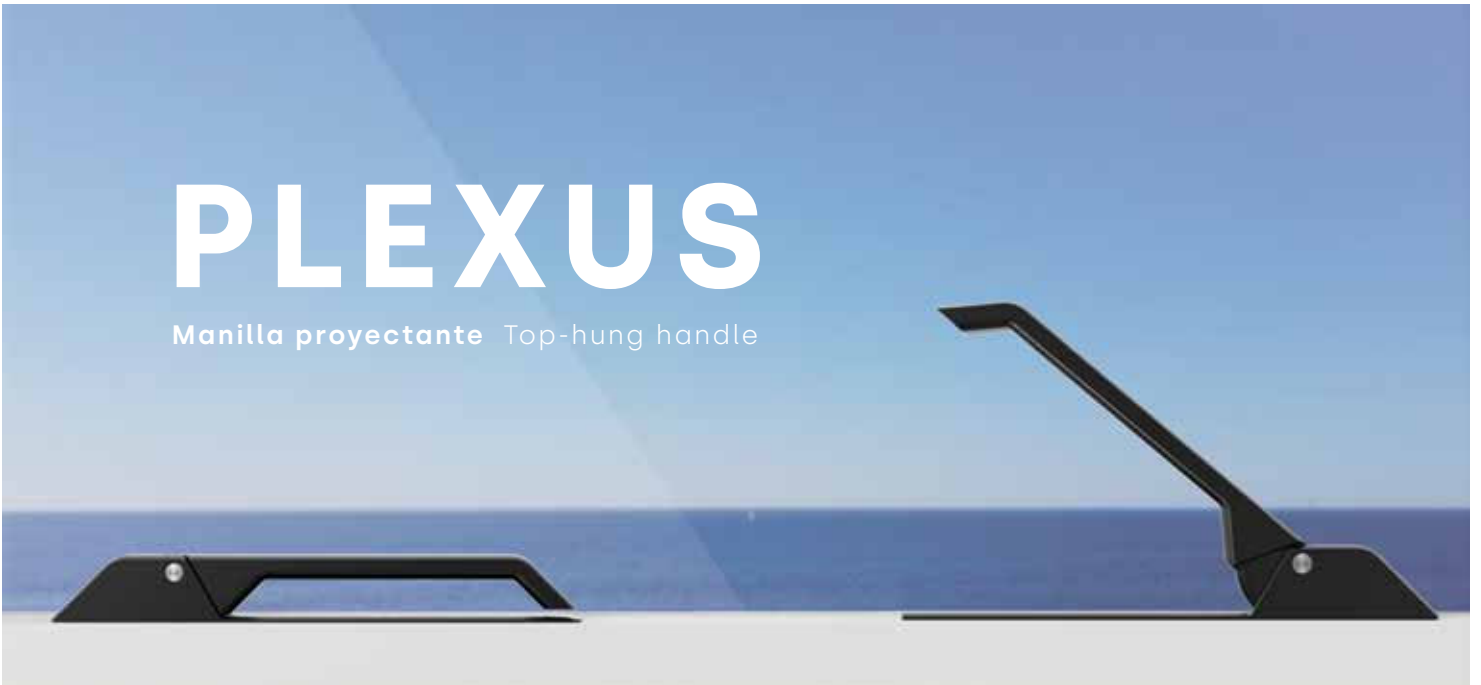

**Ventanas proyectantes**  
Top-hung windows



**Perfiles de Canal Europeo**  
Euro Groove profiles



**Personalización**  
Customization



**Instalación simple y rápida**  
Simple & quick installation

Los sistemas de apertura proyectantes son la solución perfecta para permitir la ventilación de fachadas acristaladas tipo muro cortina, ya que se integran perfectamente en los sistemas, aportando discreción y diseño a los mismos. La discreción a menudo se ve empañada por los sistemas de accionamiento ya que sobresalen mucho por encima de los perfiles y marcan perfectamente qué acristalamientos se pueden abrir y cuáles no.

La línea de diseño actual adoptada por STAC considera como uno de sus principales objetivos la simplificación del impacto visual de sus herrajes sin perder un ápice su funcionalidad. La manilla PLEXUS está adaptada a los sistemas más innovadores de apertura proyectante de Canal Europeo, con capacidad de instalarse en perfiles con un mínimo de 13 mm de medida hasta el canal, y que se integra a la perfección con los herrajes de STAC de Canal Europeo para aperturas proyectantes.

## » La solución perfecta para sistemas proyectantes

- Manilla de diseño innovador y simétrico de accionamiento intuitivo con una integración perfecta con la carpintería.
- Permite el montaje en perfiles de 13 mm como mínimo, adaptándose así a diferentes anchos del mismo de una forma simple.
- La manilla ha sido concebida para perfiles perimetrales de Canal Europeo y diseñada de tal forma que no tiene mano.

## » Personalización

Cada vez son más los proyectos que buscan su singularidad a través del color y en donde los accesorios se lacan en los mismos colores que la carpintería. Es por ello que la manilla PLEXUS está disponible en una amplia gama de acabados lacados basados en la carta de colores RAL.

Top-hung opening windows are the perfect solution for ventilating curtain wall type glass façades as they can be perfectly integrated into the façade, providing a discreet overall design. This discretion is often marred by the operating systems which can jut out beyond the profiles, making it obvious which glass panels open and which don't.

STAC's current design approach takes the reduction of visual impact of all hardware into account, without the slightest reduction in their functionality. The handle PLEXUS is adapted for use with the most innovative top-hung opening systems which use the Eurogroove profile. It can be installed on profiles with a minimum of 13 mm from the edge to the groove and, of course, it is fully integrated with all Euro Groove hardware for top-hung opening systems.

## » The perfect solution for top-hung windows

- Innovative and symmetrical handle design with intuitive operation and fully integration with the aluminium carpentry.
- It can be installed on profiles of minimum 13 mm, thus adapting to different widths in a simple way.
- The handle has been conceived for Euro Groove perimeter profiles and designed in such a way that it has no opening hand.

## » Customization

There are more and more projects that seek their uniqueness through colour and where the accessories are lacquered in the same colours as the carpentry. That is why the PLEXUS handle is available in a wide range of lacquered finishes based on the RAL colour chart.



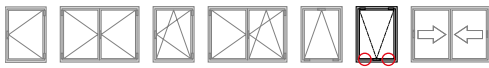

## MANILLA PARA APERTURA PROYECTANTE TOP-HUNG OPENING HANDLE

Handle specifically designed for top-hung window openings.

- Installation on profiles with a maximum of 19 mm in length up to the groove.
- The top-hung handle has been developed for Euro Groove perimeter window profiles and designed in such a way that it has no opening hand.
- The handle adapts to different groove widths in a simple way and allows single or double handle configurations.
- It features a simple installation system and profile machining.

Manilla específicamente diseñada para aperturas de ventana proyectantes.

- Instalación en perfiles con un máximo de 19 mm de medida hasta el canal.
- La manilla proyectante ha sido desarrollada para perfiles de ventana perimetrales de Canal Europeo y diseñada de tal forma que no tiene mano de apertura.
- Se adapta diferentes anchos de canal de forma simple y permite configuraciones de manilla simple o doble manilla.
- Presenta un sistema de montaje y mecanizados de perfil sencillos.

## MANILLA PROYECTANTE PLEXUS PLEXUS TOP-HUNG HANDLE

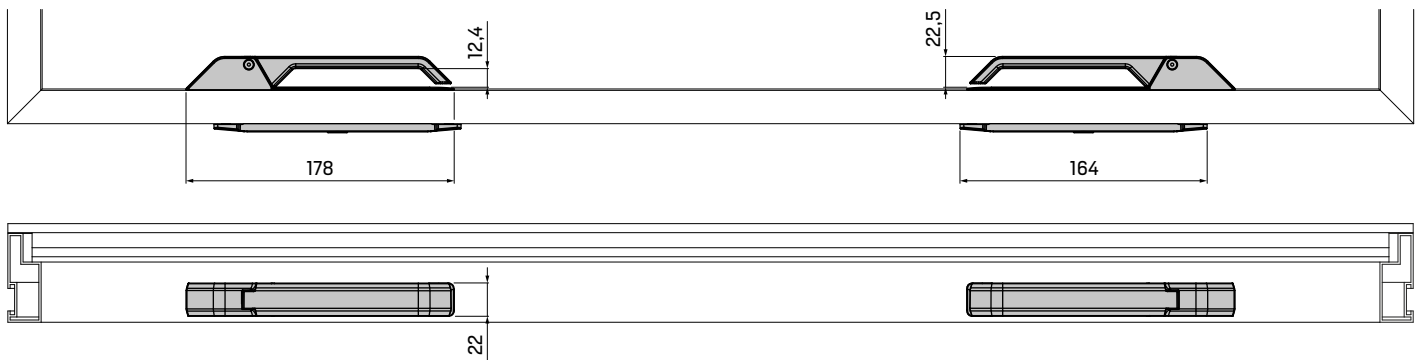
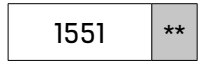

### ■ PROFUNDIDAD MÍNIMA DE PERFIL MINIMUM PROFILE DEPTH

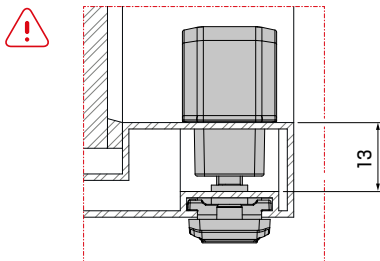

### ■ CONFIGURACIÓN DE MANILLA SIMPLE SINGLE HANDLE CONFIGURATION

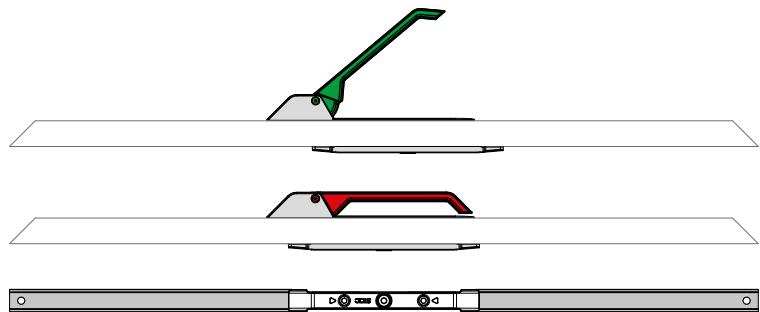

### ■ CONFIGURACIÓN DE DOBLE MANILLA DOUBLE HANDLE CONFIGURATION

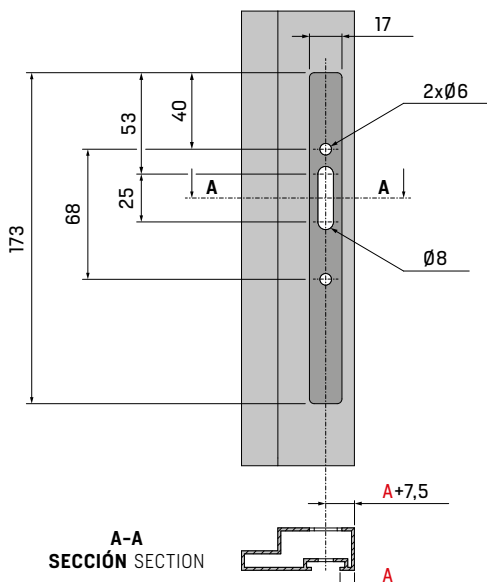
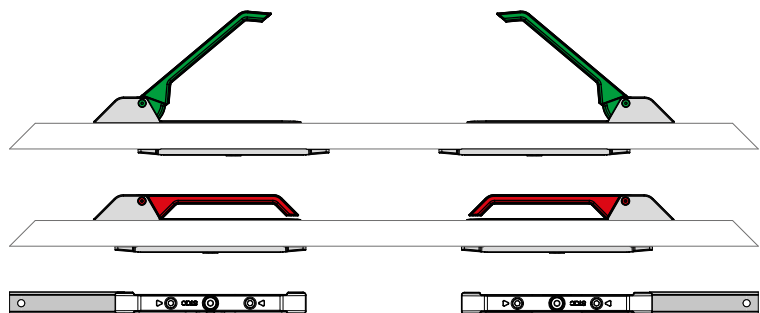

# CIERRE DE PRESIÓN SIRIUS

## SIRIUS PRESSURE FASTENER

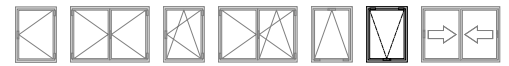

### CIERRE DE PRESIÓN SIRIUS

#### SIRIUS PRESSURE FASTENER

150	8	**
	9	

**Derecha** Right  
**Izquierda** Left



Cierres de presión diseñados para aperturas interiores y exteriores.

- La línea de diseño de la maneta favorece la integración con el resto de productos de las familias SIRIUS.
- Incluyen calzos para adaptarse a diferentes serie de perfiles y proporcionar mayor presión al cierre.
- Mediante un sistema de muelles, la tapas cubretornillos ocultan todo el mecanismo de fijación, aumentando la estética y contribuyendo a una instalación práctica y rápida.
- Los cierres incluyen embellecedores que permiten ocultar los tornillos del contracierre.
- Los cierres han sido testados de acuerdo con lo establecido en la norma UNE-EN 13126-2 a 10.000 ciclos obteniendo un resultado satisfactorio.

Window pressure fasteners designed for inward and outward openings.

- The design line of the handle favours integration with the other products of the SIRIUS families.
- They include shims to adapt to different series of profiles and to provide greater pressure when closing.
- By means of a spring system, the screw cover hides the whole fixing mechanism, increasing the aesthetics and contributing to a practical and fast installation.
- The closures include covers that allow the screws of the counter-closure to be hidden.
- The locks have been tested in accordance with the UNE-EN 13126-2 standard at 10,000 cycles, obtaining satisfactory results.

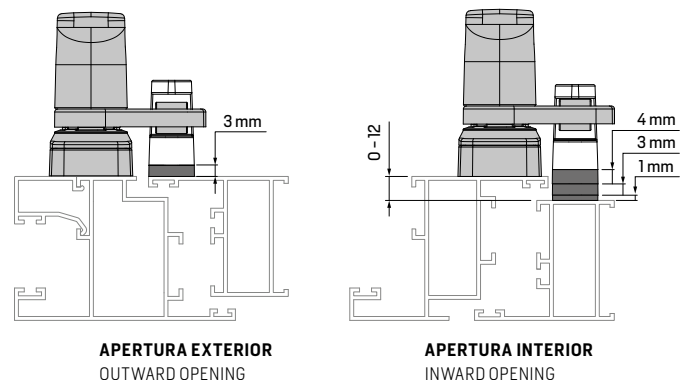
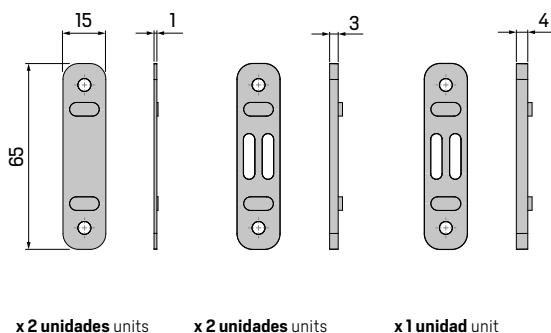
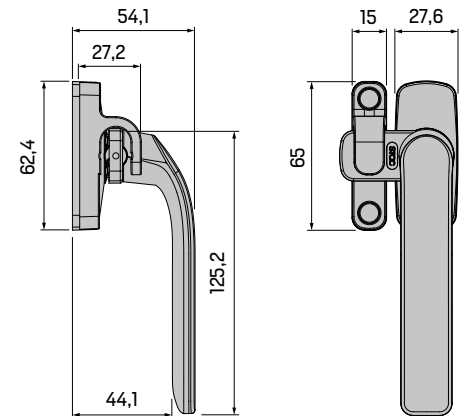
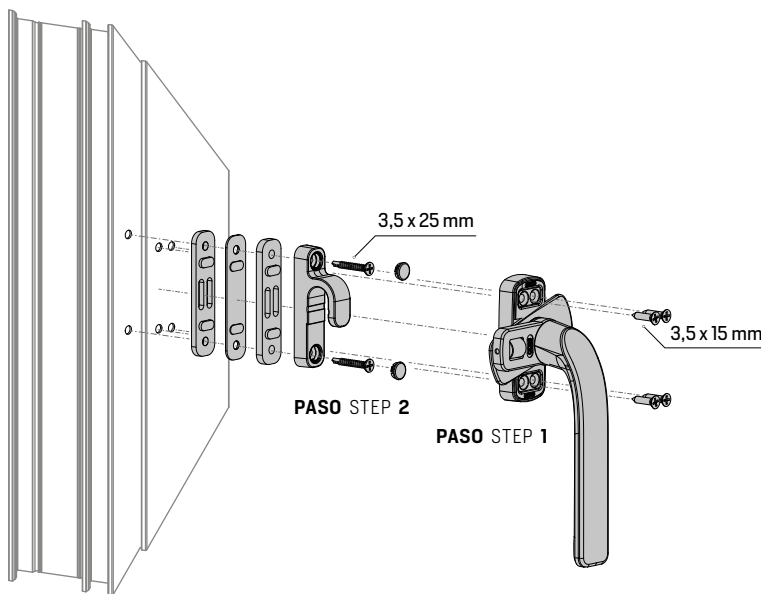

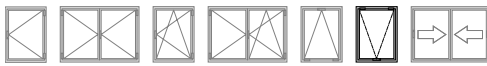

# CIERRE DE PRESIÓN LINCE

## LINCE PRESSURE FASTENER

Window pressure fasteners designed for inward and outward openings.

- The pressure fasteners include 1, 3 and 4 mm shims that allow the height to be increased to 12 mm to adapt to different series of existing profiles and provide greater pressure to the closure.
- By means of a spring system, the screw cover hides the whole fixing mechanism, increasing the aesthetics and contributing to a practical and fast installation.
- The closures include covers that allow the screws of the counter-closure to be hidden.
- The locks have been tested in accordance with the UNE-EN 13126-2 standard at 10,000 cycles, obtaining satisfactory results.

Cierres de presión diseñados para aperturas interiores y exteriores.

- Los cierres incluyen calzos de 1, 3 y 4 mm que permiten aumentar la altura hasta 12 mm para adaptarse a diferentes serie de perfiles existentes y proporcionar mayor presión al cierre.
- Mediante un sistema de muelles, la tapas cubretornillos ocultan todo el mecanismo de fijación, aumentando la estética y contribuyendo a una instalación práctica y rápida.
- Los cierres incluyen embellecedores que permiten ocultar los tornillos del contracierre.
- Los cierres han sido testados de acuerdo con lo establecido en la norma UNE-EN 13126-2 a 10.000 ciclos obteniendo un resultado satisfactorio.

# CIERRE DE PRESIÓN LINCE

## LINCE PRESSURE FASTENER



Derecha Right  
Izquierda Left

A150	6	**
	7	

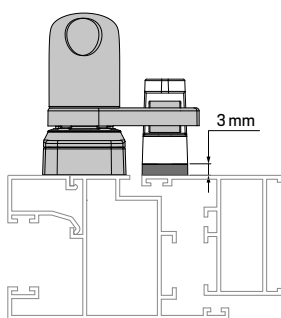
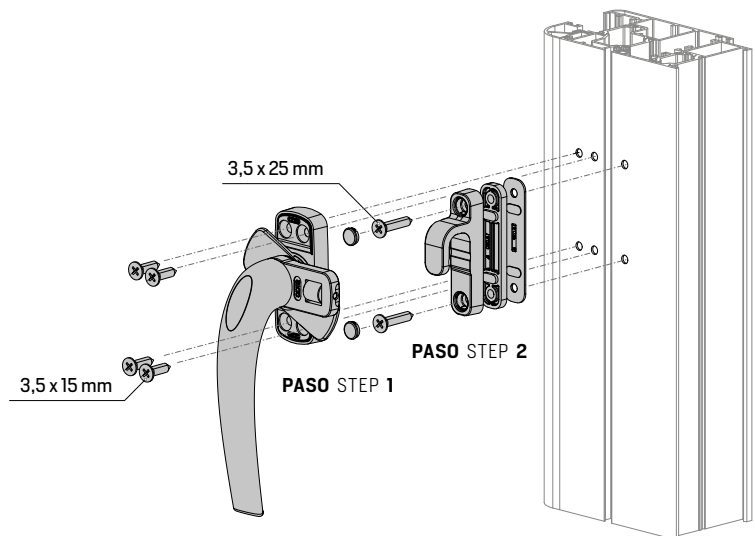
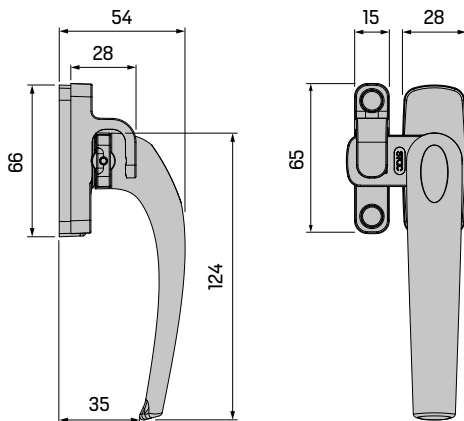

APERTURA EXTERIOR  
OUTWARD OPENING

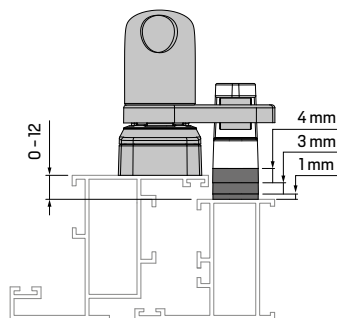

APERTURA INTERIOR  
INWARD OPENING

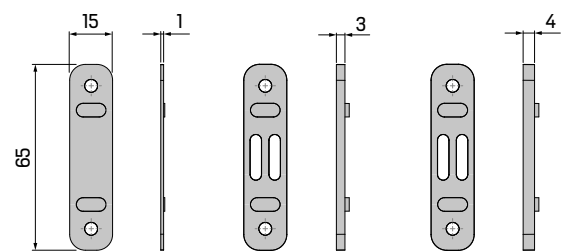

x 2 unidades units    x 2 unidades units    x 1 unidad unit

## CIERRE DE PRESIÓN ORIÓN

### ORION PRESSURE FASTENER

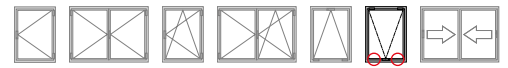

## CIERRE DE PRESIÓN ORIÓN

### ORION PRESSURE FASTENER

150	1	**
	2	

Derecha Right  
Izquierda Left

30



Cierre de presión diseñado para aperturas interiores y exteriores.

- La base del cierre permite un triple posicionamiento del tornillo permitiendo la fijación sin problemas.
- La manilla y los contrcierres disponen de tapas para ocultar los tornillos.
- Las referencias incluyen 3 calzos de 1, 2 y 3 mm permitiendo aumentar la altura desde 1 hasta 6 mm y proporcionar mayor presión al cierre.

Window pressure fastener designed for inward and outward openings.

- The base of the pressure fastener allows a triple positioning of the screw allowing for easy fixing.
- The handle and the counter-locks have covers to hide the screws.
- The references include 3 shims of 1, 2 and 3 mm allowing to increase the height from 1 to 6 mm and to provide more pressure to the fastener.

## CONTRACIERRE ORIÓN PARA APERTURA INTERIOR

### ORION COUNTER-LOCK FOR INWARD OPENING

1503	**
------	----

30

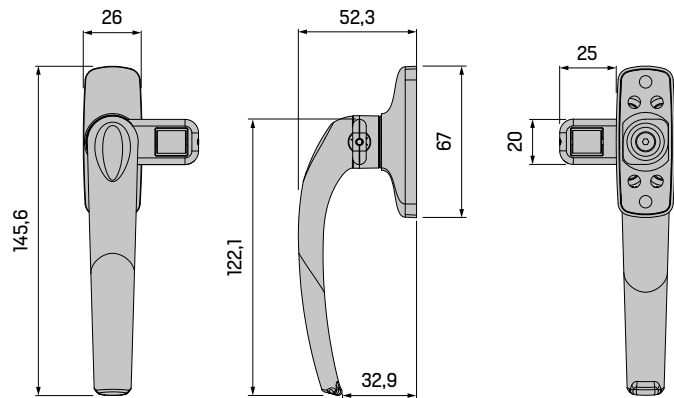

## CONTRACIERRE ORIÓN PARA APERTURA EXTERIOR

### ORION COUNTER-LOCK FOR OUTWARD OPENING

1504	**
------	----

30

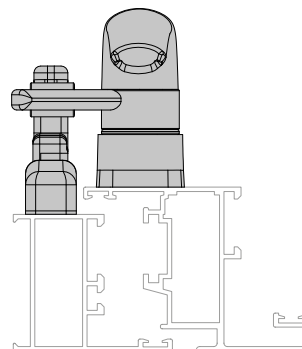

APERTURA EXTERIOR  
OUTWARD OPENING

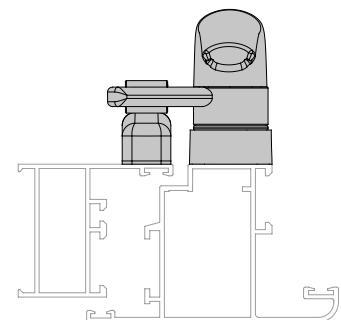

APERTURA INTERIOR  
INWARD OPENING

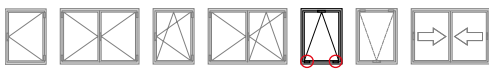

Facade handles designed for bottom-hung opening profiles that allow pressure closing.

Manillas de fachada diseñadas para perfiles de apertura abatible que permiten realizar cierre a presión.

- The handles incorporate two keepers and three pivots to adjust to the different systems.
- The handles are supplied for both right and left-hand openings.

- Las manillas incorporan dos cerraderos y tres pivotes para ajustarse a los diferentes sistemas.
- Las manillas se suministran tanto para aperturas a derecha como a izquierdas.

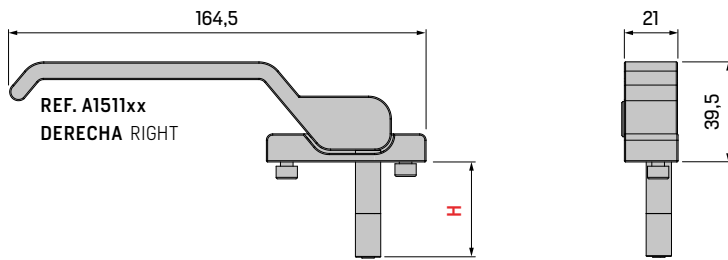

■ **CERRADERO CORTO** SHORT KEEPER

153100

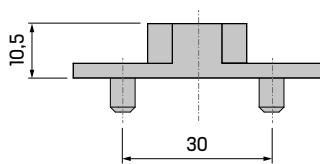

■ **CERRADERO LARGO** LONG KEEPER

153200

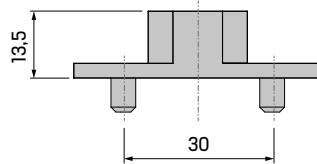

■ **MECANIZADO SUPERIOR (ZONA MANILLA)**  
UPPER MACHINING (HANDLE AREA)

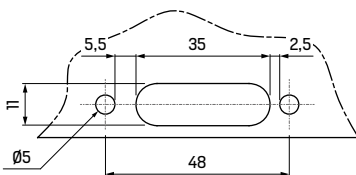

■ **MECANIZADO INFERIOR (ZONA CANAL)**  
LOWER MACHINING (GROOVE AREA)

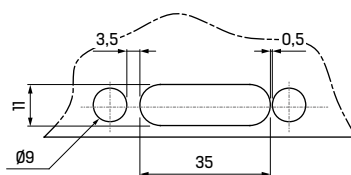

REFERENCIA REFERENCE	DESCRIPCIÓN DESCRIPTION	ALTURA HEIGHT	
153100	<b>CERRADERO CORTO</b> SHORT KEEPER	10,5 mm	50
153200	<b>CERRADERO LARGO</b> LONG KEEPER	13,5 mm	50
154000	<b>PIVOTE MINI</b> MINI PIVOT	25 mm	50
154100	<b>PIVOTE CORTO</b> SHORT PIVOT	28,5 mm	50
154200	<b>PIVOTE LARGO</b> LONG PIVOT	32 mm	50

**MANILLA DE FACHADA CON PIVOTE DE 28,5 mm**  
FACADE HANDLE WITH 28.5 mm PIVOT



Derecha Right  
Izquierda Left

A151	1	**
	2	**

50



REF.	PIVOTE PIVOT	CERRADERO KEEPER
A151	1 2 **	H= 28,5 mm <b>CORTO</b> SHORT 10,5 mm

**Incluye pivote y cerradero** Including pivot and keeper

**MANILLA DE FACHADA CON PIVOTE DE 32 mm**  
FACADE HANDLE WITH 32 mm PIVOT



Derecha Right  
Izquierda Left

A152	1	**
	2	**

50



REF.	PIVOTE PIVOT	CERRADERO KEEPER
A152	1 2 **	H= 32 mm <b>LARGO</b> LONG 13,5 mm

**Incluye pivote y cerradero** Including pivot and keeper

**MANILLA DE FACHADA CON PIVOTE DE 25 mm**  
FACADE HANDLE WITH 25 mm PIVOT



Derecha Right  
Izquierda Left

A153	1	**
	2	**

50



REF.	PIVOTE PIVOT	CERRADERO KEEPER
A153	1 2 **	H= 25 mm <b>CORTO</b> SHORT 10,5 mm

**Incluye pivote y cerradero** Including pivot and keeper

## CIERRE GOLPETE CATCH

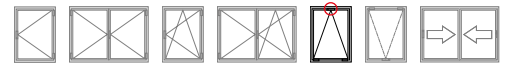

### CIERRE GOLPETE CATCH

1560 \*\*

50



Cierre regulable diseñado para ventanas de apertura abatible con perfiles de Canal Europeo.

- El cierre permite regulación de presión  $\pm 1,5$  mm mediante tornillo prisionero.
- Los pernos de regulación permiten una adaptación perfecta al perfil.
- La instalación del cierre no requiere de ningún tipo de mecanizado en el perfil.

Adjustable lock designed for bottom-hung opening windows with Euro Groove profiles.

- The lock allows  $\pm 1.5$  mm tightening adjustment by means of a set screw.
- The adjustment bolts allow a perfect adaptation to the profile.
- The lock installation does not require any type of machining on the profile.

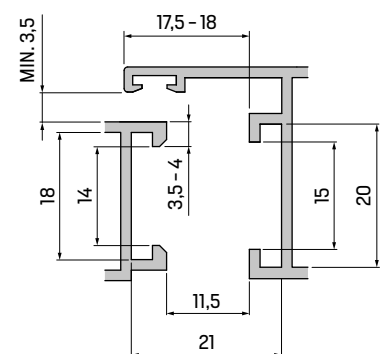
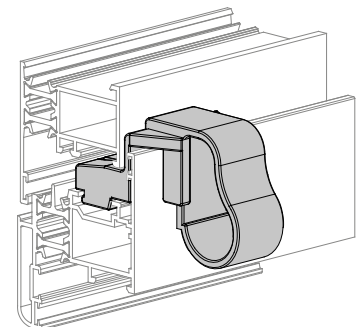
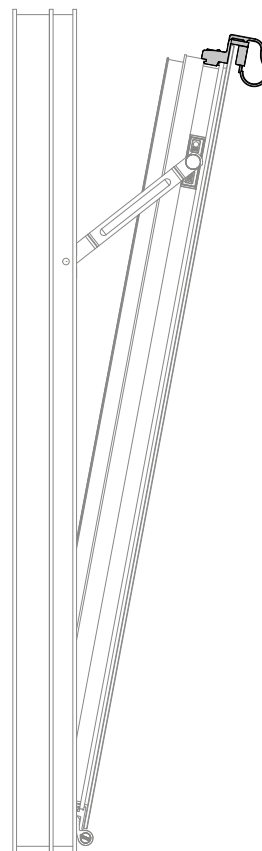
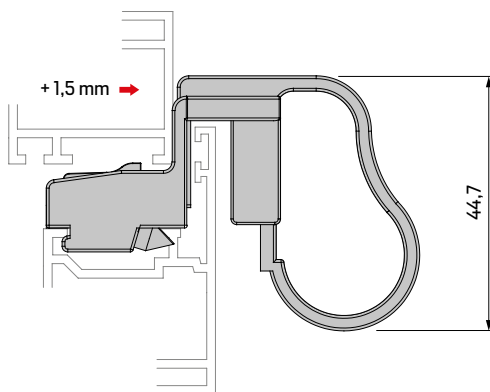
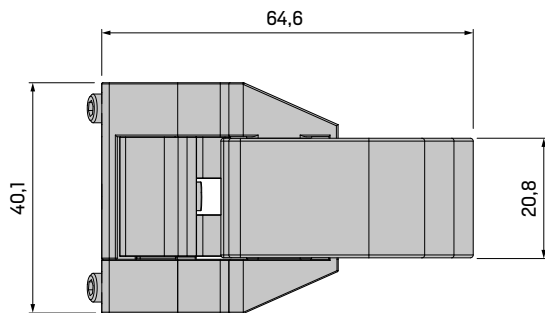

CANAL EUROPEO (EJE 10)  
EURO GROOVE (SHAFT 10)

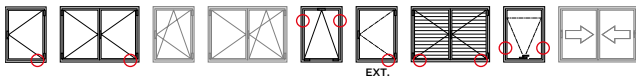

Limiting friction stay with lock.

- The friction stay is compatible with all top-hung and outward openings with Euro Groove profile.
- The lock is operated by the cremone in the limit position.
- It has different degrees of opening according to its position on the sash.
- Access to the unlocking position is by means of a TORX PIN key.
- The friction stay is fixed to the frame profile using self-tapping screws to provide greater security.
- The friction stay is not compatible with the anti-false manoeuvring corner drive with reference 110900.

Compás limitador con bloqueo.

- El compás es compatible con todas las aperturas proyectantes y exteriores con perfil de Canal Europeo.
- El bloqueo es accionado por la cremona en la posición de limitación.
- Dispone de diferentes grados de apertura según su posición en la hoja.
- El acceso a la posición de desbloqueo se realiza mediante una llave TORX PIN.
- La fijación al perfil de marco se realiza mediante tornillos roscachapa para otorgar mayor seguridad.
- El compás no es compatible con el ángulo de reenvío de antifalsa maniobra con referencia 110900.

**COMPÁS LIMITADOR CON BLOQUEO**  
LIMITING FRICTION STAY WITH LOCK



ZM INX



130801

20

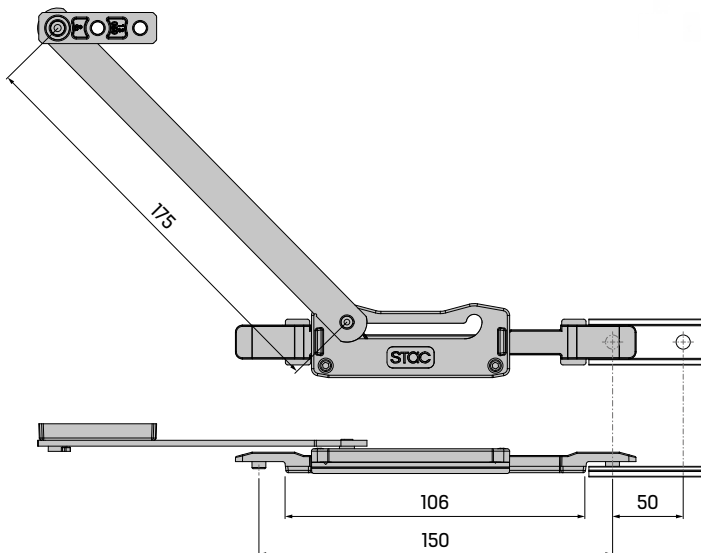

**APERTURAS PRACTICABLES**  
SIDE-HUNG OPENINGS

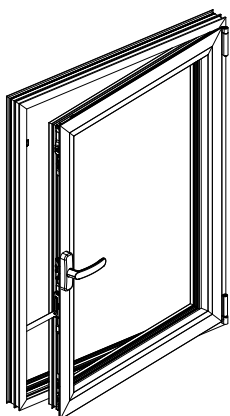

**APERTURAS PROYECTANTES**  
TOP-HUNG OPENINGS

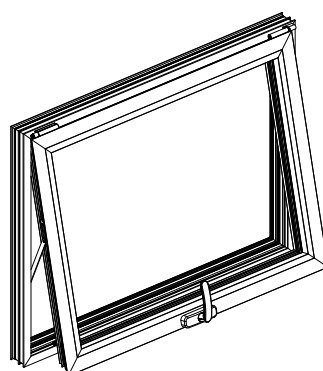

**CONFIGURACIÓN PRACTICABLE**  
SIDE-HUNG CONFIGURATION

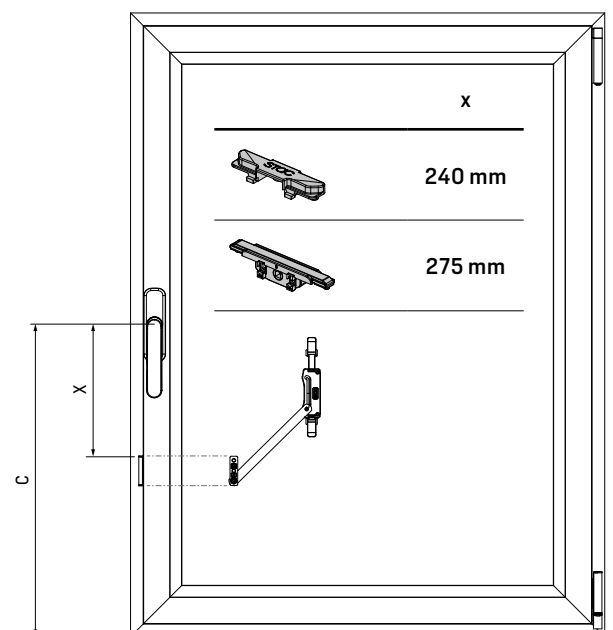

C = altura de la cremona height cremone

## COMPASES LIMITADORES

### LIMITING FRICTION STAYS

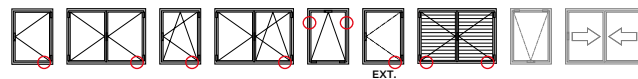

### COMPÁS LIMITADOR CORTO

#### SHORT FRICTION STAY

A130100

40



ZM INX

PA

Compases que permiten limitar la apertura de las ventanas.

- Los compases son válidos para aperturas de ventanas abatibles, practicables y oscilobatientes.
- Los compases disponen de un sistema de freno regulable integrado en la deslizadera.
- Los compases integran una deslizadera de poliamida que permite un funcionamiento más silencioso.
- La posición del tope limitador permite mayor o menos apertura de la hoja.
- La función del compás se anula liberando el tapón roscado.
- Las piezas de zamak han sido tratadas para garantizar resistencia a la corrosión de 240 horas en cámara de niebla salina de acuerdo con lo establecido en la norma UNE-EN 1670 (Grado 4).

Friction stays that allow to limit the opening of the windows.

- The friction stays are valid for bottom-hung, side-hung and tilt & turn window openings.
- The friction stays have an adjustable brake system integrated into the slide system.
- The friction stays have an integrated polyamide slide system for quieter operation.
- The position of the limit stop allows the sash to open more or less.
- The function of the friction stays is cancelled by releasing the screw cap.
- The zamak parts have been treated to guarantee 240 hours of corrosion resistance in a saline mist chamber in accordance with the UNE-EN 1670 standard (Grade 4).

### COMPÁS LIMITADOR LARGO

#### LONG FRICTION STAY

A130101

10



ZM INX

PA

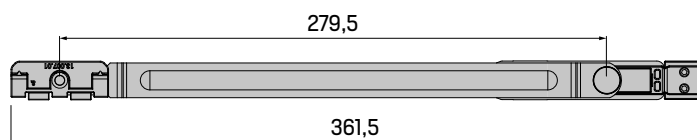
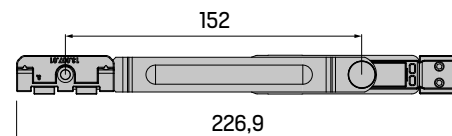

#### FRENO REGULABLE

##### ADJUSTABLE BRAKE

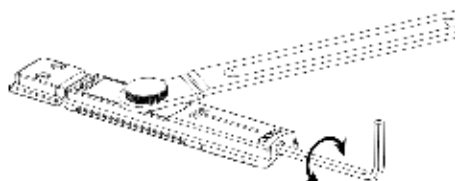

#### APERTURAS OSCILOBATIENTES Y PRACTICABLES

##### TILT & TURN AND SIDE-HUNG OPENING

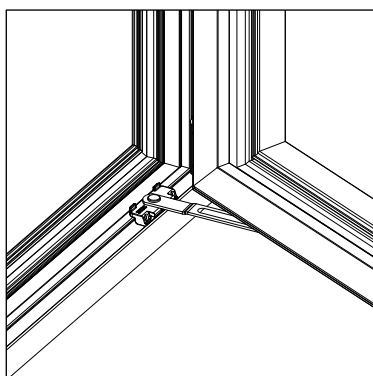

#### APERTURAS ABATIBLES

##### BOTTOM-HUNG OPENINGS

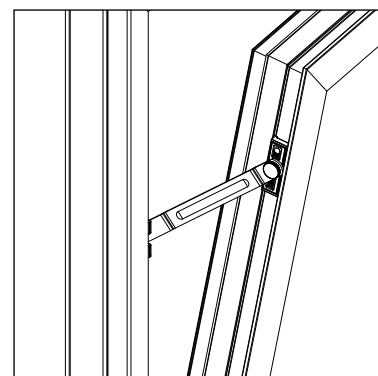



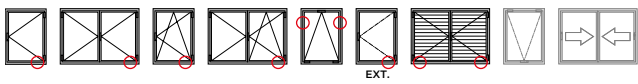

Friction stays that allow to limit and retain the opening of the windows.

- The friction stays are valid for bottom-hung, side-hung and tilt & turn window openings.
- The retention position is carried out in the window's limiting position.
- They have an integrated security system that allows access to the unlocking by means of a TORX PIN key.
- The friction stays have an adjustable brake system integrated into the slide system.
- The zamak parts have been treated to guarantee 240 hours of corrosion resistance in a saline mist chamber in accordance with the UNE-EN 1670 standard (Grade 4).

Compases que permiten limitar y retener la apertura de las ventanas.

- Los compases son válidos para aperturas de ventanas abatibles, practicables y oscilobatientes.
- La retención se realiza en la posición de limitación de la ventana.
- Disponen de un sistema de seguridad integrado que permite el acceso al desbloqueo mediante llave TORX PIN.
- Los compases disponen de un sistema de freno regulable integrado en la deslizadora.
- Las piezas de zamak han sido tratadas para garantizar resistencia a la corrosión de 240 horas en cámara de niebla salina de acuerdo con lo establecido en la norma UNE-EN 1670 (Grado 4).

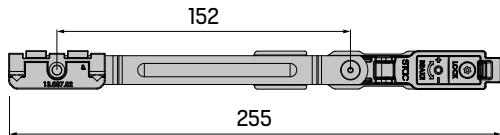

REF. 130120  
L min. = 290 mm  
REF. 130121  
L min. = 420 mm

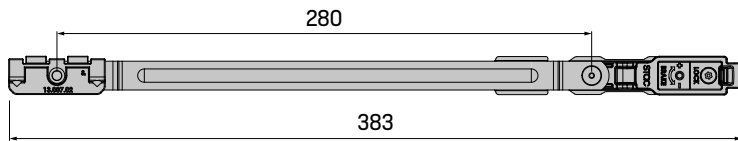

REF. 130120  
 $\alpha$  max. = 90°  
REF. 130121  
 $\alpha$  max. = 130°

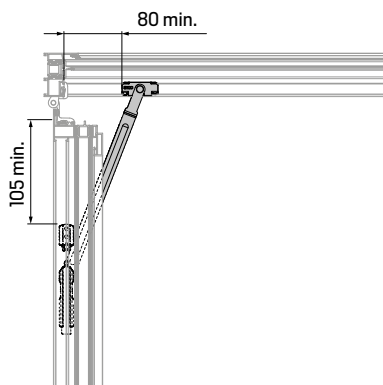
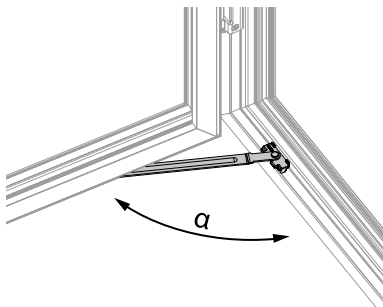

REF. 130120  
B = 80 mm  
REF. 130121  
B = 125 mm

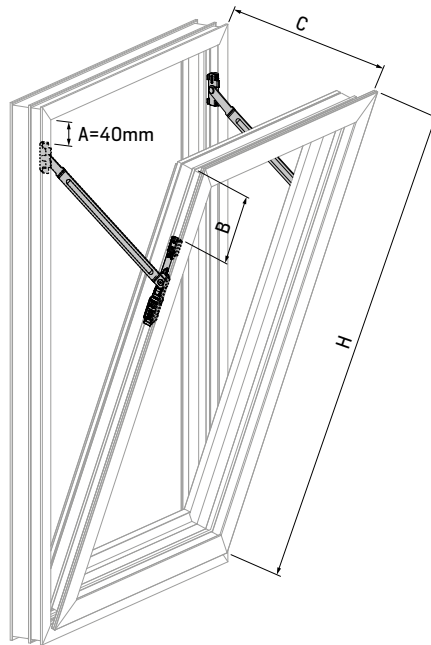

**COMPÁS LIMITADOR RS CORTO**  
SHORT RS LIMITING FRICTION STAY



130120



**COMPÁS LIMITADOR RS LARGO**  
LONG RS LIMITING FRICTION STAY



130121



**AP. PRACTICABLE**  
SIDE-HUNG OPENING



**AP. OSCILOBIENTE**  
TILT & TURN OPENING

□ 130120  
■ 130120 | 130121  
▨ NO REALIZABLE NOT POSSIBLE

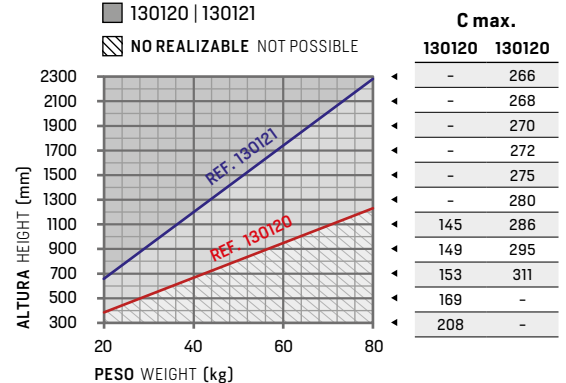

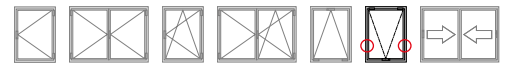

**COMPÁS LIMITADOR EXTENSIBLE**  
EXTENDABLE FRICTION STAY

18009

15

INX

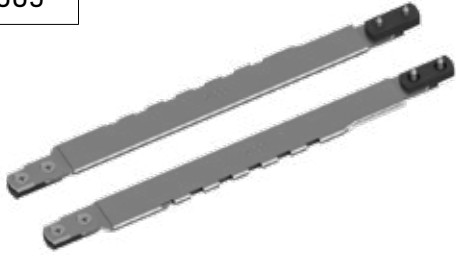

Compás limitador diseñado para ventanas de apertura proyectante.

Limiting friction stay designed for top-hung opening windows.

- El compás es válido para ventanas de apertura proyectante, series con perfil 40 / 20 y de Canal Europeo.
- El compás limitador permite la apertura en 5 posiciones definidas.
- La apertura de la ventana es regulable con posicionado.
- Para cerrar la ventana es necesario colocar el compás en posición de máxima apertura.

- The friction stay is valid for top-hung opening windows, series with 40 / 20 profile and Euro Groove.
- The limiting friction stay allows the opening in 5 defined positions.
- The window opening is adjustable with positioning.
- To close the window it is necessary to place the friction stay in the maximum opening position.

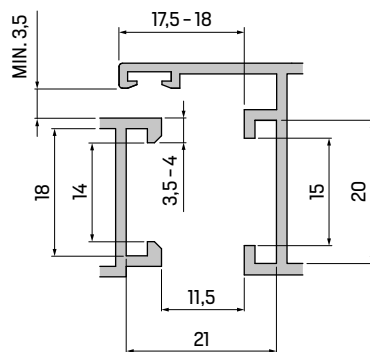
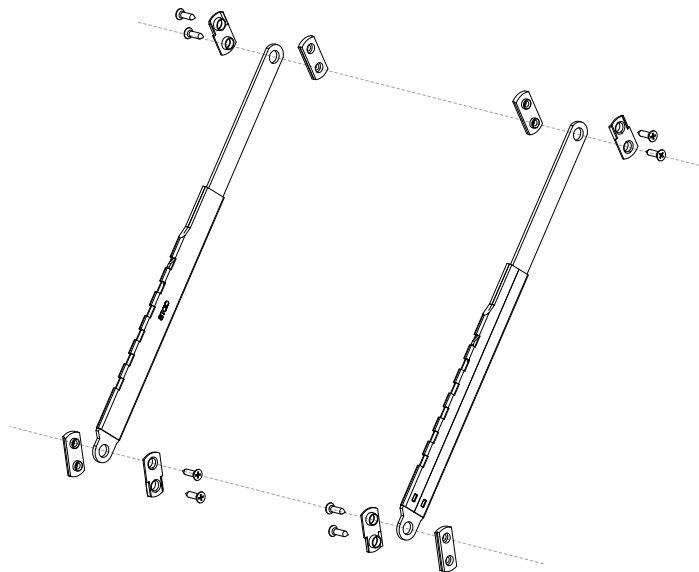
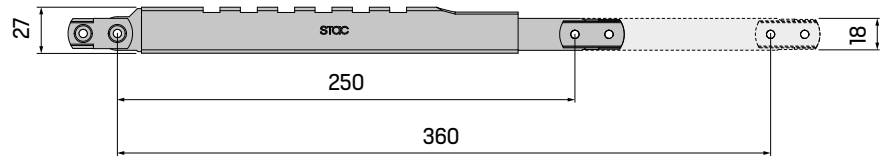
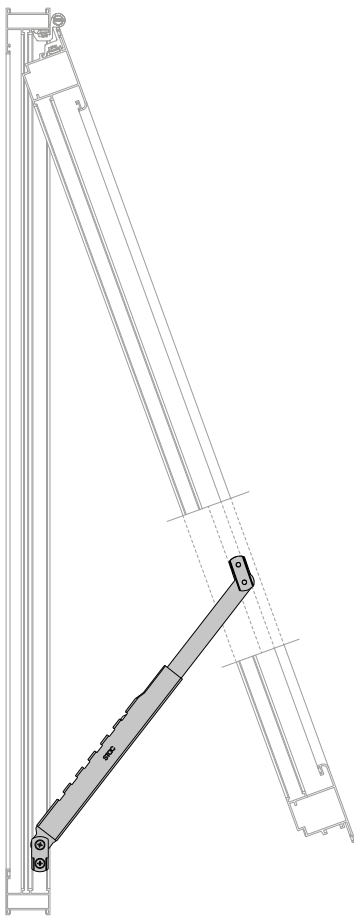

CANAL EUROPEO (EJE 10)  
EURO GROOVE (SHAFT 10)

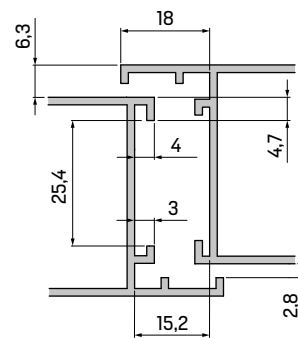

SERIES 6000  
6000 SERIES

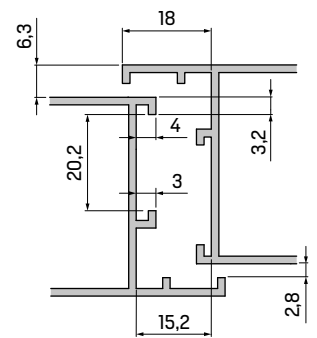

SERIES 4000  
4000 SERIES

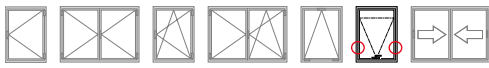

Friction stay with limitation specially designed for top-hung windows.

Compás con limitación diseñado especialmente para ventanas proyectantes.

- The use of standard limiting friction stays is recommended as additional elements to the top-hung friction stays from 1800 mm sash height.
- The use of limiting friction stays is recommended in areas exposed to strong winds or with restrictions on the limitation of opening.

- Se recomienda el uso de compases limitadores estándar como elementos adicionales a los compases proyectantes a partir de 1800 mm de altura de la hoja.
- Es recomendable el uso de compases limitadores en áreas expuestas a fuertes vientos o con restricciones en la limitación de la apertura.

**COMPÁS LIMITADOR INOX**  
STAINLESS STEEL LIMITING FRICTION STAY

INX

18010

25

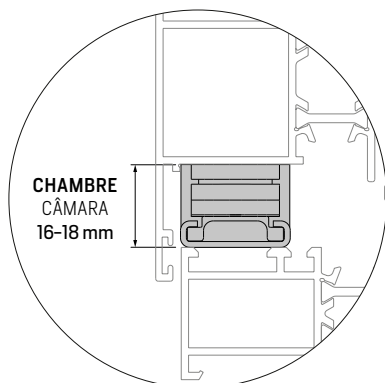
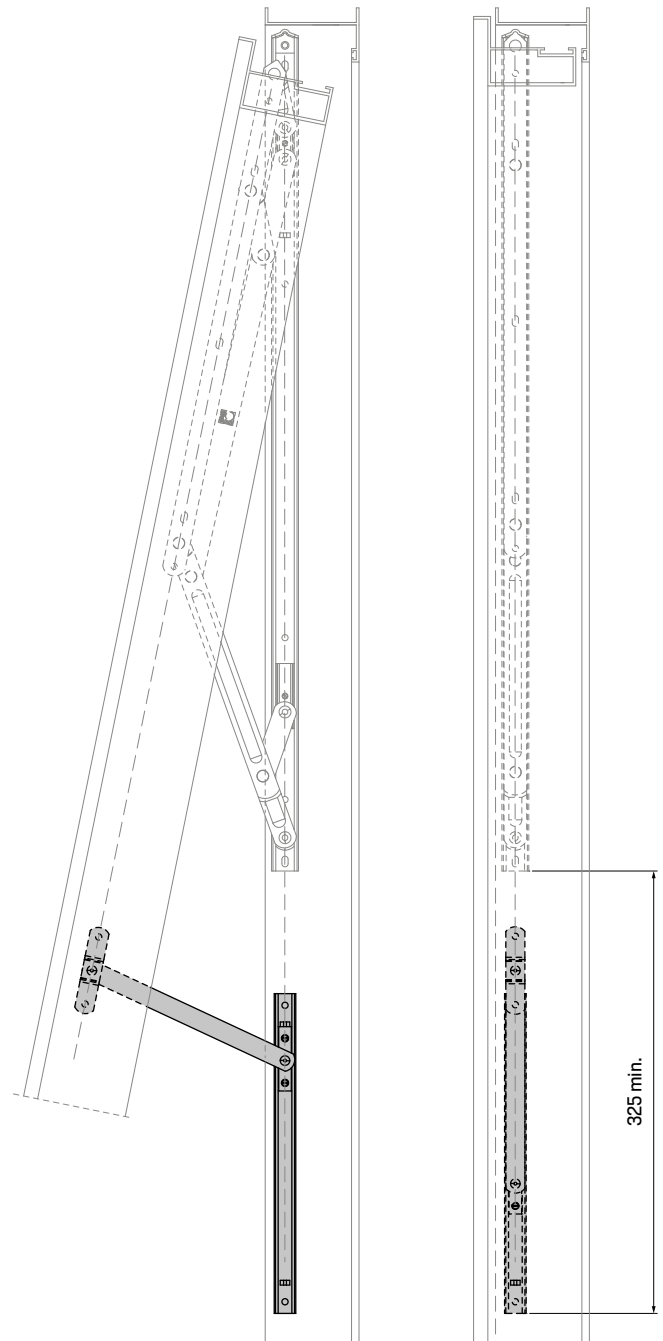
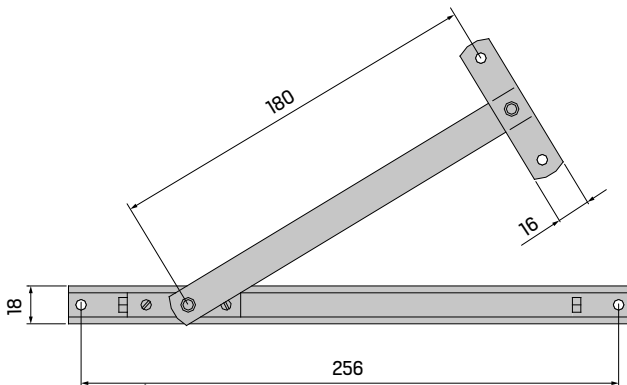

# COMPASES PARA APERTURA PROYECTANTE

TOP-HUNG OPENING FRICTION STAYS

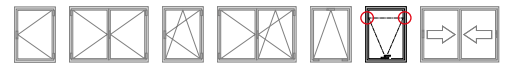

## COMPASES PROYECTANTES

TOP-HUNG FRICTION STAYS

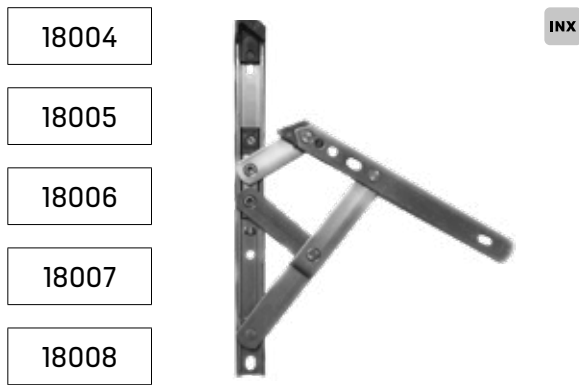

Compases con limitación especialmente diseñados para ventanas proyectantes.

Friction stays with limitation specially designed for top-hung windows.

- Los compases son válidos para perfiles de ventana con cámara de 16 / 18 mm.
- Los compases limitadores se suministran en juegos de 2 unidades.
- Los compases incorporan un patín que permite regulación de presión.
- No son compatibles con el regulador de altura con referencia 18200.

- The friction stays are valid for window profiles with 16 / 18 mm chamber.
- The limiting friction stays are supplied in sets of 2 units.
- The limiting friction stays incorporate a skid that allows pressure adjustment.
- They are not compatible with the height adjuster with reference 18200.

REFERENCIA REFERENCE	LONGITUD LENGTH	ANCHO WIDTH	ALTURA HEIGHT	PESO MÁX. MAX. WEIGHT	ÁNG. DE APERTURA OPENING ANGLE	MATERIAL MATERIAL	
18004	200 mm	1200 mm	350 mm	12 kg	70°	AISI 304	25
18005	300 mm	1200 mm	550 mm	20 kg	87°	AISI 304	25
18006	400 mm	1200 mm	750 mm	24 kg	87°	AISI 304	25
18007	500 mm	1200 mm	1000 mm	28 kg	40°	AISI 304	25
18008	600 mm	1200 mm	1100 mm	35 kg	40°	AISI 304	25

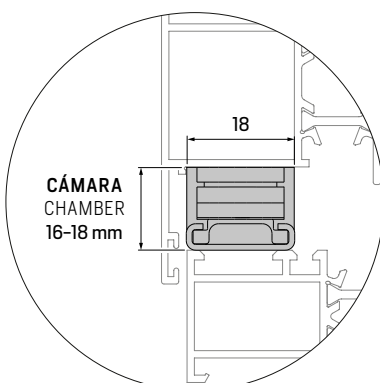
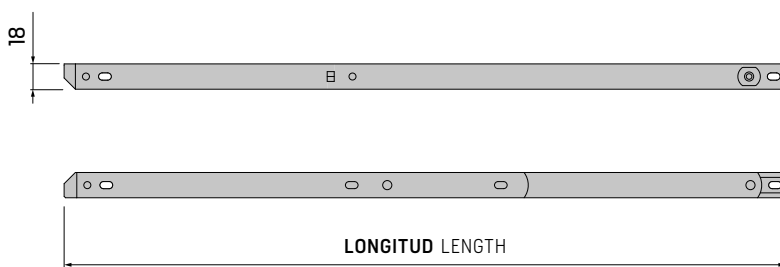

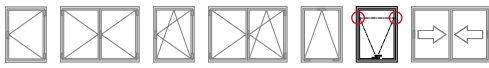

## COMPASES PARA APERTURA PROYECTANTE

### TOP-HUNG OPENING FRICTION STAYS

Reinforced friction stays with limitation designed for top-hung windows.

- The friction stays are valid for window profiles with 16 / 18 mm chamber.
- The limiting friction stays are supplied in sets of 2 units.
- The limiting friction stays incorporate a skid that allows pressure adjustment.

Compases reforzados con limitación diseñados para ventanas proyectantes.

- Los compases son válidos para perfiles de ventana con cámara de 16 / 18 mm.
- Los compases limitadores se suministran en juegos de 2 unidades.
- Los compases incorporan un patín que permite regulación de presión.

## COMPASES PROYECTANTES REFORZADOS

### REINFORCED TOP-HUNG FRICTION STAYS

INX



18001

18002

18003

REFERENCIA REFERENCE	LONGITUD LENGTH	ANCHO WIDTH	ALTURA HEIGHT	PESO MÁX. MAX. WEIGHT	ÁNG. DE APERTURA OPENING ANGLE	MATERIAL MATERIAL	
18001	250 mm	1200 mm	550 mm	20 kg	87°	AISI 304	25
18002	400 mm	1200 mm	900 mm	30 kg	87°	AISI 304	25
18003	550 mm	1200 mm	1300 mm	40 kg	87°	AISI 304	25

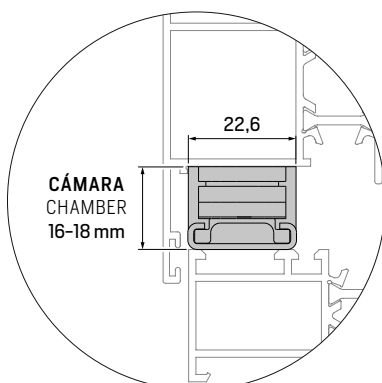

## COMPASES PARA APERTURA PROYECTANTE

TOP-HUNG OPENING FRICTION STAYS

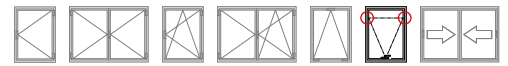

## COMPASES PARA MURO CORTINA

CURTAIN WALL FRICTION STAYS

A18011

A18012

A18017

A18018



INX

Compases con limitación especialmente diseñados para muro cortina.

- Los compases son válidos para perfiles de ventana con cámara de 16 / 18 mm.
- Los compases limitadores se suministran en juegos de 2 unidades.
- Los compases incorporan un patín que permite regulación de presión.
- El compás con referencia A180011 incorpora limitación de apertura.
- El compás con referencia A180012 permite la instalación de la pletina limitadora de apertura (ref. 0518014).
- Se recomienda la utilización del regulador de altura con referencia 18200 en hojas con alturas mayores a 1000 mm.

Friction stays with limitation specifically designed for curtain wall.

- The friction stays are valid for window profiles with 16 / 18 mm chamber.
- The limiting friction stays are supplied in sets of 2 units.
- The limiting friction stays incorporate a skid that allows pressure adjustment.
- The friction stay with reference A180011 has an opening limitation.
- The friction stay with reference A180012 allows the installation of the opening limiting plate (ref. 0518014).
- We recommend the use of the height adjuster with reference 18200 on sashes with heights greater than 1000 mm.

REFERENCIA REFERENCE	LONGITUD LENGTH	ANCHO WIDTH	ALTURA HEIGHT	PESO MÁX. MAX. WEIGHT	ÁNG. DE APERTURA OPENING ANGLE	MATERIAL MATERIAL	
A18011	455 mm	500 - 1500 mm	500 - 1200 mm	80 kg	30° / 25° *	AISI 304	20
B18011	455 mm	500 - 1500 mm	500 - 1200 mm	80 kg	30° / 25° *	AISI 316	20
A18012	705 mm	500 - 2200 mm	1200 - 2200 mm	130 kg	20° / 15° * / 10°*	AISI 304	20
B18012	705 mm	500 - 2200 mm	1200 - 2200 mm	130 kg	20° / 15° * / 10°*	AISI 316	20
A18017	555 mm	500 - 1800 mm	600 - 1800 mm	110 kg	20° / 25° *	AISI 304	20
A18018	600 mm	500 - 1800 mm	650 - 1800 mm	120 kg	15° / 20° *	AISI 304	20

\* Con limitación de apertura With opening limitation

## DISPOSITIVO DE REGULACIÓN DE ALTURA

HEIGHT ADJUSTMENT DEVICE

18200

100

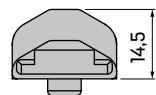

ZM INX

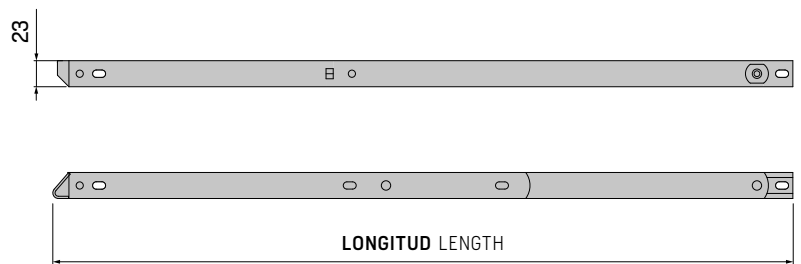

## PLETINA LIMITADORA PARA COMPÁS GRANDE

LIMITING PLATE FOR LARGE FRICTION STAY

A0518014

100

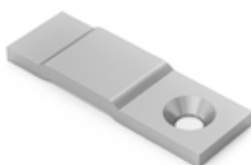

ZM INX

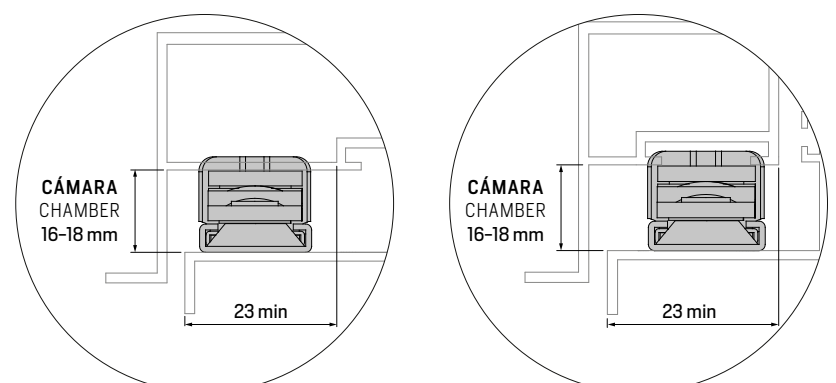



Locking points designed for profile series with Euro Groove.

Puntos de cierre diseñados para series de perfil con Canal Europeo.

#### Adjustable locking point

- Frame element for locking point with tightening adjustment.

#### Punto de cierre regulable

- Elemento de marco para punto de cierre que permite regulación de apriete.

#### Concealed locking point

- Supplementary locking point for top-hung window sashes.
- The use of the concealed locking point is recommended from 1200 mm sash height.

#### Punto de cierre oculto

- Punto de cierre suplementario para hojas de apertura proyectante.
- Se recomienda el uso del punto de cierre oculto a partir de 1200 mm de altura de hoja.

#### Supplementary locking point kit

- Kit consisting of an adjustable keeper and a sliding locking point that acts as a supplementary locking point.

#### Kit punto de cierre suplementario

- Kit compuesto por un cerradero regulable y un punto de cierre deslizador que funcionan como cierre suplementario.

### PUNTO DE CIERRE REGULABLE ADJUSTABLE LOCKING POINT



110200

500



### PUNTO DE CIERRE OCULTO CONCEALED LOCKING POINT



112500

50



### KIT PUNTO DE CIERRE SUPLEMENTARIO SUPPLEMENTARY LOCKING POINT KIT



113000

50



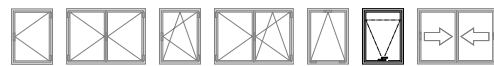

**KIT ÁNGULO DE REENVÍO HORIZONTAL**

HORIZONTAL CORNER DRIVE KIT

113420



ZM INX

20



Accesorios compatibles con sistemas de ventana de apertura proyectante.

Accessories compatible with top-hung opening window systems.

**Ángulo de reenvío horizontal**

- El ángulo de reenvío permite transmitir el movimiento a 90º del herraje de la zona inferior a la superior.

**Horizontal corner drive**

- The corner driver allows the 90º movement of the hardware to be transmitted from the lower to the upper area.

**Funda de transmisión**

- Elemento acanalado al perfil que permite conectar la pala de transmisión de las cremonas con las pletinas fallebas.

**Transmission cover**

- Profile grooved element which allows to connect the transmission lever of the cremone with the rod plates.

**FUNDA DE TRANSMISIÓN**

TRANSMISSION COVER

180100



ZM INX

50



**FALLEBA DE TRANSMISIÓN**

TRANSMISSION ROD

18016



AL

100







Accessories compatible with top-hung opening window systems with flat-frame profiles.

Accesorios compatibles con sistemas de ventana con perfiles de marco plano de apertura proyectante.

**Adjustable locking point**

- Flat frame element for locking point with  $\pm 3$  mm adjustment.
- It is supplied with 1 and 2 mm shims that allow for height adjustment in relation to the profile.

**Punto de cierre regulable**

- Elemento de marco plano para punto de cierre con regulación de  $\pm 3$  mm.
- Se suministra con calzos de 1 y 2 mm respectivamente que permiten regular la altura en relación al perfil.

**Concealed locking point**

- Supplementary locking point for top-hung window sashes.
- The use of the curtain wall concealed locking point is recommended from 1200 mm sash height.

**Punto de cierre oculto**

- Punto de cierre suplementario para hojas de apertura proyectante.
- Se recomienda el uso del punto de cierre oculto para muro cortina a partir de 1200 mm de altura de hoja.

**PUNTO DE CIERRE REGULABLE**  
ADJUSTABLE LOCKING POINT



180200



**KIT PUNTO DE CIERRE REGULABLE**  
ADJUSTABLE LOCKING POINT KIT



183000



**PUNTO DE CIERRE OCULTO PARA MURO CORTINA**  
CURTAIN WALL CONCEALED LOCKING POINT



0518015



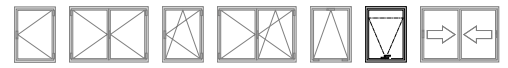

» **CIERRE PERIMETRAL DE 10 PUNTOS** 10 POINTS PERIMETER LOCKING

**CONFIGURACIÓN PARA MARCO PLANO**  
FLAT FRAME CONFIGURATION



	1161	**	<b>CREMONA ACODADA SIRIUS</b> SIRIUS OFFSET CREMONE	
1	1166	**	<b>CREMONA SIRIUS</b> SIRIUS CREMONE	20
	A1167	**	<b>CREMONA SIRIUS BLOC</b> SIRIUS BLOCK CREMONE	
2	180100		<b>FUNDA DE TRANSMISIÓN</b> TRANSMISSION COVER	50
3	183000		<b>KIT PUNTO DE CIERRE REGULABLE</b> ADJUSTABLE LOCKING POINT KIT	50
4	0518015		<b>PTO. DE CIERRE OCULTO MURO CORTINA</b> CURTAIN WALL CONCEALED LOCKING POINT	100
5	183500		<b>KIT DE CIERRE PERIMETRAL</b> PERIMETER LOCKING KIT	10
	A18011		<b>COMPÁS MURO CORTINA PEQUEÑO</b> SMALL CURTAIN WALL FRICTION STAY	
6	A18012		<b>COMPÁS MURO CORTINA GRANDE</b> LARGE CURTAIN WALL FRICTION STAY	20
7	18200		<b>DISPOSITIVO DE REGULACIÓN DE ALTURA</b> HEIGHT ADJUSTMENT DEVICE	100
8	A0518014		<b>PLETINA LIMITADORA PARA COMPÁS GRANDE</b> LIMITING PLATE FOR LARGE FRICTION STAY	100
9	18010		<b>COMPÁS LIMITADOR</b> LIMITING FRICTION STAY	25

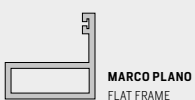
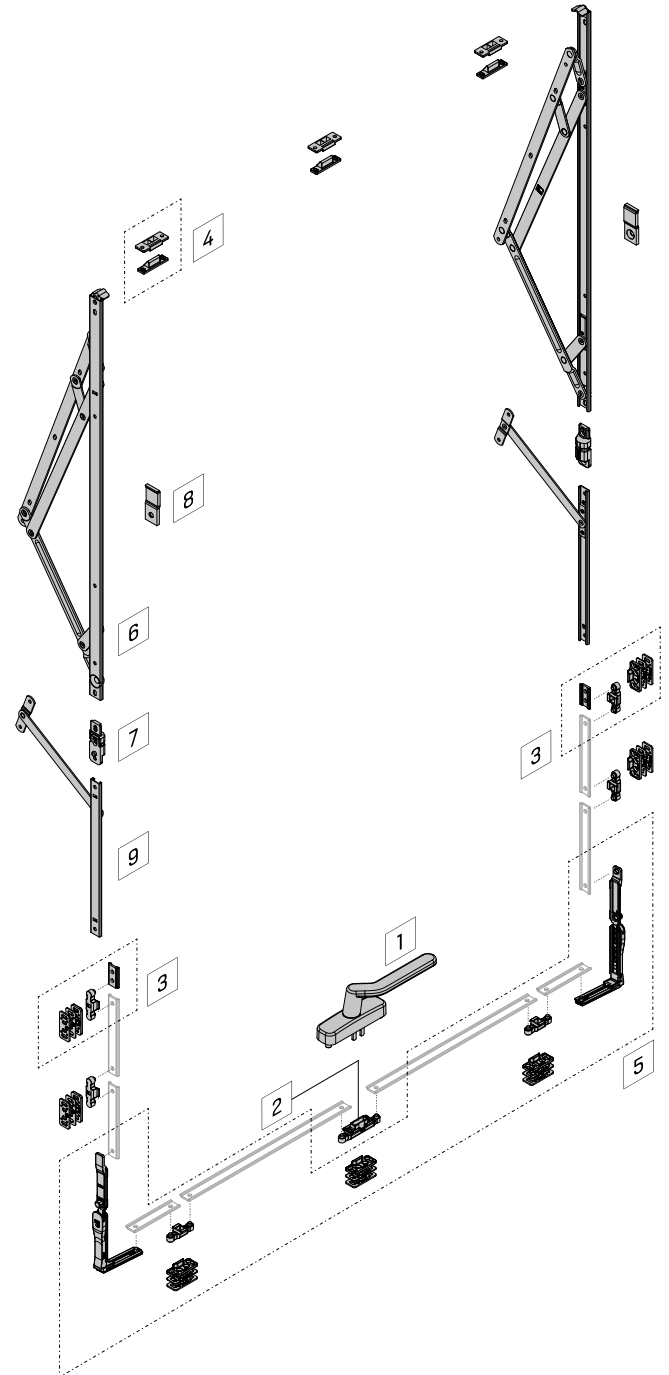

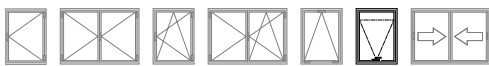

## CONFIGURACIÓN PROYECTANTE PARA MARCO PLANO TOP-HUNG OPENING CONFIGURATION FOR FLAT FRAME

### » CIERRE PERIMETRAL DE 4 PUNTOS 4 POINTS PERIMETER LOCKING

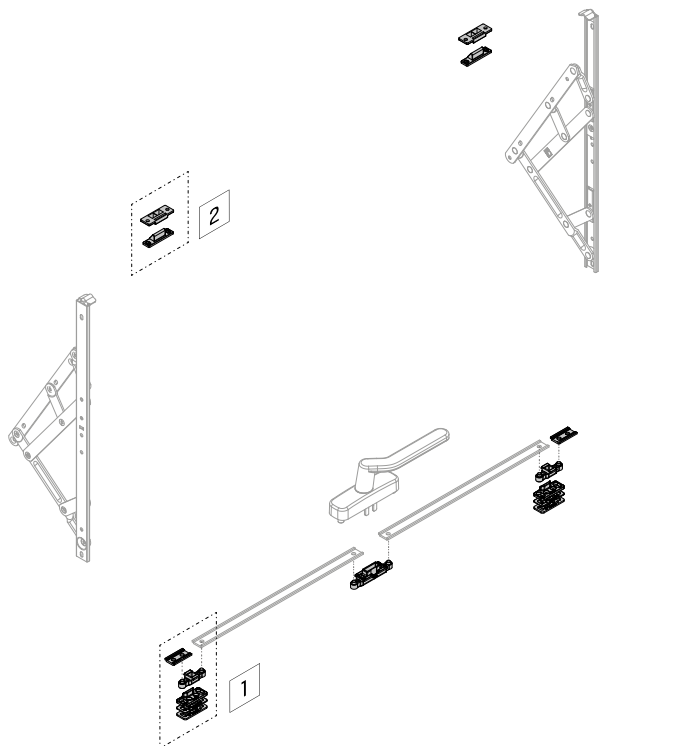

#### CONFIGURACIÓN PARA MARCO PLANO FLAT FRAME CONFIGURATION



1	<b>183000</b>	<b>KIT PUNTO DE CIERRE REGULABLE</b> ADJUSTABLE LOCKING POINT KIT	50
2	<b>0518015</b>	<b>PTO. DE CIERRE OCULTO MURO CORTINA</b> CURTAIN WALL CONCEALED LOCKING POINT	100
3	<b>180100</b>	<b>FUNDA DE TRANSMISIÓN</b> TRANSMISSION COVER	50

Ver compases proyectantes compatibles en las páginas 238-240.

View compatible top-hung window friction stays on pages 238-240.

### » CIERRE PERIMETRAL DE 6 PUNTOS 6 POINTS PERIMETER LOCKING

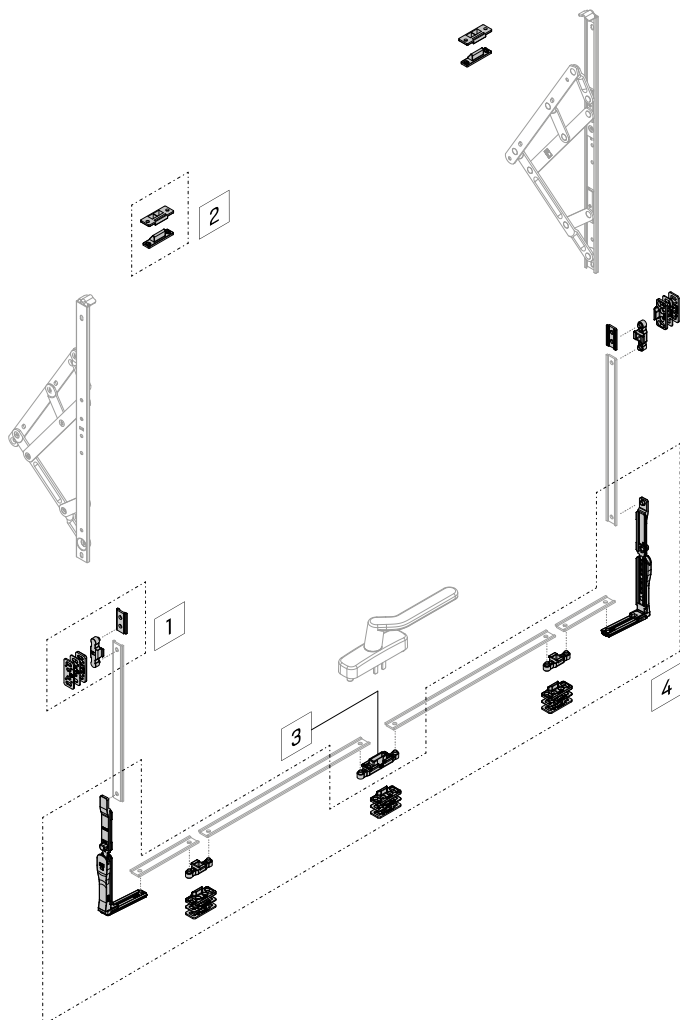

#### CONFIGURACIÓN PARA MARCO PLANO FLAT FRAME CONFIGURATION



1	<b>183000</b>	<b>KIT PUNTO DE CIERRE REGULABLE</b> ADJUSTABLE LOCKING POINT KIT	50
2	<b>0518015</b>	<b>PTO. DE CIERRE OCULTO MURO CORTINA</b> CURTAIN WALL CONCEALED LOCKING POINT	100
3	<b>180100</b>	<b>FUNDA DE TRANSMISIÓN</b> TRANSMISSION COVER	50
4	<b>183500</b>	<b>KIT DE CIERRE PERIMETRAL</b> PERIMETER LOCKING KIT	10

Ver compases proyectantes compatibles en las páginas 238-240.

View compatible top-hung window friction stays on pages 238-240.

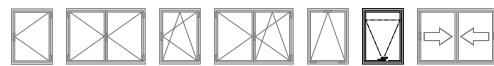

» **CIERRE PERIMETRAL DE 10 PUNTOS** 10 POINTS PERIMETER LOCKING

**CONFIGURACIÓN PARA MARCO DE CANAL EUROPEO**

EURO GROOVE FRAME CONFIGURATION



	<b>1161</b>	**	<b>CREMONA ACODADA SIRIUS</b> SIRIUS OFFSET CREMONE	
1	<b>1166</b>	**	<b>CREMONA SIRIUS</b> SIRIUS CREMONE	20
	<b>A1167</b>	**	<b>CREMONA SIRIUS BLOCK</b> SIRIUS BLOCK CREMONE	
2	<b>180100</b>		<b>FUNDA DE TRANSMISIÓN</b> TRANSMISSION COVER	50
3	<b>0518015</b>		<b>PTO. DE CIERRE OCULTO MURO CORTINA</b> CURTAIN WALL CONCEALED LOCKING POINT	100
4	<b>113420</b>		<b>KIT ÁNGULO DE REENVÍO HORIZONTAL</b> HORIZONTAL CORNER DRIVE KIT	20
5	<b>112500</b>		<b>PUNTO DE CIERRE OCULTO</b> CONCEALED LOCKING POINT	50
6	<b>110200</b>		<b>PUNTO DE CIERRE REGULABLE</b> ADJUSTABLE LOCKING POINT	500
7	<b>113000</b>		<b>KIT PUNTO DE CIERRE SUPLEMENTARIO</b> SUPPLEMENTARY LOCKING POINT KIT	50
8	<b>0517193</b>		<b>RESBALÓN DE POSICIONAMIENTO</b> POSITIONING LATCH	100
	<b>A18011</b>		<b>COMPÁS MURO CORTINA PEQUEÑO</b> SMALL CURTAIN WALL FRICTION STAY	
9	<b>A18012</b>		<b>COMPÁS MURO CORTINA GRANDE</b> LARGE CURTAIN WALL FRICTION STAY	20
10	<b>18200</b>		<b>DISPOSITIVO DE REGULACIÓN DE ALTURA</b> HEIGHT ADJUSTMENT DEVICE	100
11	<b>A0518014</b>		<b>PLETINA LIMITADORA PARA COMPÁS GRANDE</b> LIMITING PLATE FOR LARGE FRICTION STAY	100
12	<b>18010</b>		<b>COMPÁS LIMITADOR</b> LIMITING FRICTION STAY	25

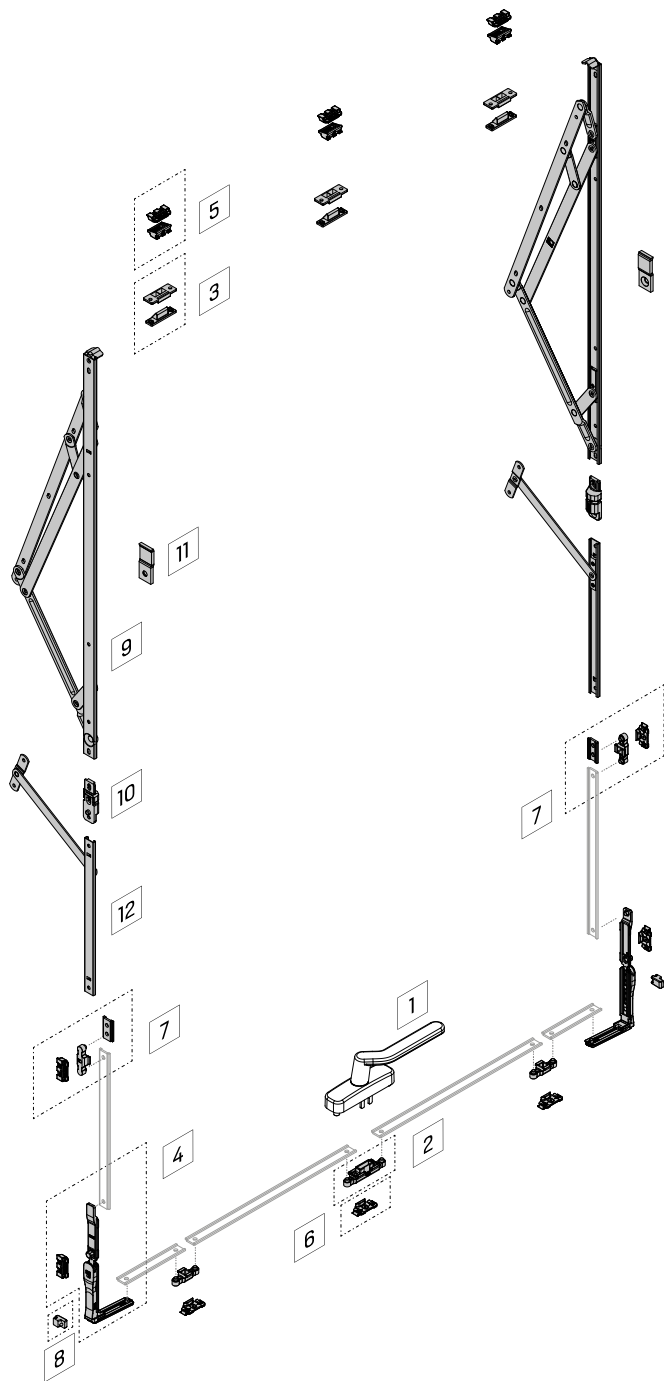

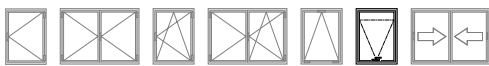

## CONFIGURACIÓN PROYECTANTE PARA MARCO DE CANAL EUROPEO

### TOP-HUNG OPENING CONFIGURATION FOR EURO GROOVE FRAME

#### » CIERRE PERIMETRAL DE 4 PUNTOS 4 POINTS PERIMETER LOCKING

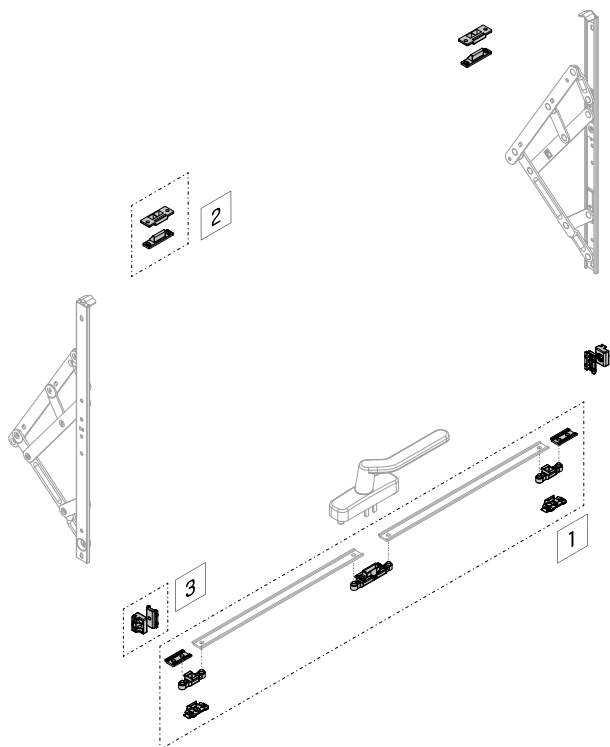

#### CONFIGURACIÓN PARA MARCO DE CANAL EUROPEO

##### EURO GROOVE FRAME CONFIGURATION



1	<b>182400</b>	<b>KIT PUNTO DE CIERRE INFERIOR</b> LOWER LOCKING POINT KIT	25
2	<b>0518015</b>	<b>PTO. DE CIERRE OCULTO MURO CORTINA</b> CURTAIN WALL CONCEALED LOCKING POINT	100
3	<b>0710621</b>	<b>KIT RESBALÓN DE POSICIONAMIENTO</b> POSITIONING LATCH KIT	100

Ver compases proyectantes compatibles en las páginas 238-240.

View compatible top-hung window friction stays on pages 238-240.

#### » CIERRE PERIMETRAL DE 6 PUNTOS 6 POINTS PERIMETER LOCKING

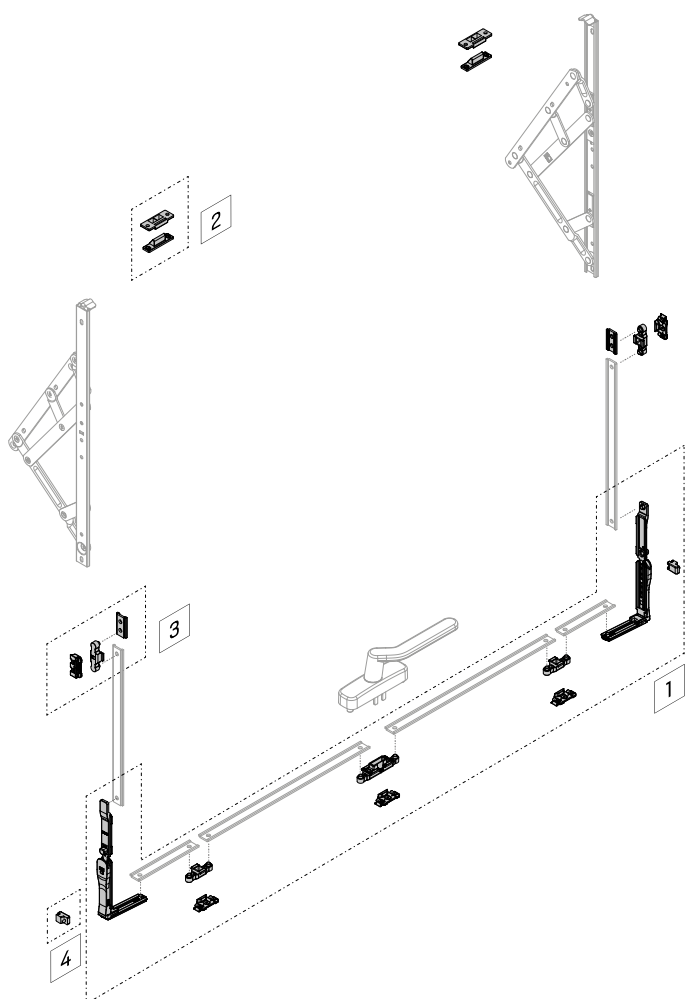

#### CONFIGURACIÓN PARA MARCO DE CANAL EUROPEO

##### EURO GROOVE FRAME CONFIGURATION



1	<b>183400</b>	<b>KIT DE CIERRE PERIMETRAL</b> PERIMETER LOCKING KIT	10
2	<b>0518015</b>	<b>PTO. DE CIERRE OCULTO MURO CORTINA</b> CURTAIN WALL CONCEALED LOCKING POINT	100
3	<b>113000</b>	<b>KIT PUNTO DE CIERRE SUPLEMENTARIO</b> SUPPLEMENTARY LOCKING POINT KIT	50
4	<b>0517193</b>	<b>RESBALÓN DE POSICIONAMIENTO</b> POSITIONING LATCH	-

Ver compases proyectantes compatibles en las páginas 238-240.

View compatible top-hung window friction stays on pages 238-240.



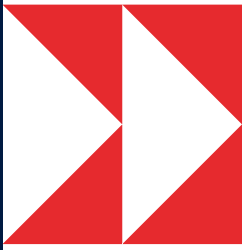

# 12

## **CONTRAVENTANAS** WINDOW SHUTTERS

250

### **Cierre de presión PEGASO**

PEGASO pressure fastener

250

### **Bisagra PEGASO**

PEGASO hinge



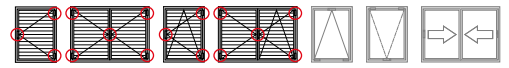

**CIERRE DE PRESIÓN PEGASO**  
PEGASO PRESSURE FASTENER

100002 \*\*

25



Cierre de presión y bisagra ambidiestra PEGASO para contras de ventana.

- El cierre PEGASO admite múltiple posicionamiento con el objetivo de adaptarse a diferentes sistemas por medio de distanciadores simétricos que permiten un ajuste perfecto en su instalación.
- Carga máxima con 2 bisagras: 50 kg.

PEGASO pressure lock and ambidextrous hinge for window shutters.

- The PEGASO pressure lock allows multiple positioning in order to adapt to different systems by means of symmetrical spacers that allow a perfect fit in its installation.
- Maximum load with 2 hinges: 50 kg.

**BISAGRA PEGASO**  
PEGASO HINGE

100001 \*\*

50

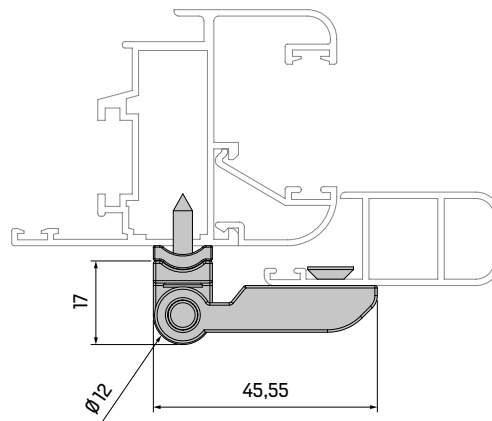
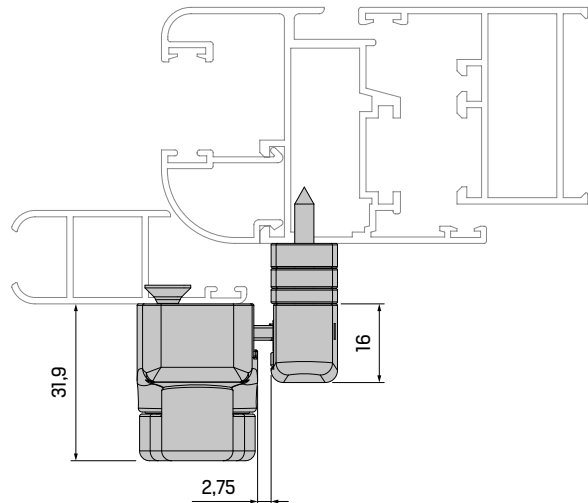



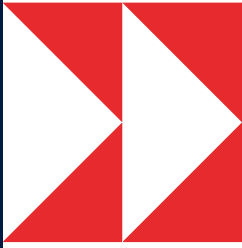

# 13

## **CORREDERA ELEVABLE** LIFT & SLIDE

- 253 **Especificaciones técnicas**  
Technical specifications
- 256 **Corredera elevable LS200**  
LS200 lift & slide
- 258 **Corredera elevable LS400**  
LS400 lift & slide
- 265 **Accesorios para correderas elevables**  
Lift & slide accessories



## Correderas **ELEVABLES** Lift & Slide



**Elevación equilibrada**  
Balanced elevation



**Esfuerzo reducido**  
Minimum effort



**Dispositivo de limpieza**  
Cleaning mechanism



**Amplio rango de cargas**  
Wide load range

El mercado del cerramiento arquitectónico demanda sistemas de corredera con menor sección visible de perfil que permitan mayor superficie de acristalamiento, mejora de las prestaciones en huecos de gran tamaño y fácil maniobrabilidad.

### » Corredera elevable LS200

El sistema de herraje elevable LS200 se presenta con el objetivo de dar una solución sólida y robusta a la creciente demanda del mercado del cerramiento. El sistema está diseñado de tal forma que permite un deslizamiento óptimo de las hojas de forma suave, silenciosa y sin esfuerzo.

El sistema LS200 posibilita la consecución de espacios diáfanos a través de las distintas aplicaciones de 2, 3, 4 y hasta 6 hojas con diferentes combinaciones de hojas fijas y correderas.

Por todo ello el sistema de herraje elevable STAC es la solución idónea para sistemas de corredera elevable con huecos de gran tamaño, siendo claves su gran maniobrabilidad, comodidad y sencillez de uso.

### » Corredera elevable LS400

El sistema LS400, especialmente diseñado para hojas de gran peso y dimensiones, que permite una elevación totalmente vertical de la corredera. Las hojas no cabecean en los movimientos de descenso y elevación.

Dentro de sus características cabe destacar el reparto de peso equitativo de la hoja sobre cada rueda durante toda la cinemática de elevación, garantizando el funcionamiento correcto de los rodamientos sin gripados, roturas ni aparición de ruidos.

The architectural enclosure market demands sliding systems with a smaller visible profile section that allows for a larger glazing surface, improved performance in large openings and easy manoeuvrability.

### » LS200 Lift & Slide

The LS200 lift & slide hardware system is presented with the aim of providing a solid and robust solution to the growing demand of the enclosure market. The system is designed in such a way as to allow the sashes to slide smoothly, quietly and effortlessly.

The LS200 system makes it possible to achieve open spaces through the different applications of 2, 3, 4 and up to 6 sashes with different combinations of fixed and sliding sashes.

For all these reasons, the STAC lift & slide hardware system is the ideal solution for lift & slide systems with large openings, with its great manoeuvrability, comfort and ease of use being key.

### » LS400 Lift & Slide

The LS400 system, specially designed for heavy and dimensional sashes, allows a totally vertical lifting of the slide. The sashes do not head in the lowering and lifting movements.

One of the most important features is the equal distribution of the weight of the sash on each wheel throughout the lifting mechanism, guaranteeing the correct operation of the bearings without seizure, breakage or noise.

» LS200

<b>Peso de la hoja</b> Sash weight	200 - 250 kg
<b>Altura de la hoja</b> Sash height	3300 mm
<b>Ancho de la hoja</b> Sash width	550 - 3300 mm
<b>Altura del canal</b> Height groove	30 mm
<b>Carros LS200_16</b> LS200_16 bogies	<b>Ranura de ancho 16 mm</b> 16 mm groove width
<b>Carros LS200_18</b> LS200_18 bogies	<b>Ranura de ancho 18 mm (con calzos de adaptación)</b> 18 mm groove width (with adaptative shims)
<b>Carros LS200_22</b> LS200_22 bogies	<b>Ranura de ancho 22 mm (con calzos de adaptación)</b> 22 mm groove width (with adaptative shims)
<b>Transmisión</b> Drive gear	<b>Aguja de 27,5 mm y distancia entre centros 80 mm</b> 27,5 mm backset and 80 mm fixing C/C distance

» LS400

<b>Peso de la hoja</b> Sash weight	300 - 400 kg
<b>Altura de la hoja</b> Sash height	3300 mm
<b>Ancho de la hoja</b> Sash width	550 - 3300 mm
<b>Altura del canal</b> Height groove	42 mm
<b>Carros LS400_22</b> LS400_22 bogies	<b>Ranura de ancho 22 mm</b> 22 mm groove width
<b>Transmisión</b> Drive gear	<b>Aguja de 37,5 mm y distancia entre centros 80 mm</b> 37,5 mm backset and 80 mm fixing C/C distance

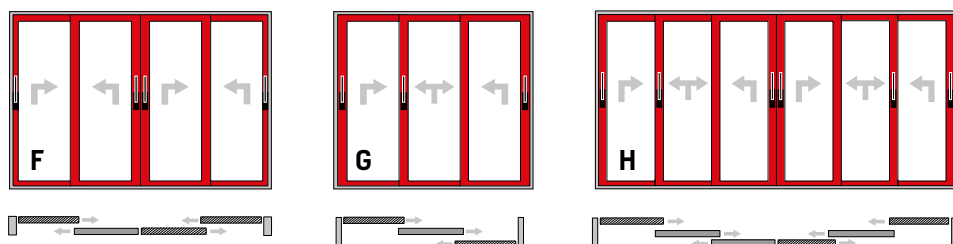
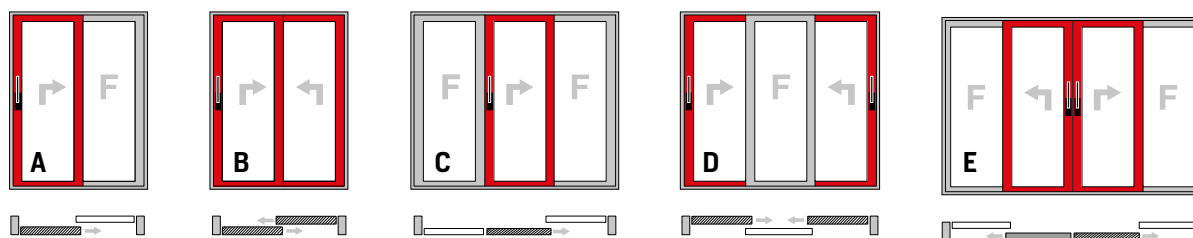

Z

- ▨ HOJA PRINCIPAL MAIN SASH
- HOJA INTERMEDIA INTERMEDIATE SASH
- HOJA FIJA FIXED SASH

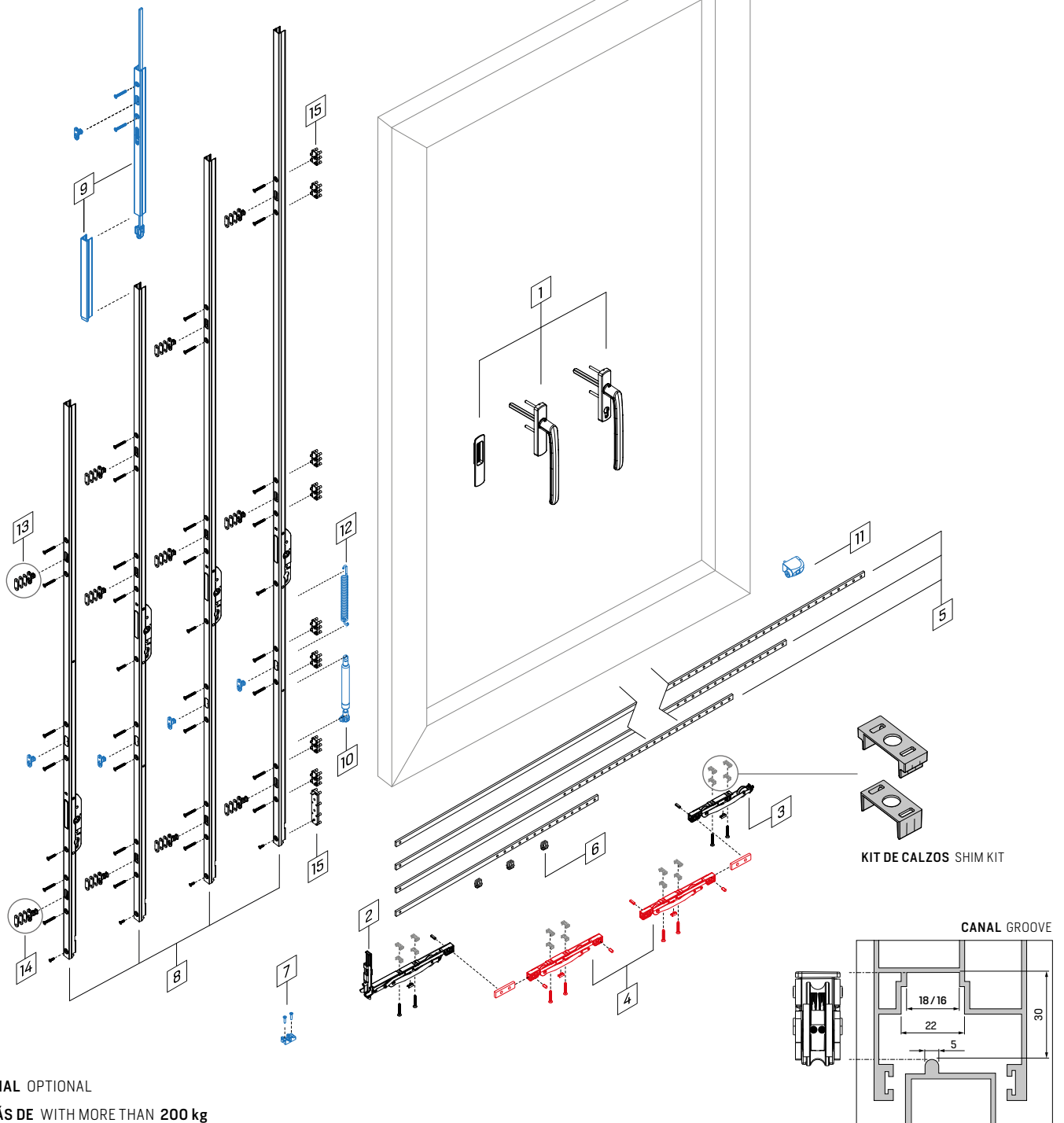

■ **OPCIONAL** OPTIONAL

■ **CON MÁS DE** WITH MORE THAN 200 kg

1	<b>Manillón ATRIA</b> ATRIA pull handle	<b>PAG. 86</b>
2	<b>Carro delantero</b> Front bogie	<b>233501</b>
3	<b>Carro trasero</b> Rear bogie	<b>233502</b>
4	<b>Carro suplementario</b> Supplementary bogie	<b>233503</b>
	<b>Pletina de conexión 2760 mm</b> 2760 mm connecting rod	<b>233010</b>
	<b>Pletina de conexión 1760 mm</b> 1760 mm connecting rod	<b>233011</b>
5	<b>Pletina de conexión 1260 mm</b> 1260 mm connecting rod	<b>233012</b>
	<b>Pletina de conexión 756 mm</b> 756 mm connecting rod	<b>233013</b>
6	<b>Centradores para pletina de conexión</b> Bottom guides for connecting rod	<b>237101</b>
7	<b>Cerradero horizontal</b> Horizontal keeper	<b>234322</b>

	<b>Falleba de transmisión accesible 1800 mm</b> 1800 mm accesible drive gear	<b>C234504</b>
	<b>Falleba de transmisión 2100 mm</b> 2100 mm drive gear	<b>C234501</b>
8	<b>Falleba de transmisión 2400 mm</b> 2400 mm drive gear	<b>C234502</b>
	<b>Falleba de transmisión 2700 mm</b> 2700 mm drive gear	<b>C234503</b>
	<b>Prolongador 500 mm sin punto de cierre</b> 500 mm extension rod without locking point	<b>234010</b>
9	<b>Prolongador 500 mm con punto de cierre</b> 500 mm extension rod with locking point	<b>A234011</b>
	<b>Cilindro amortiguador 150 - 250 kg</b> 150 - 250 kg damping cylinder	<b>237002</b>
10	<b>Cilindro amortiguador 251 - 400 kg</b> 251 - 400 kg damping cylinder	<b>237003</b>
	<b>Tope blanco</b> White stop	<b>234025</b>
11	<b>Tope negro</b> Black stop	<b>234026</b>

12	<b>Resorte de compensación</b> Compensating spring	<b>237001</b>
	<b>Punto de cierre + calzos</b> Locking point + shims	<b>A234020</b>
13	<b>Punto de cierre corto + calzos</b> Short locking point + shims	<b>234020</b>
	<b>Punto de cierre MV + calzos</b> MV locking point + shims	<b>A234021</b>
14	<b>Punto de cierre corto MV + calzos</b> MV short locking point + shims	<b>234021</b>
15	<b>Kit de calzos</b> Shim kit	<b>A2353</b>
-	<b>Kit de tornillería</b> Screw kit	<b>236007</b>
-	<b>Kit puntos de cierre cortos</b> Short locking points kit	<b>234301</b>
-	<b>Kit puntos de cierre</b> Locking points kit	<b>234302</b>
-	<b>Kit de hoja intermedia</b> Intermediate sash kit	<b>234303</b>

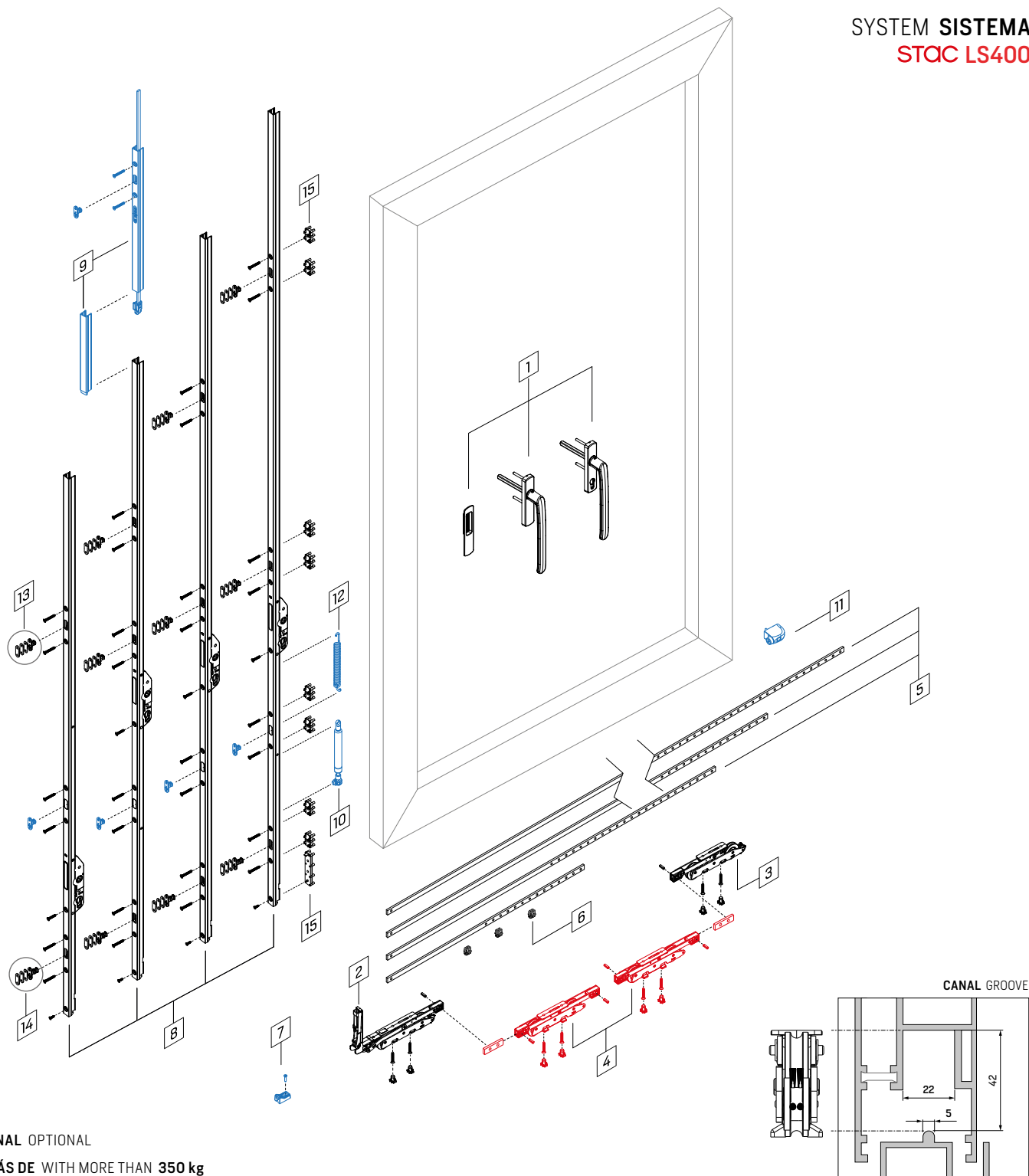

■ OPCIONAL OPTIONAL

■ CON MÁS DE WITH MORE THAN 350 kg

1	<b>Manillón ATRIA</b> ATRIA pull handle	PAG. 86
2	<b>Carro delantero</b> Front bogie	233001
3	<b>Carro trasero</b> Rear bogie	233002
4	<b>Carro suplementario</b> Supplementary bogie	233003
	<b>Pletina de conexión 2760 mm</b> 2760 mm connecting rod	233010
	<b>Pletina de conexión 1760 mm</b> 1760 mm connecting rod	233011
5	<b>Pletina de conexión 1260 mm</b> 1260 mm connecting rod	233012
	<b>Pletina de conexión 756 mm</b> 756 mm connecting rod	233013
6	<b>Centradores para pletina de conexión</b> Bottom guides for connecting rod	237101
7	<b>Cerradero horizontal</b> Horizontal keeper	234022

	<b>Falleba de transmisión accesible 1800 mm</b> 1800 mm accesible drive gear	C234004
	<b>Falleba de transmisión 2100 mm</b> 2100 mm drive gear	C234001
8	<b>Falleba de transmisión 2400 mm</b> 2400 mm drive gear	C234002
	<b>Falleba de transmisión 2700 mm</b> 2700 mm drive gear	C234003
	<b>Prolongador 500 mm sin punto de cierre</b> 500 mm extension rod without locking point	234010
9	<b>Prolongador 500 mm con punto de cierre</b> 500 mm extension rod with locking point	A234011
	<b>Cilindro amortiguador 150 - 250 kg</b> 150 - 250 kg damping cylinder	237002
10	<b>Cilindro amortiguador 251 - 400 kg</b> 251 - 400 kg damping cylinder	237003
	<b>Tope blanco</b> White stop	234025
11	<b>Tope negro</b> Black stop	234026

12	<b>Resorte de compensación</b> Compensating spring	237001
13	<b>Punto de cierre + calzos</b> Locking point + shims	A234020
14	<b>Punto de cierre MV + calzos</b> MV locking point + shims	A234021
15	<b>Kit de calzos</b> Shim kit	A2350
-	<b>Kit de tornillería</b> Screw kit	236004
-	<b>Kit puntos de cierre sin calzos</b> Locking points kit without shims	234101
-	<b>Kit puntos de cierre con calzos 15 mm</b> Locking points kit with 15 mm shims	234102
-	<b>Kit de hoja intermedia</b> Intermediate sash kit	234103

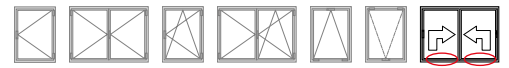

**CARRO DELANTERO LS200**  
LS200 FRONT BOGIE

233501



Carros LS200 para corredera elevable.

- Los carros soportan configuraciones de hasta 200 kg de hoja.
- Para configuraciones hasta 250 kg se han de añadir carros suplementarios.
- Disponibles calzos para adaptarse a diferentes tipos de canal.
- Las ruedas son de resina reforzada con el objetivo de soportar altas cargas.
- Fijación al perfil a través de tornillería con cabeza Pozidrive.
- Disponibles calzos con medidas de 1 y 2 mm para compensar la altura de hoja.

LS200 bogies for lift & slide.

- The bogies can support configurations of up to 200 kg of sash.
- For configurations up to 250 kg supplementary bogies must be added.
- Shims are available to adapt to different types of groove.
- The wheels are made of reinforced resin in order to support high loads.
- It is fixed to the profile by means of Pozidrive screws.
- Shims are available in 1 and 2 mm sizes to compensate the height of the sash.

**CARRO TRASERO LS200**  
LS200 REAR BOGIE

233502

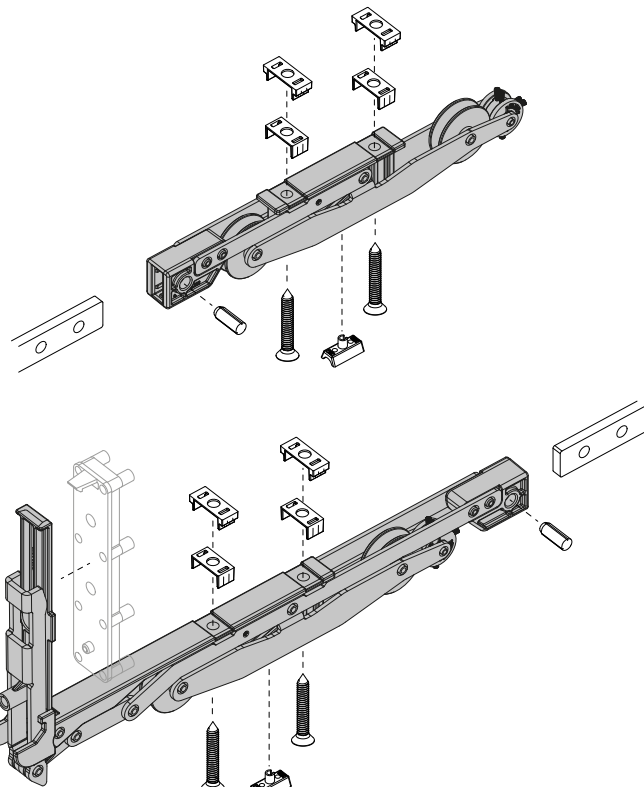

CONFIGURACIÓN CONFIGURATION ≤ 200 kg

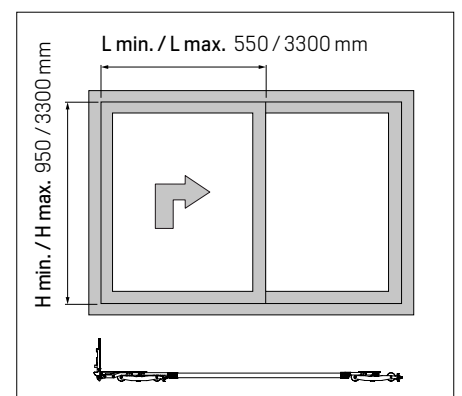

CALZOS SHIMS 1-2 mm

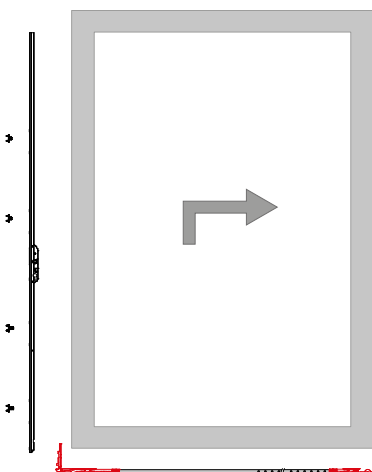
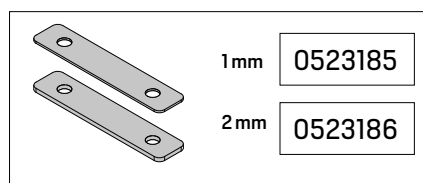

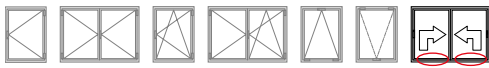

LS200 bogies for lift & slide.

- Shims are available in 1 and 2 mm sizes to compensate the height of the sash.

**Supplementary bogie**

- In configurations between 201 – 250 kg it is necessary to add two supplementary bogies per sash.
- It is fixed to the profile by means of Pozidrive screws.
- The supplementary bogies are supplied in an individual box with connection rods and screw kit.

**Fixed bogie**

- It allows the fixed sash to be placed at the same height as the mobile sash.

For large and heavy configurations, please contact us at [info@stac.es](mailto:info@stac.es)

Carros LS200 para corredera elevable.

- Disponibles calzos con medidas de 1 y 2 mm para compensar la altura de hoja.

**Carro suplementario**

- En configuraciones entre 201 – 250 kg es necesario añadir dos carros suplementarios por hoja.
- La fijación al perfil se realizará a través de tornillería con cabeza Pozidrive.
- Los carros suplementarios se sirven embalados en caja individual junto con pletinas de conexión y kit de tornillería.

**Carro fijo**

- Permite ubicar la hoja fija a la misma altura que la hoja móvil.

Para configuraciones de grandes dimensiones y pesos consúltenos en [info@stac.es](mailto:info@stac.es)

**CARRO SUPLEMENTARIO LS200**  
LS200 SUPPLEMENTARY BOGIE



233503



**CARRO FIJO LS200**  
LS200 FIXED BOGIE



233504

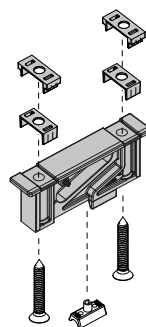
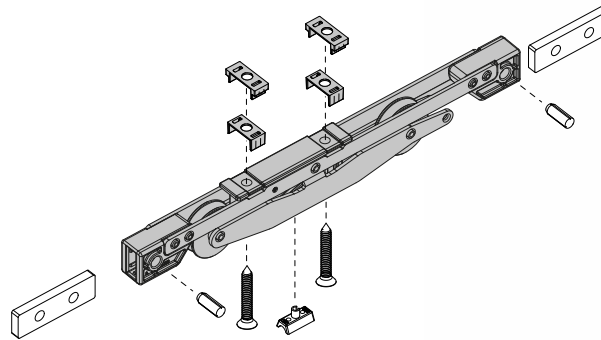
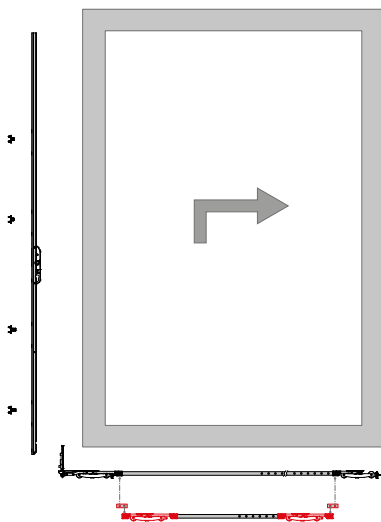

**CONFIGURACIÓN CONFIGURATION 201 – 250 kg**

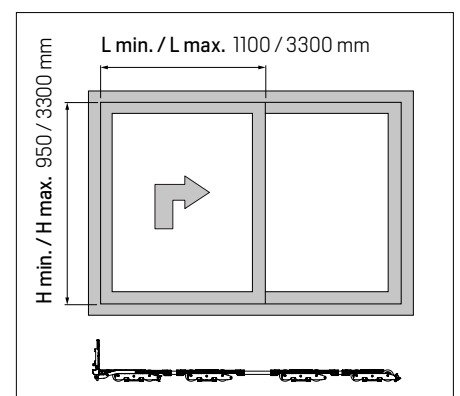

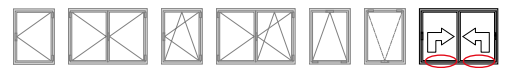

**CARRO DELANTERO LS400**  
LS400 FRONT BOGIE

233001



Carros LS400 para corredera elevable.

- Los carros soportan configuraciones de hasta 300 kg de hoja.
- Para configuraciones hasta 400 kg se han de añadir carros suplementarios.
- Las ruedas son de resina reforzada con el objetivo de soportar altas cargas.
- Sistema de limpieza rotacional sincronizada con el movimiento de las ruedas.
- Fijación al perfil a través de tornillería con cabeza Pozidrive.
- Disponible calzo de 1 mm para compensar la altura de hoja.

LS400 bogies for lift & slide.

- The bogies can support configurations of up to 300 kg of sash.
- For configurations up to 400 kg supplementary bogies must be added.
- The wheels are made of reinforced resin in order to support high loads.
- Rotational cleaning system synchronized with the movement of the wheels.
- It is fixed to the profile by means of Pozidrive screws.
- 1 mm shim available to compensate for the height of the sash.

**CARRO TRASERO LS400**  
LS400 REAR BOGIE

233002

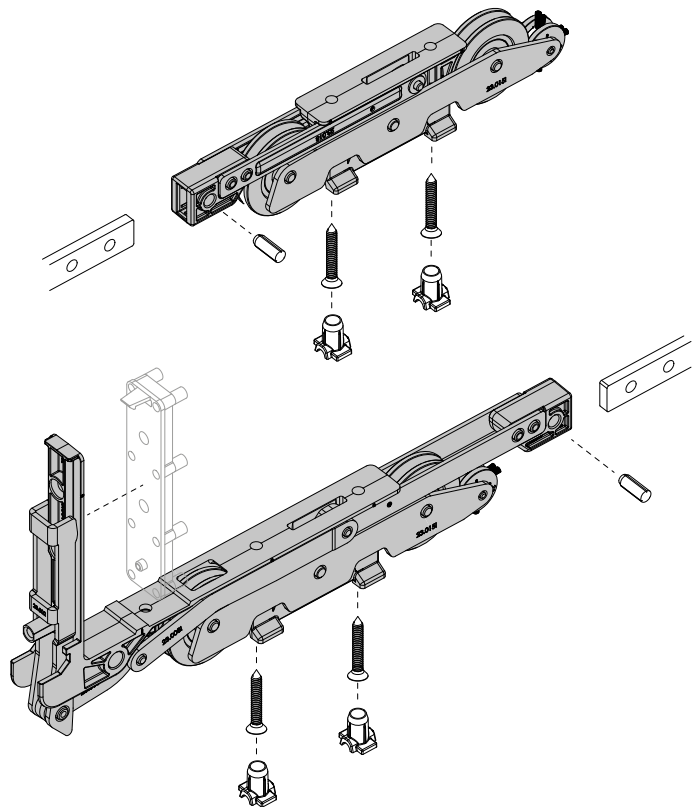

CONFIGURACIÓN CONFIGURATION ≤ 300 kg

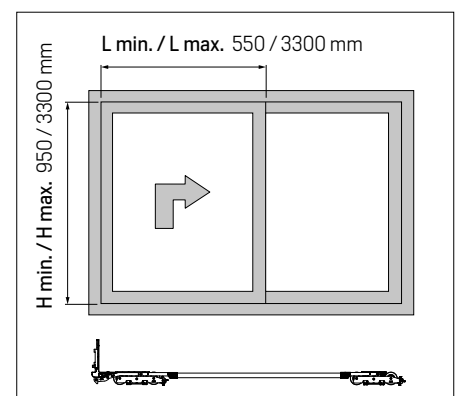

CALZO SHIM 2 mm

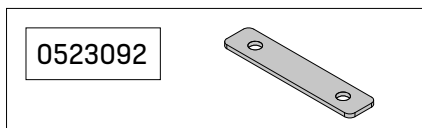
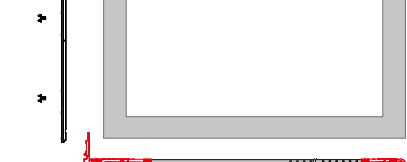



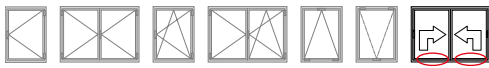

LS400 bogies for lift & slide.

- 1 mm shim available to compensate for the height of the sash.

**Supplementary bogie**

- In configurations between 301 – 400 kg it is necessary to add two supplementary bogies per sash.
- It is fixed to the profile by means of Pozidrive screws.
- The supplementary bogies are supplied in an individual box with connection rods and screw kit.

**Fixed bogie**

- It allows the fixed sash to be placed at the same height as the mobile sash.

For large and heavy configurations, please contact us at [info@stac.es](mailto:info@stac.es)

Carros LS400 para corredera elevable.

- Disponible calzo de 1 mm para compensar la altura de hoja.

**Carro suplementario**

- En configuraciones entre 301 – 400 kg es necesario añadir dos carros suplementarios por hoja.
- La fijación al perfil se realizará a través de tornillería con cabeza Pozidrive.
- Los carros suplementarios se sirven embalados en caja individual junto con pletinas de conexión y kit de tornillería.

**Carro fijo**

- Permite ubicar la hoja fija a la misma altura que la hoja móvil.

Para configuraciones de grandes dimensiones y pesos consúltenos en [info@stac.es](mailto:info@stac.es)

**CARRO SUPLEMENTARIO LS400**  
LS400 SUPPLEMENTARY BOGIE



233003



**CARRO FIJO LS400**  
LS400 FIXED BOGIE



233004

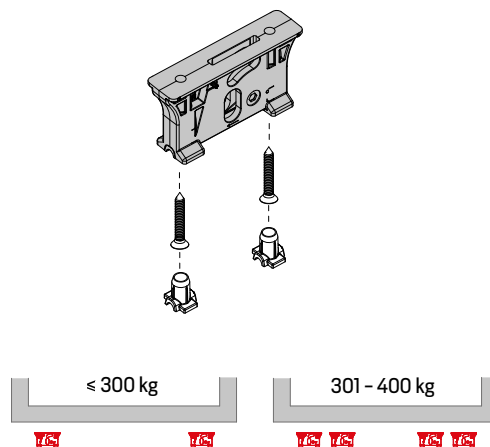
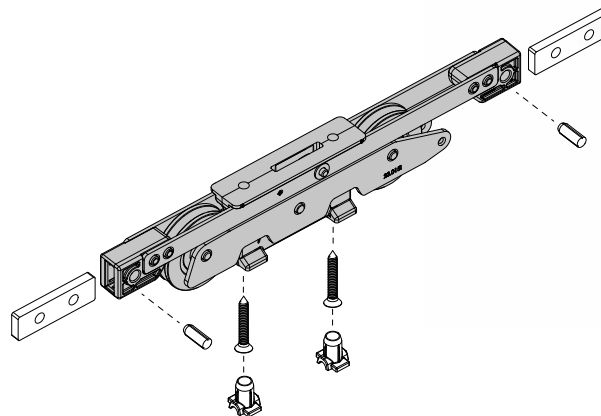
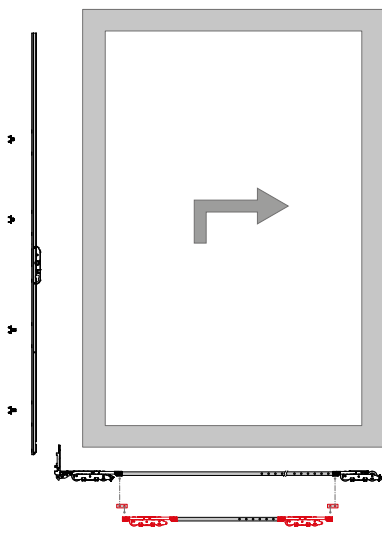

**CONFIGURACIÓN CONFIGURATION 301 – 400 kg**

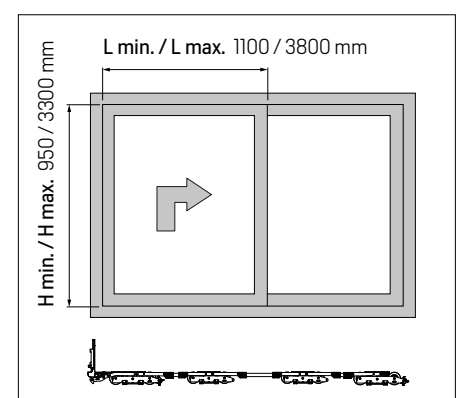

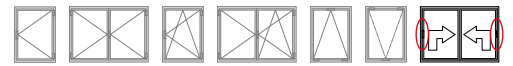

### FALLEBAS DE TRANSMISIÓN LS200

LS200 DRIVE GEARS

<b>C234501</b>	L = 2100 mm
<b>C234502</b>	L = 2400 mm
<b>C234503</b>	L = 2700 mm
<b>C234504</b>	L = 1800 mm



Fallebas de transmisión para el sistema de corredera elevable LS200.

- Disponibles con aguja de 27,5 mm.
- La distancia entre centros de fijación de las fallebas es de 80 mm.
- Las fallebas de transmisión se entregan con preinstalación para cilindro.
- La configuración básica consta de 3 puntos de cierre más 1 opcional.
- Disponible prolongador con un punto de cierre para configuraciones de alto de hoja mayores a 2800 mm.

Drive gears valid for the LS200 lift & slide door system.

- Available with 27.5 mm backset.
- The distance between fixing centres of the drive gears is 80 mm.
- The drive gears are delivered with cylinder pre-installation.
- The basic configuration consists of 3 locking points plus an optional one.
- Extension rod with locking point available for sash height configurations greater than 2800 mm.

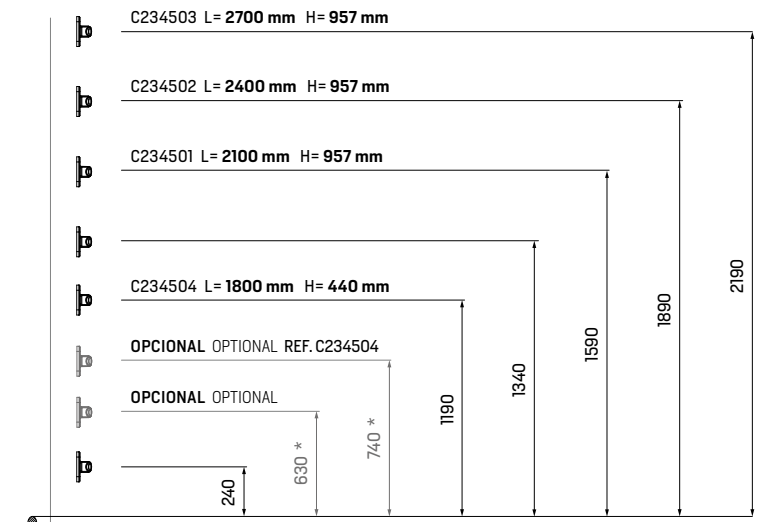
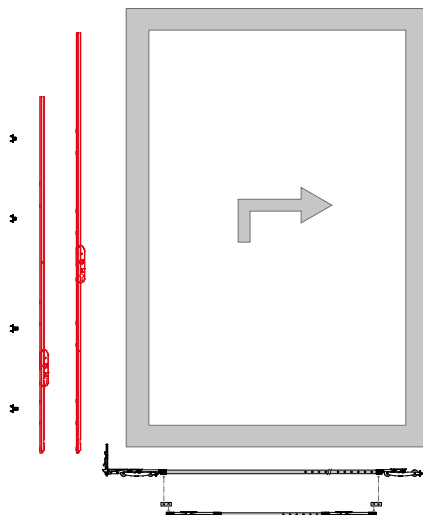
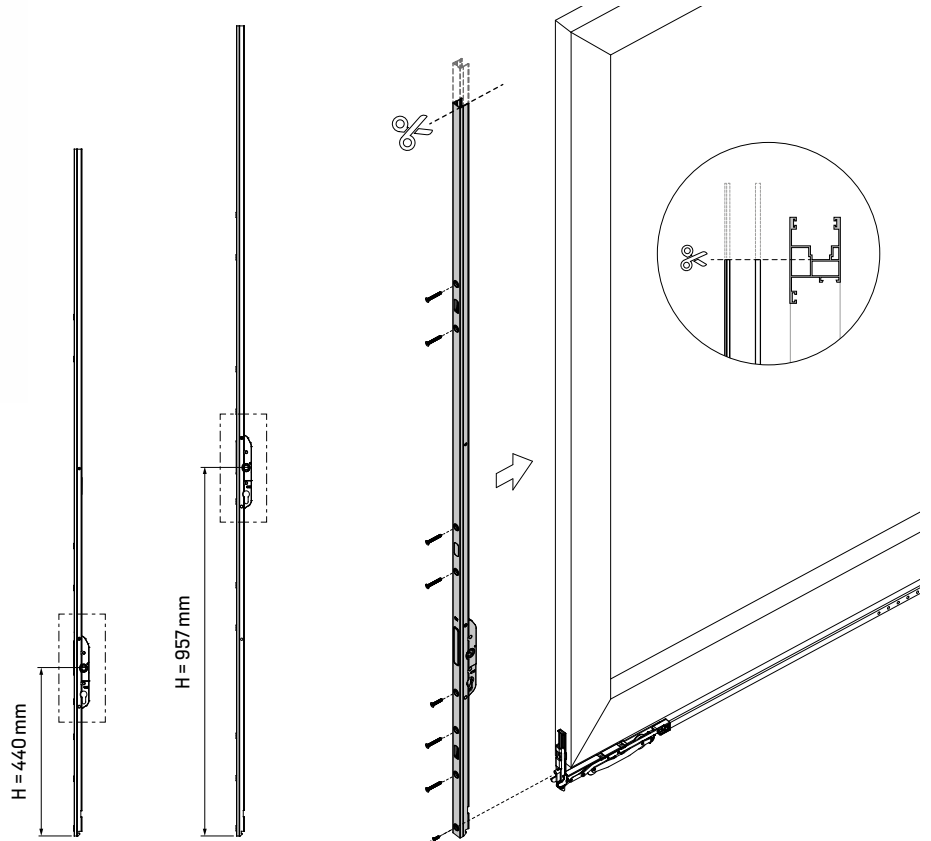
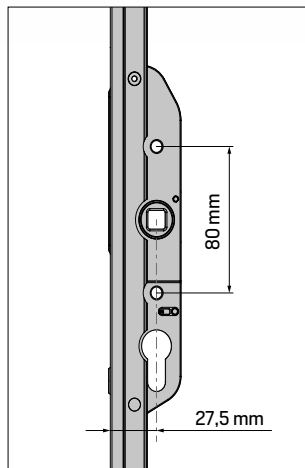

H = ALTURA DEL CUADRADILLO SPINDLE HEIGHT

L = ALTURA MÁXIMA DE LA FALLEBA DE TRANSMISIÓN DRIVE GEAR MAXIMUM HEIGHT

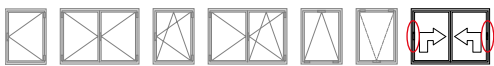

Drive gears valid for the LS400 lift & slide door system.

Fallebas de transmisión para el sistema de corredera elevable LS400.

- Available with 37.5 mm backset.
- The distance between fixing centres of the drive gears is 80 mm.
- The drive gears are delivered with cylinder pre-installation.
- The basic configuration consists of 3 locking points plus an optional one.
- Extension rod with locking point available for sash height configurations greater than 2800 mm.

- Disponibles con aguja de 37,5 mm.
- La distancia entre centros de fijación de las fallebas es de 80 mm.
- Las fallebas de transmisión se entregan con preinstalación para cilindro.
- La configuración básica consta de 3 puntos de cierre más 1 opcional.
- Disponible prolongador con un punto de cierre para configuraciones de alto de hoja mayores a 2800 mm.

**FALLEBAS DE TRANSMISIÓN LS400**  
LS400 DRIVE GEARS



L = 2100 mm **C234001**

L = 2400 mm **C234002**

L = 2700 mm **C234003**

L = 1800 mm **C234004**

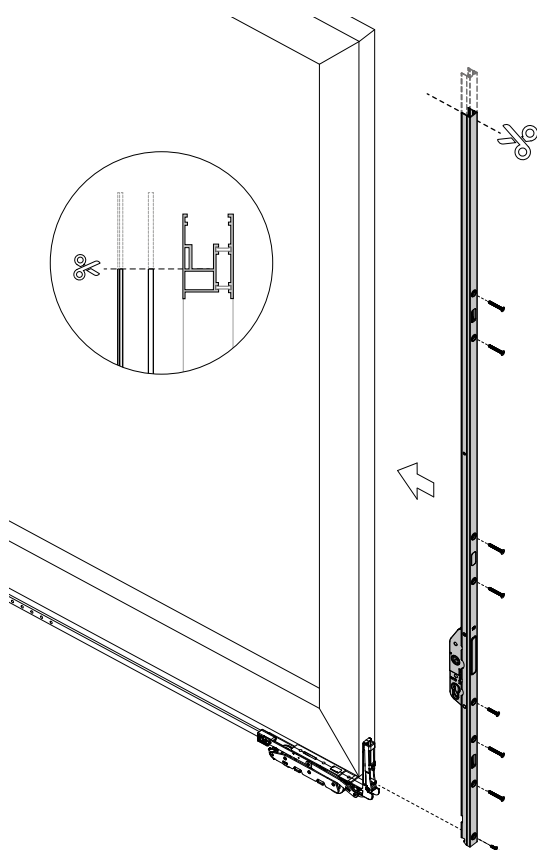

H = 440 mm

H = 957 mm

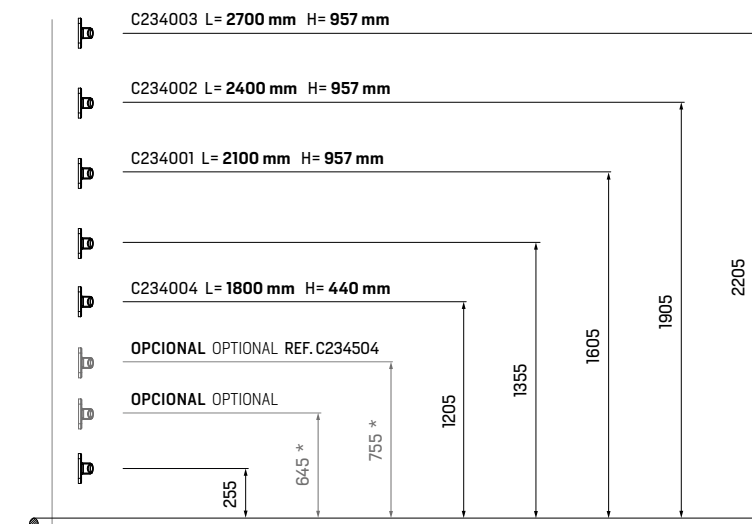
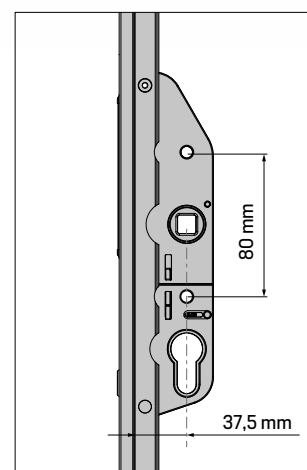

H = ALTURA DEL CUADRADILLO SPINDLE HEIGHT

L = ALTURA MÁXIMA DE LA FALLEBA DE TRANSMISIÓN DRIVE GEAR MAXIMUM HEIGHT

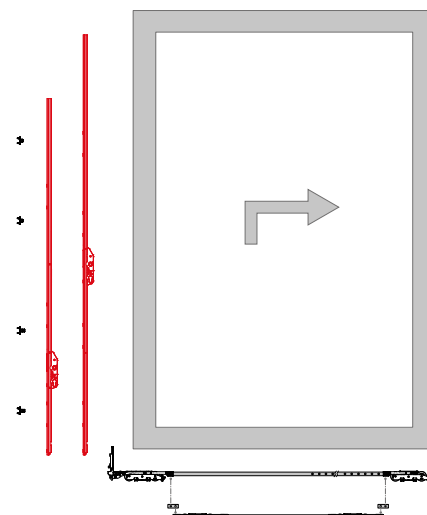

## CALZOS PARA FALLEBAS DE TRANSMISIÓN LS200

LS200 DRIVE GEAR SHIMS

### KITS DE CALZOS PARA ELEVABLE LS200

LS200 LIFT & SLIDE SHIMS



Calzos plásticos LS200 para fallestas de transmisión y carros delanteros.

- Los calzos de poliamida PA6 + 25% de fibra de vidrio permiten la conservación de la rotura del puente térmico.
- Los calzos plásticos permiten una fabricación más ecológica y una reducción de peso considerable en comparación con los calzos metálicos.

LS200 plastic shims for drive gears and lift & slide front bogies.

- The PA6 polyamide + 25% fibreglass shims allow the thermal break to be maintained.
- Plastic shims allow for more environmentally friendly manufacturing and a considerable weight reduction compared to metal shims.

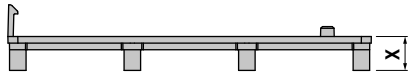
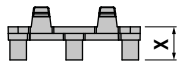

REF.	ANCHO WIDTH (X)	REF.	ANCHO WIDTH (X)
A235309	4 mm	A235307	14 mm
A235310	5 mm	A235301	16 mm
A235308	6 mm	A235306	17 mm
A235311	7 mm	A235303	17,5 mm
A235312	8 mm	A235302	19 mm
A235313	9 mm	A235304	20 mm
A235314	10 mm	A235305	23 mm
A235315	12 mm		

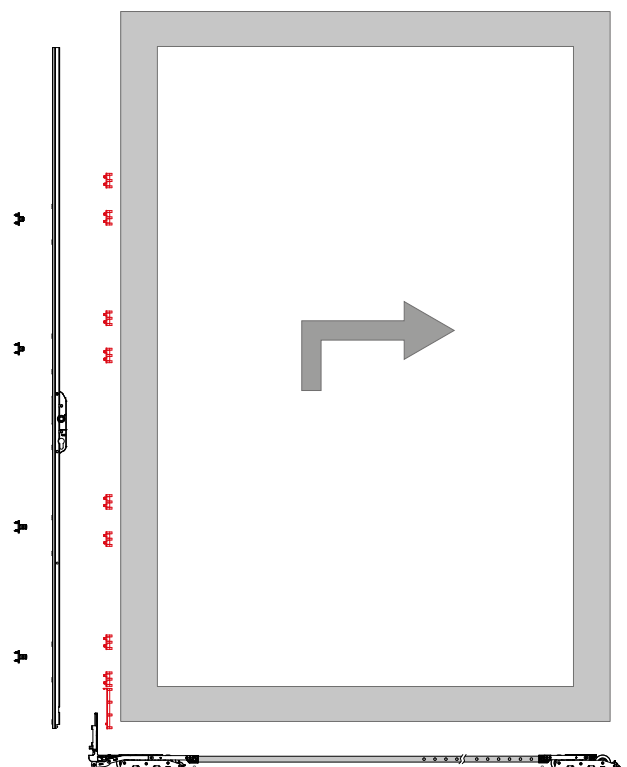

LS400 plastic shims for drive gears and lift & slide front bogies.

- The PA6 polyamide + 25% fibreglass shims allow the thermal break to be maintained.
- Plastic shims allow for more environmentally friendly manufacturing and a considerable weight reduction compared to metal shims.

Calzos plásticos LS400 para fallestas de transmisión y carros delanteros.

- Los calzos de poliamida PA6 + 25% de fibra de vidrio permiten la conservación de la rotura del puente térmico.
- Los calzos plásticos permiten una fabricación más ecológica y una reducción de peso considerable en comparación con los calzos metálicos.

### KITS DE CALZOS PARA ELEVABLE LS400

LS400 LIFT & SLIDE SHIMS

PA



A2352

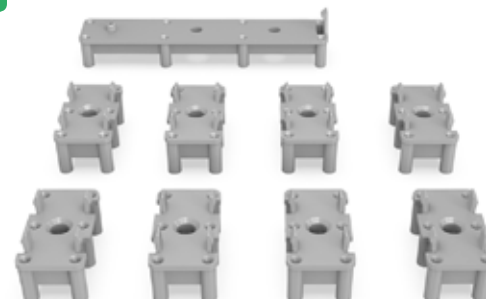

REF. ANCHO WIDTH (X)

A235207	12 mm
A235201	14 mm
A235206	15 mm
A235203	15,5 mm
A235202	17 mm
A235204	18 mm
A235205	21 mm

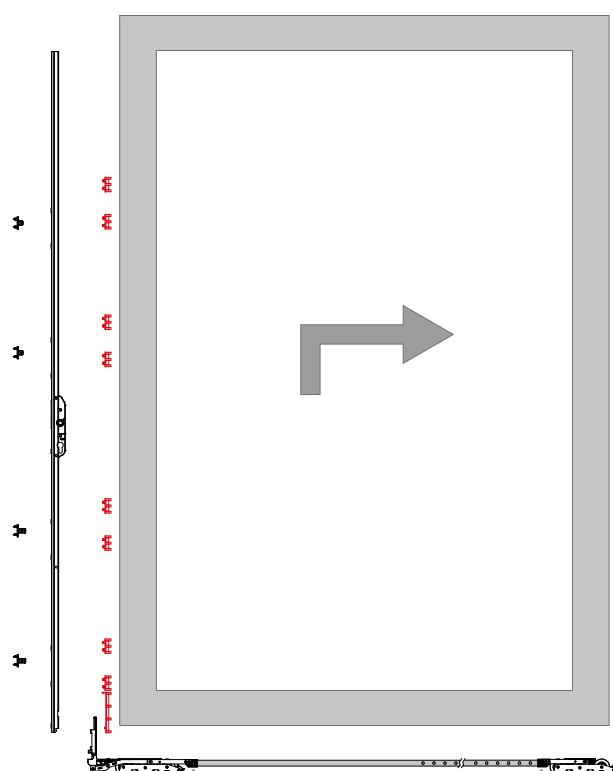
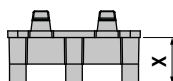

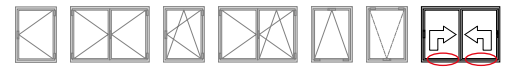

**PLETINAS DE CONEXIÓN**  
CONNECTING ROD

233010	L = 2760 mm
233011	L = 1760 mm
233012	L = 1260 mm
233013	L = 756 mm



Pletinas de conexión en acero para sistemas de corredera elevable.

Steel connecting rods for lift & slide door systems.

- Pletinas adaptables a un amplio rango de ancho de hoja gracias al multiperforado del que disponen.
- La fijación de las pletinas a los carros se realiza mediante bulones de acero.
- Resistencia a la corrosión de acuerdo con la norma UNE-EN 1670: 240 horas en cámara de niebla salina.

- The multi-perforated connecting rods can be adapted to a wide range of sash widths.
- The plates are fixed to the bogies by means of steel bolts.
- Corrosion resistance in accordance with the UNE-EN 1670 standard: 240 hours in a saline mist chamber.



**■ CONFIGURACIÓN ESTÁNDAR**  
STANDARD CONFIGURATION

**■ CONFIGURACIÓN CON 2 CARROS SUPLEMENTARIOS**  
STANDARD CONFIGURATION WITH 2 SUPPLEMENTARY BOGIES

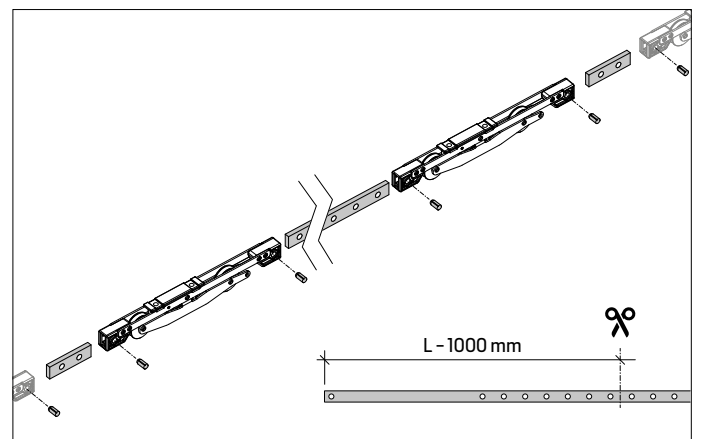
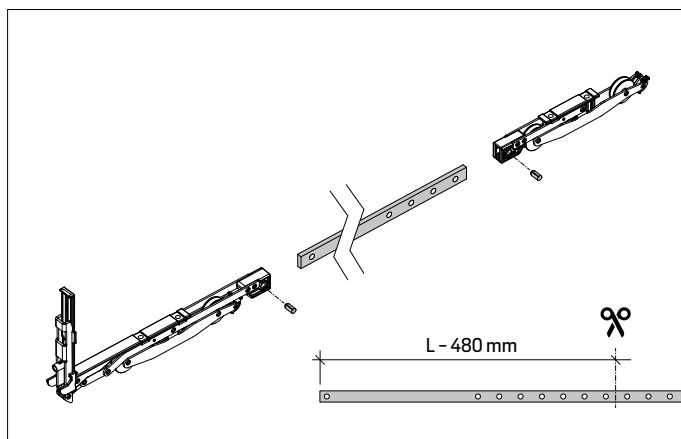

REFERENCIA REFERENCE	LONGITUD LENGTH	CONFIG. ESTÁNDAR STANDARD CONFIG.	CON CARROS SUPLEMENTARIOS WITH SUPPLEMENTARY BOGIES	CENTRADORES BOTTOM GUIDES
233010	2760 mm	2301 - 3300 mm	2801 - 3800 mm	6
233011	1760 mm	1801 - 2300 mm	2301 - 2800 mm	3
233012	1260 mm	1301 - 1800 mm	1301 - 2300 mm	2
233013	756 mm	600 - 1300 mm	1100 - 1800 mm	1



0423071

Se incluyen 3 centradores para la pletina de conexión en los kits de cerraderos: 234101, 234102, 234103, 234301, 234302 y 234303.

3 bottom guides for the connecting rod are included in the locking point kits: 234101, 234102, 234103, 234301, 234302 and 234303.



Extension rods for the drive gears of lift & slide door systems.

**Extension rod with locking point**

- The A234011 extension rod provides an additional locking point in window configurations with heights of more than 2800 mm and sash heights of up to 3300 mm.
- The extension rod is fixed by means of a set screw.
- The extension rod is fixed to the profile by means of Pozidrive screws.
- Zinc-plated steel parts to guarantee 240 hours of corrosion resistance in a saline mist chamber in accordance with the UNE-EN 1670 standard.

**Extension rod without locking point**

- The 234010 extension rod is valid for window configurations with heights above 2800 mm that do not require an additional locking point.
- The 234010 extension rod can be added between the drive gear and the extension rod with locking point.
- It is available in natural matt anodised finish.

Prolongadores para fallebas de transmisión de correderas elevables.

**Prolongador con punto de cierre**

- El prolongador A234011 aporta un punto de cierre adicional en configuraciones de ventana con alturas superiores a 2800 mm pudiendo alcanzar alturas de hoja de hasta 3300 mm.
- La fijación del prolongador se realiza a través de tornillo prisionero.
- La fijación al perfil se realiza a través de tornillería con cabeza Pozidrive.
- Piezas en acero zincadas para garantizar una resistencia a la corrosión de 240 horas en cámara de niebla salina de acuerdo con la norma UNE-EN 1670.

**Prolongador sin punto de cierre**

- El prolongador 234010 es válido para configuraciones de ventana con alturas superiores a 2800 mm que no necesitan de un punto de cierre adicional.
- El prolongador 234010 se puede añadir entre la falleba de transmisión y el prolongador con punto de cierre.
- Está disponible en acabado anodizado natural mate.

**PROLONGADOR CON PUNTO DE CIERRE**

EXTENSION ROD WITH LOCKING POINT



**A234011**



**PROLONGADOR SIN PUNTO DE CIERRE**

EXTENSION ROD WITHOUT LOCKING POINT



**234010**

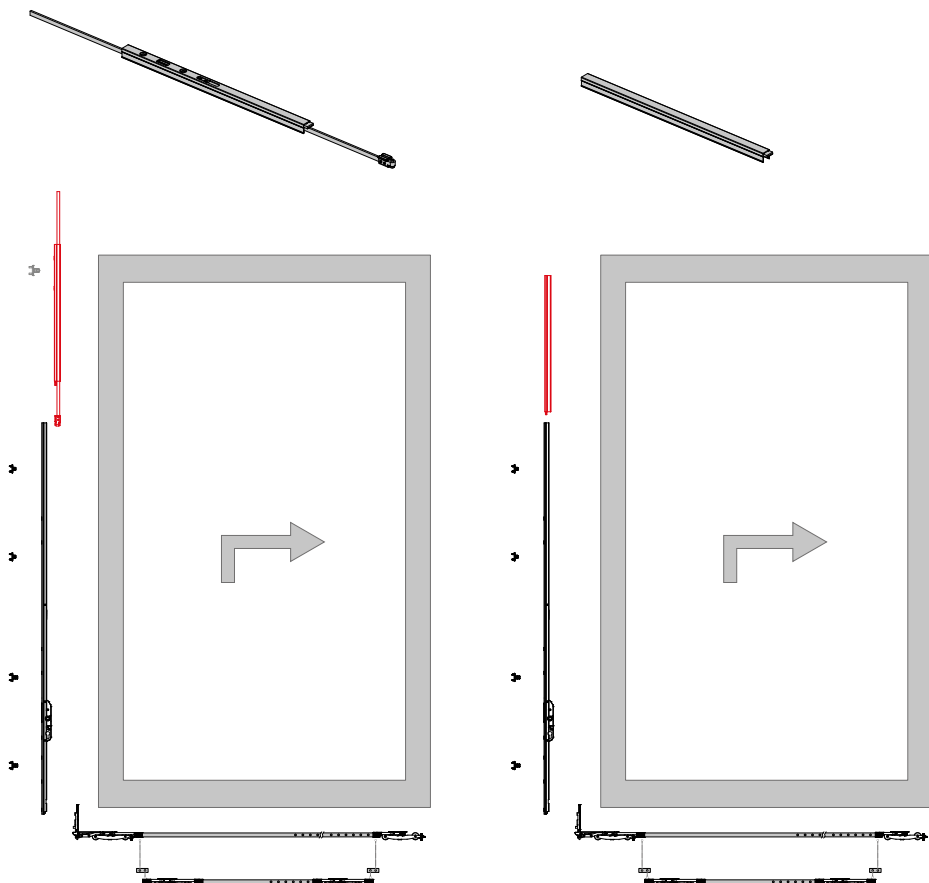

**INSTRUCCIONES DE MONTAJE**  
ASSEMBLY INSTRUCTIONS

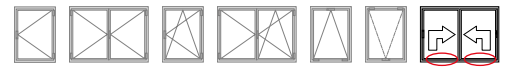

**CERRADERO LS200**  
LS200 KEEPER

234322

50



ZM



Cerraderos horizontales para sistemas de corredera elevable.

- Los cerraderos se fijan al perfil a través de tornillería con cabeza Pozidrive.
- Los cerraderos se sirven embolsados con la tornillería.
- Las piezas se han zincado para garantizar una resistencia a la corrosión de 240 horas en cámara de niebla salina de acuerdo con la norma UNE-EN 1670.

**Cerradero 234022**

- Dispone de un mecanismo de retención lateral regulable para hoja intermedia.

Horizontal keepers for lift & slide door systems.

- The keepers are fixed to the profile by means of Pozidrive screws.
- The keepers are supplied in bags with the screws.
- The parts have been zinc-plated to guarantee a corrosion resistance of 240 hours in a saline mist chamber in accordance with the UNE-EN 1670 standard.

**Keeper 234022**

- It has an adjustable side retention mechanism for the intermediate sash.

**CERRADERO LS400**  
LS400 KEEPER

234022

100



ZM

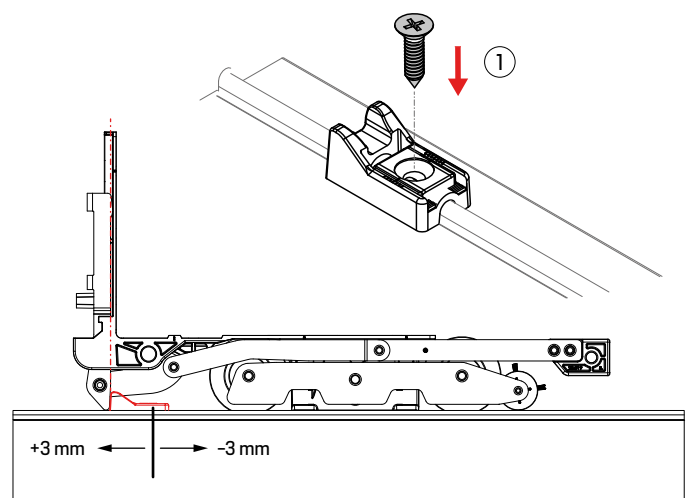
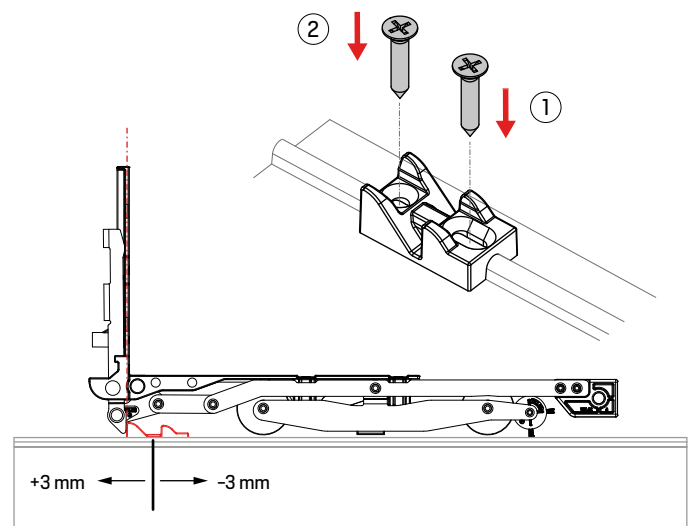



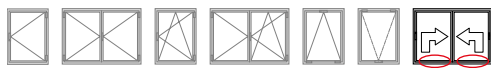

## TOPES DE AMORTIGUACIÓN Y KITS DE TORNILLERÍA

### DAMPING STOPS AND SCREW KITS

Highly resistant rubber stops to cushion the impact of the sash.

- It is fixed to the profile by means of a screw and an anti-rotation pin.
- For every two sashes a damping stop must be installed.
- The damping stops are supplied in bags and with the screws.

Topes de goma de alta resistencia con el fin de amortiguar el impacto de la hoja.

- La fijación al perfil se realiza mediante un tornillo y un bulón anti giro.
- Por cada 2 hojas es necesario instalar un tope de amortiguación.
- Los topes de amortiguación se sirven embolsados y con la tornillería.

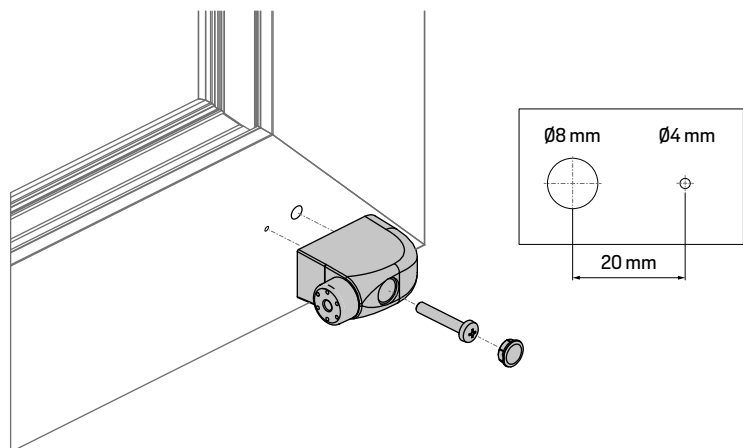

## TOPE DE AMORTIGUACIÓN

### DAMPING STOP



**Acabado blanco**  
White finish

234025

**Acabado negro**  
Black finish

234026



## KITS DE TORNILLERÍA

### SCREW KITS



23600



## KITS DE TORNILLERÍA SCREW KITS

REF.	LS200	LS400	4,8 x 19 mm	4,8 x 32 mm	4,8 x 38 mm	4,8 x 50 mm	4,8 x 55 mm	4,8 x 60 mm	
236004 *		●	1 unidad / unit	12 unidades / units	-	8 unidades / units	-	-	100
236005 *		●	1 unidad / unit	12 unidades / units	-	-	-	8 unidades / units	250
236007	●		7 unidades / units	-	12 unidades / units	-	-	-	100
236008	●		-	7 unidades / units	4 unidades / units	8 unidades / units	-	-	100
236010		●	1 unidad / unit	12 unidades / units	-	-	8 unidades / units	-	100

\* 236004 PARA CALZOS FOR SHIMS ≤ 18 mm

\* 236005 PARA CALZOS FOR SHIMS > 18 mm

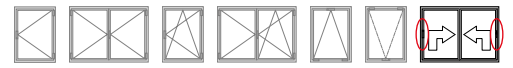

**CILINDRO DE AMORTIGUACIÓN SOFT-LIFT**

SOFT-LIFT DAMPING CYLINDER

23700

Ver tabla de referencias  
See table of references



**RESORTE DE COMPENSACIÓN**

COMPENSATION SPRING

237001



Sistemas de amortiguación y compensación para correderas elevables.

Damping and compensation systems for lift & slide doors.

**SOFT-LIFT**

- El sistema SOFT-LIFT permite trasladar la manilla a la posición de cierre de una manera suave e intuitiva.
- El sistema permite una amortiguación suave y precisa de la hoja en el movimiento de descenso.
- Evita golpes bruscos de la manilla y aumenta considerablemente la durabilidad del mecanismo de elevación.
- El sistema es compatible con cualquier medida de falleba de transmisión.

**SOFT-LIFT**

- The SOFT-LIFT system allows the handle to be moved to the closing position in a smooth and intuitive way.
- The system allows a smooth and precise damping of the sash in the lowering movement.
- It avoids sudden impacts of the handle and considerably increases the durability of the lifting mechanism.
- The system is compatible with any size of drive gear.



**Resorte de compensación**

- El resorte permite compensar el peso reduciendo el esfuerzo de elevación de la hoja.
- Minimiza el par de retorno del manillón en la bajada de la hoja.
- Se recomienda su instalación para pesos de hoja a partir de 200 kg.
- Muelle en acero zincadas para garantizar una resistencia a la corrosión de 240 horas en cámara de niebla salina de acuerdo con la norma UNE-EN 1670.

**Compensation spring**

- The spring allows the weight to be compensated by reducing the sash's lifting force.
- Minimises the return torque of the door handle when lowering the sash.
- Recommended for sash weights of 200 kg and above.
- Zinc-plated steel spring to guarantee 240 hours of corrosion resistance in a saline mist chamber in accordance with the UNE-EN 1670 standard.

» **SOFT-LIFT**

REFERENCIA REFERENCE	PESO POR HOJA WEIGHT PER SASH			FALLEBA DE TRANSMISIÓN DRIVE GEAR
237002	150 - 250 kg	●		2100 mm 2400 mm
237003	251 - 400 kg		●	2700 mm
237004	150 - 250 kg	●		1800 mm
237005	251 - 400 kg		●	

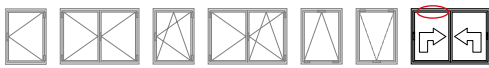

Anti-trapping system that allows for the damping braking of the sash.

- The system allows for damping braking of the sash regardless of the force applied to it.
- It includes adaptation shims for different profile series.
- The system is compatible with aluminium, wood and PVC profiles.
- The mechanism has been specially designed for public areas or areas with children.
- Maximum sash weight allowed 300 kg.
- Position adjustment of 8 mm.

Sistema antiatrapamiento que permite el frenado amortiguado de la hoja.

- El sistema permite un frenado amortiguado de la hoja independientemente de la fuerza con la que se actúe.
- Incluye calzos de adaptación para diferentes series de perfil.
- El sistema es compatible con perfiles de aluminio, madera y PVC.
- El mecanismo ha sido especialmente concebido para zonas de pública concurrencia o con niños.
- Peso máx. de hoja permitido de 300 kg.
- Regulación de posición de 8 mm.

**SISTEMA SOFT-CLOSING**  
SOFT-CLOSING SYSTEM



237007



**REGULACIÓN** ADJUSTMENT

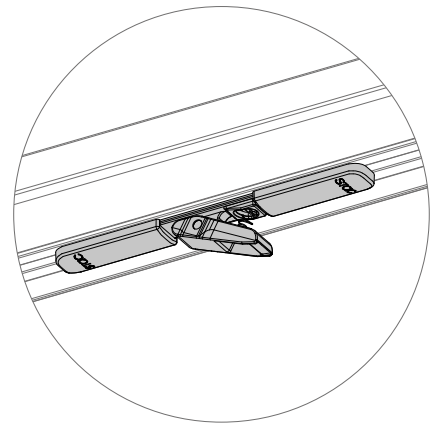
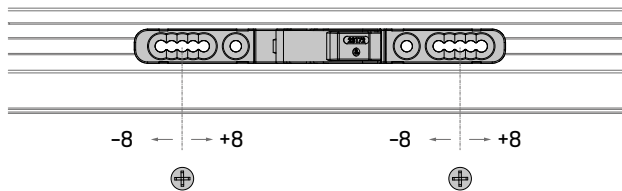

**MARCO** FRAME

**HOJA** SASH

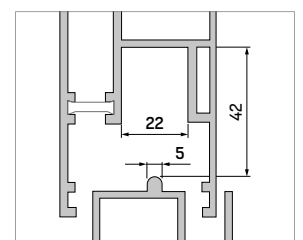
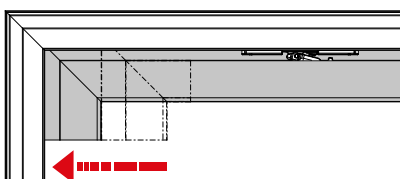
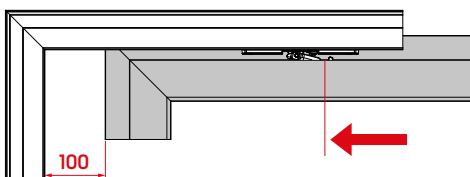
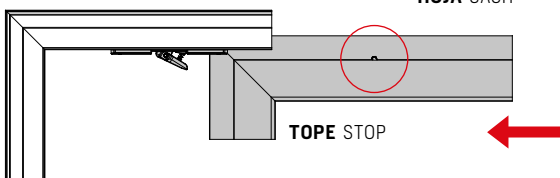

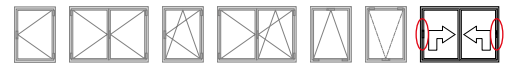

**PUNTO DE CIERRE + CALZOS**  
LOCKING POINT + SHIMS

**234320** Cierre corto Short locking

**A234020** Cierre largo Large locking

10

INX PA

Is200

Is400

Puntos de cierre de acero inoxidable con calzos plásticos fabricados en poliamida PA6 + 10% de fibra de vidrio.

Stainless steel locking points with plastic shims made of polyamide PA6 + 10% fibreglass.

- Reducción de peso y fabricación más ecológica frente a los calzos metálicos.

- Weight reduction and more ecological manufacture compared to metal shims.

**PUNTO DE CIERRE MV + CALZOS**  
MICRO-VENTILATION LOCKING POINT + SHIMS

**234321** Cierre corto Short locking

**A234021** Cierre largo Large locking

10

INX PA

Is200

Is400

MV

REF.	DIMENSIONES	DIMENSIONS	KIT 234203
234320			•
A234020			•
234321			•
A234021			•
234203			

**KIT DE CALZOS**  
SHIMS KIT

**234203** Calzos de 1, 2 y 3 mm Shims of 1, 2 and 3 mm

25

PA

Is200

Is400

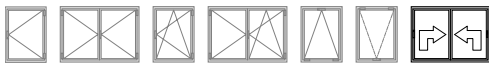

Single-sash kits consisting of locking points and shims for LS200 lift & slide.

- Single-sash kits available with 9 and 15 mm zamak shims.
- Single-sash kits available with 1, 2 and 3 mm polyamide shims.

Kits de una hoja compuestos por puntos de cierre y calzos para elevable LS200.

- Disponibles kits de una hoja con calzos de zamak de 9 y 15 mm.
- Disponibles kits de una hoja con calzos de poliamida de 1, 2 y 3 mm.

**KIT PUNTOS DE CIERRE CORTOS CON CALZOS**  
SHORT LOCKING POINTS KIT WITH SHIMS



**KIT PUNTOS DE CIERRE LARGOS CON CALZOS**  
LONG LOCKING POINTS KIT WITH SHIMS



**KIT PUNTOS DE CIERRE LARGOS CON CALZOS**  
LONG LOCKING POINTS KIT WITH SHIMS

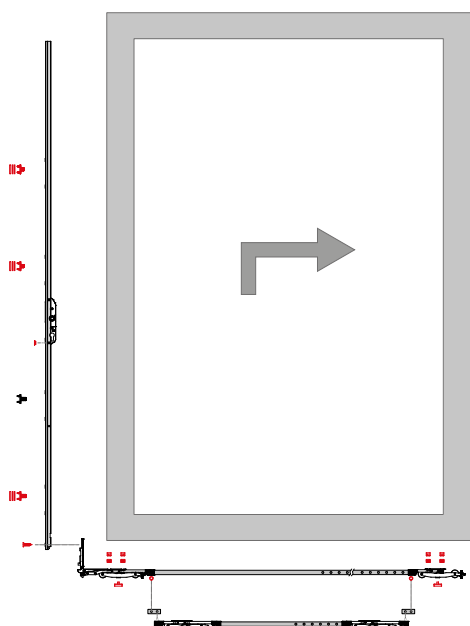

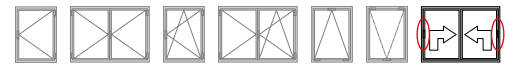

**PUNTO DE CIERRE LARGO + CALZO**  
LONG LOCKING POINT + SHIM

**234023** Calzo de zamak 15 mm  
15 mm zamak shim

**234033** Calzo de zamak 9 mm  
9 mm zamak shim

INX ZM

Is200

Is400

**PUNTO DE CIERRE CORTO + CALZO**  
SHORT LOCKING POINT + SHIM

**234037** Calzo de zamak 15 mm  
15 mm zamak shim

**234035** Calzo de zamak 9 mm  
9 mm zamak shim

INX ZM

Is200

Is400

**PUNTO DE CIERRE LARGO MV + CALZO**  
MICRO-VENTILATION LONG LOCKING POINT + SHIM

**234024** Calzo de zamak 15 mm  
15 mm zamak shim

**234034** Calzo de zamak 9 mm  
9 mm zamak shim

INX ZM

Is200

Is400

MV

**PUNTO DE CIERRE CORTO MV + CALZO**  
MICRO-VENTILATION SHORT LOCKING POINT + SHIM

**234038** Calzo de zamak 15 mm  
15 mm zamak shim

**234036** Calzo de zamak 9 mm  
9 mm zamak shim

INX ZM

Is200

Is400

MV

Puntos de cierre de acero inoxidable con calzo de zamak de 9 o 15 mm para series de perfil de corte recto.

- La fijación al perfil se realiza a través de tornillería con cabeza Pozidrive.
- Calzo zincado para garantizar una resistencia a la corrosión de 240 horas en cámara de niebla salina de acuerdo con la norma UNE-EN 1670.

Stainless steel locking points with 9 or 15 mm zamak shim for straight cut profile series.

- Fixing to the profile is done by means of Pozidrive screws.
- Zinc-plated shim to guarantee 240 hours of corrosion resistance in a saline mist chamber in accordance with the UNE-EN 1670 standard.

REF.	DIMENSIONES	DIMENSIONS	9 mm	15 mm
234023				•
234033			•	
234037				•
234035			•	
234024				•
234034			•	
234038				•
234036			•	

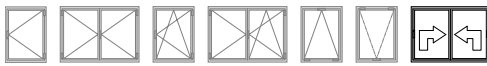

Single-sash kits consisting of locking points and shims for LS400 lift & slide.

- Single-sash kits available with 9 and 15 mm zamak shims.
- Single-sash kits available with 1, 2 and 3 mm polyamide shims.

Kits de una hoja compuestos por puntos de cierre y calzos para elevable LS400.

- Disponibles kits de una hoja con calzos de zamak de 9 y 15 mm.
- Disponibles kits de una hoja con calzos de poliamida de 1, 2 y 3 mm.

**KIT PUNTOS DE CIERRE LARGOS SIN CALZOS**  
LONG LOCKING POINTS KIT WITHOUT SHIMS



234101

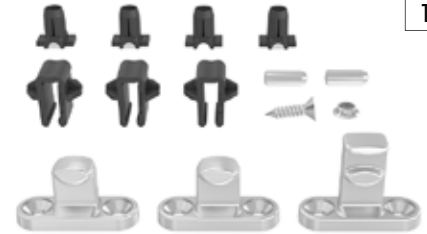

**KIT PUNTOS DE CIERRE LARGOS CON CALZOS**  
LONG LOCKING POINTS KIT WITH SHIMS



Calzos de zamak 15 mm  
15 mm zamak shims

234102

Calzos de zamak 9 mm  
9 mm zamak shims

234109



**KIT PUNTOS DE CIERRE LARGOS CON CALZOS**  
LONG LOCKING POINTS KIT WITH SHIMS



Calzos de poliamida  
Polyamide shims

234108

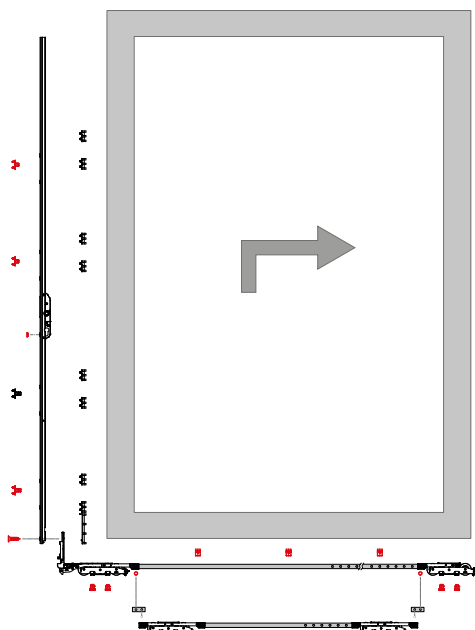
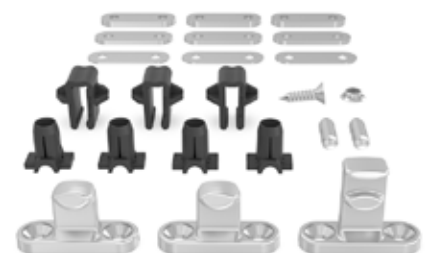

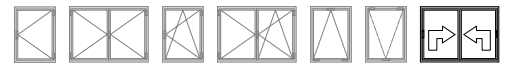

**KIT DE HOJA INTERMEDIA LS200**  
LS200 INTERMEDIATE SASH KIT

234303



50



Kits específicos para hojas intermedias que no necesitan puntos de cierre.

Specific kits for intermediate sashes that do not require locking points.

- Disponibles kits de hoja para sistemas elevables LS200 y LS400.

- Sash kits are available for LS200 and LS400 lift & slide systems.

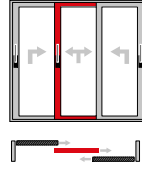

LS200

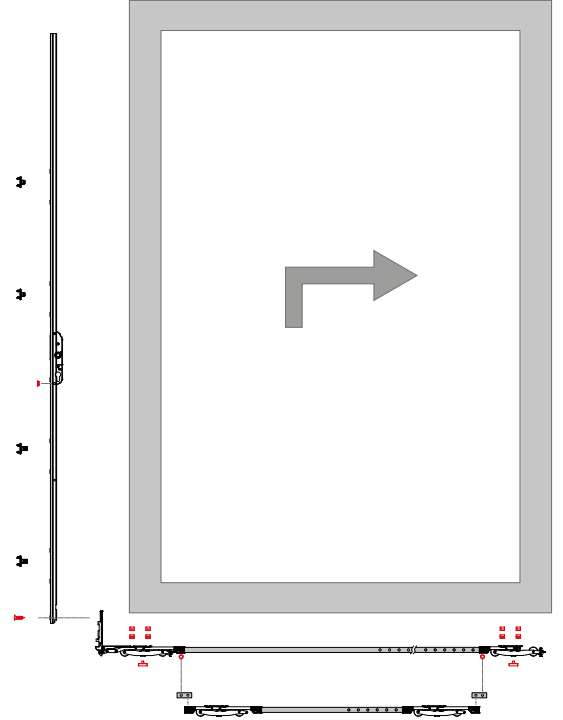

**KIT DE HOJA INTERMEDIA LS400**  
LS400 INTERMEDIATE SASH KIT

234103



50

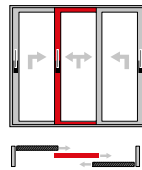
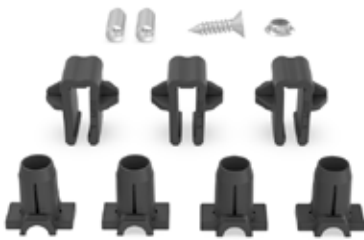

LS400

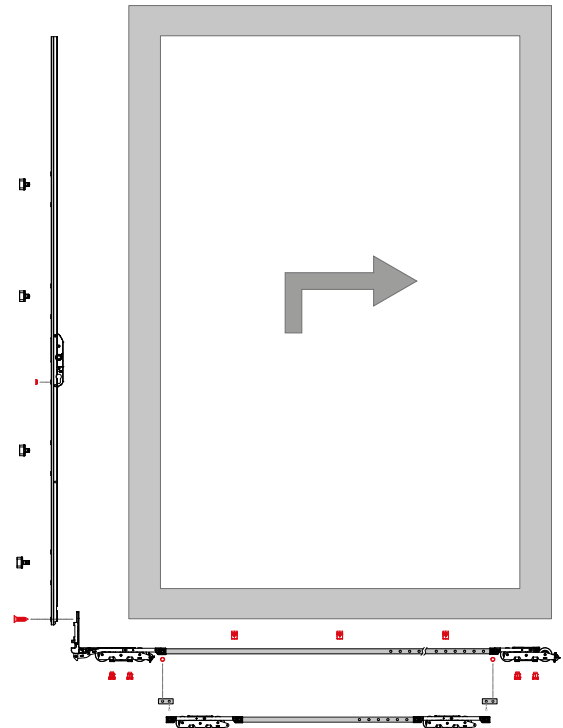



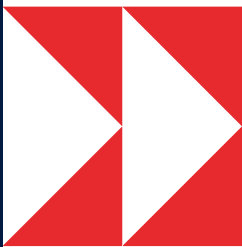

# 14

## VENTANA CORREDERA SLIDING WINDOW

- 276 **Cierres multipunto**  
Multipoint locks
- 279 **Cierres monopunto**  
Single-point locks
- 282 **Línea TITÁN**  
TITAN range
- 287 **Línea FÉNIX**  
FENIX range
- 288 **Línea FÉNIX MINI**  
FENIX MINI range
- 290 **Línea DRACO**  
DRACO range
- 292 **Microventilación**  
Micro-ventilation
- 294 **Ganchos y cerraderos**  
Nibs and keepers
- 299 **Adaptador LSPLUG**  
LSPLUG adapter
- 300 **Carros**  
Bogies



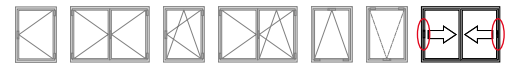

**MULTIPUNTO Aguja 7,5 mm**  
MULTIPOINT 7,5 mm backset

**M0520** Acero zincado  
Zinc plated steel

**P0520** Acero Inox AISI 304  
AISI 304 stainless steel

**ZM INX**

**AC**

7 mm

**MV**

10

Cierres multipunto para ventana correderas con 2 o 4 puntos de cierre.

Multipoint locks for sliding windows with 2 or 4 locking points.

- Los cierres multipunto están disponibles con agujas de 7,5, 15 y 30 mm.
- Disponibles en 3 tamaños diferentes: 600, 1000 y 1600 mm.
- Están equipados con dispositivo anti-levitación y tope amortiguador.
- Están disponibles con microventilación a través de la instalación del cerradero ref. 0520052, que permite un desplazamiento de la manilla de 180°.

- The multipoint locks are available with 7.5, 15 and 30 mm backsets.
- Available in 3 different sizes: 600, 1000 and 1600 mm.
- They are equipped with anti-lifting device and shock absorber stop.
- They are available with micro-ventilation opening through the installation of the keeper ref. 0520052, which allows a movement of 180° of the handle.

**MULTIPUNTO Aguja 15 mm**  
MULTIPOINT 15 mm backset

**M0521** Acero zincado  
Zinc plated steel

**P0521** Acero Inox AISI 304  
AISI 304 stainless steel

**ZM INX**

**AC**

7 mm

**MV**

10

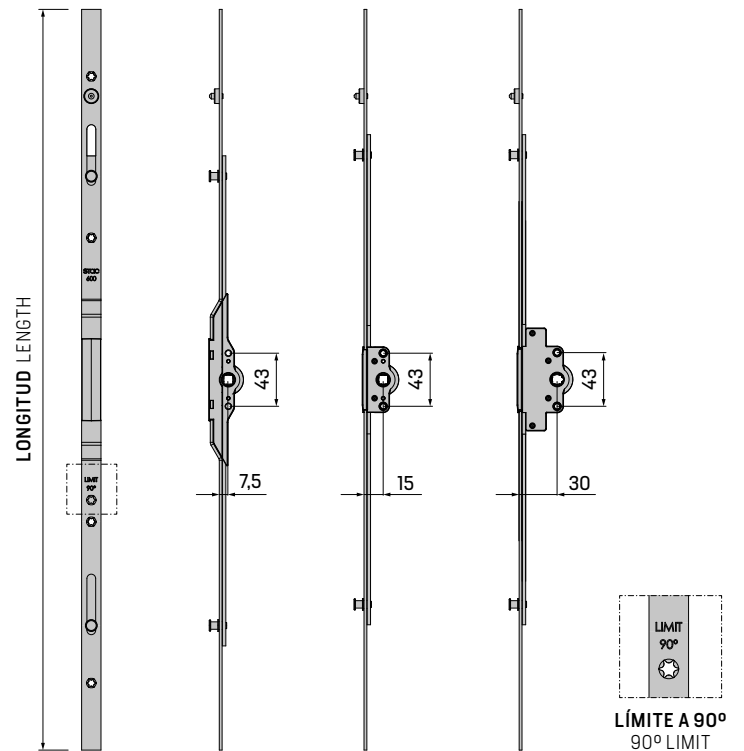

**MULTIPUNTO Aguja 30 mm**  
MULTIPOINT 30 mm backset

**A0522** Acero zincado  
Zinc plated steel

**ZM INX**

**AC**

7 mm

**MV**

6

REFERENCIA REFERENCE	AGUJA BACKSET	LONGITUD LENGTH	PTOS. CIERRE LOCKING PTS.	CALZOS SHIMS	ALTURA MÍN. HOJA MIN. SASH HEIGHT
M05200600 P05200600		600 mm	2	4	750 mm
M05201000 P05201000	7,5 mm	1000 mm	2	6	1150 mm
M05201600 P05201600		1600 mm	4	6	1750 mm
M05210600 P05210600		600 mm	2	4	750 mm
M05211000 P05211000	15 mm	1000 mm	2	6	1150 mm
M05211600 P05211600		1600 mm	4	6	1750 mm
A05220600		600 mm	2	4	750 mm
A05221000	30 mm	1000 mm	2	6	1150 mm
A05221600		1600 mm	4	6	1750 mm

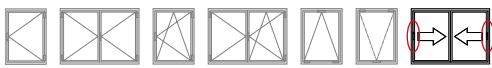

Multipoint locks for sliding windows with 2 or 3 locking points.

- The multipoint locks are available with 7.5 and 15 mm backsets.
- Available in 4 different sizes: 400, 600, 1000 and 1600 mm.
- They are equipped with anti-lifting device and shock absorber stop.
- The locking points are made of zinc-plated steel.

Cierres multipunto para ventanas correderas con 2 o 3 puntos de cierre.

- Los cierres multipunto están disponibles con agujas de 7,5 y 15 mm.
- Disponibles en 4 tamaños diferentes: 400, 600, 1000 y 1600 mm.
- Están equipados con dispositivo anti-elevación y tope amortiguador.
- Los puntos de cierre están fabricados en acero zincado.

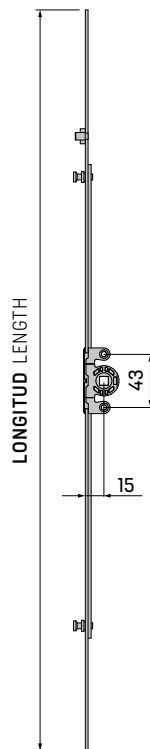
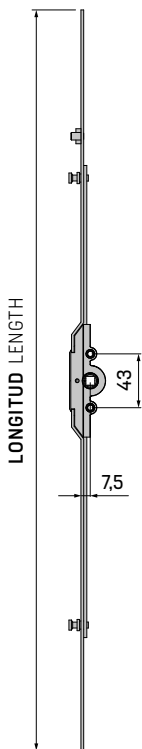

**MULTIPUNTO ECO Aguja 7,5 mm**  
ECO MULTIPOINT 7,5 mm backset

S0520

ZM INX

AC

7 mm

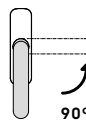

**MULTIPUNTO ECO Aguja 15 mm**  
ECO MULTIPOINT 15 mm backset

S0521

ZM INX

AC

7 mm

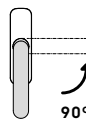

REFERENCIA REFERENCE	AGUJA BACKSET	LONGITUD LENGTH	PTOS. CIERRE LOCKING PTS.	CALZOS SHIMS	ALTURA MÍN. HOJA MIN. SASH HEIGHT	
-------------------------	------------------	--------------------	------------------------------	-----------------	--------------------------------------	--

S05200400	7,5 mm	400 mm	2	4	550	50
S05200600		600 mm	2	4	750	50
S05201000		1000 mm	3	7	1150	50
S05201600		1600mm	3	7	1750	20
S05210400	15 mm	400 mm	2	4	550	50
S05210600		600 mm	2	4	750	50
S05211000		1000 mm	3	7	1150	50
S05211600		1600mm	3	7	1750	20

■ MECANIZADOS DEL PERFIL PROFILE MACHINING

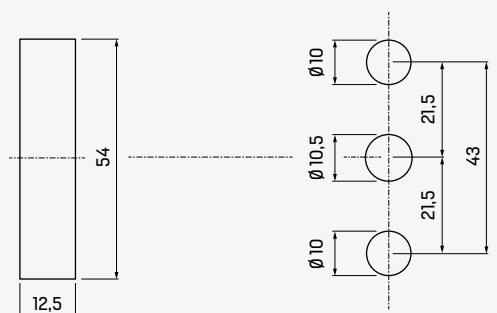

MULTIPUNTO MULTIPOINT

MANILLA HANDLE

# CIERRES MULTIPUNTO CON LLAVE

## MULTIPOINT LOCKS WITH KEY

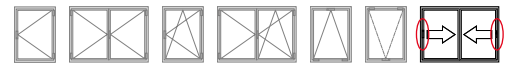

### MULTIPUNTOS CON LLAVE

#### MULTIPOINTS WITH KEY

**P0523**

**Acabado en zinc / níquel**  
 Zinc / Nickel finish

**0523**

**Acero zincado**  
 Zinc plated steel

Cierres multipunto con llave para ventanas correderas con 3 o 4 puntos de cierre.

Multipoint locks with key for sliding windows with 2 or 4 locking points.

- Los cierres multipunto están disponibles con aguja de 15 mm.
- Disponibles en 2 tamaños diferentes: 1600 y 1800 mm.
- Están equipados con dispositivo anti-levitación y tope amortiguador.
- Cierres multipunto especialmente diseñados para puertas balconeras con acceso a la calle.
- La cerradura es válida para cilindro de perfil europeo con leva larga de 15 mm.
- Los cierres están disponibles con acabado de protección anticorrosión para ambientes de alta salinidad que ofrece una resistencia a la corrosión en las pletinas de más de 800 horas en cámara de niebla salina (ref. P0523).

- The multipoint locks are available with 15 mm backset.
- Available in 2 different sizes: 1600 and 1800 mm.
- They are equipped with anti-lifting device and shock absorber stop.
- Multipoint locks specially designed for balcony doors with access to the street.
- The lock is valid for Euro Groove profile cylinder with 15 mm long cam.
- The multipoint locks are available with anti-corrosion protection finish for high salinity environments that offers corrosion resistance in the platens of more than 800 hours in saline mist chamber (ref. P0523).

#### MECANIZADOS DEL PERFIL PROFILE MACHINING

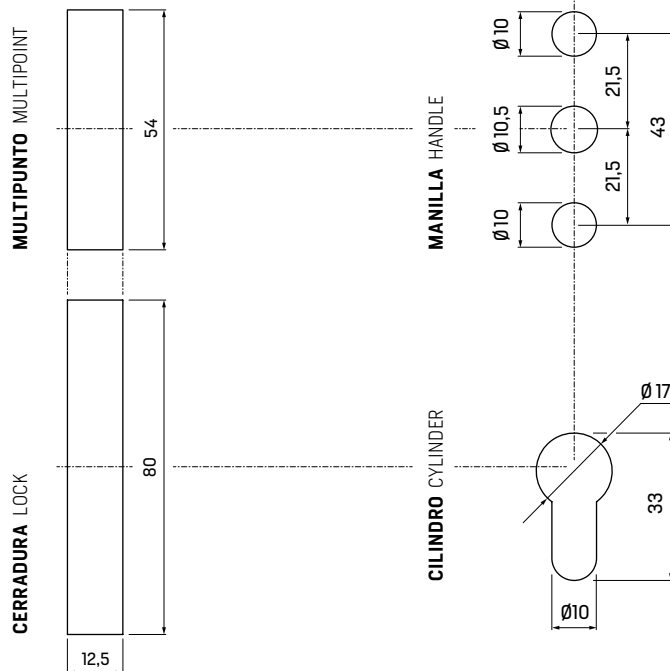
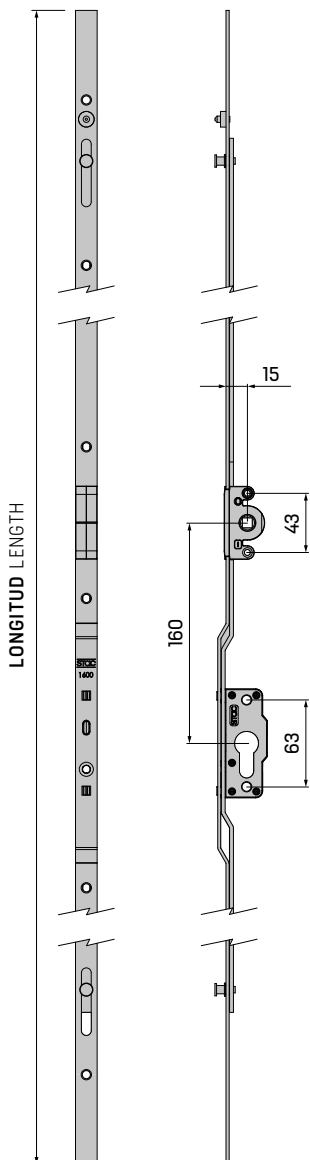

REFERENCIA REFERENCE	AGUJA BACKSET	LONGITUD LENGTH	PUNTOS DE CIERRE LOCKING POINTS	CALZOS SHIMS	ALTURA MÍN. DE HOJA MINIMUM SASH HEIGHT
05231600	15 mm	1600 mm	3	10	1750 mm
05231800		1800 mm	4	10	1950 mm
P05231600		1600 mm	3	10	1750 mm
P05231800		1800 mm	4	10	1950 mm

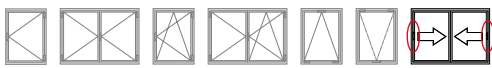

## CIERRES MONOPUNTO 180

### 180 SINGLE-POINT LOCKS

Single-point locks for sliding windows with 1 locking point.

- The single-point locks are available with 7.5 and 15 mm backsets.
- The opening movement at 180° from the lock allows the incorporation of micro-ventilation.
- They are equipped with anti-lifting device and shock absorber stop.

Cierres monopunto para ventanas correderas con 1 punto de cierre.

- Los cierres monopunto están disponibles con agujas de 7,5 y 15 mm
- El movimiento de apertura a 180° del cierre permite la incorporación de microventilación.
- Están equipados con dispositivo anti-levitación y tope amortiguador.

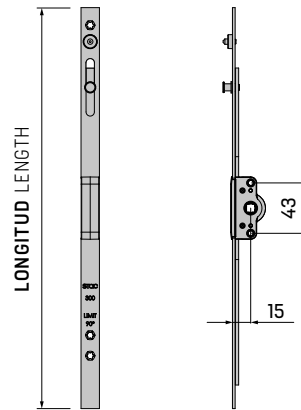
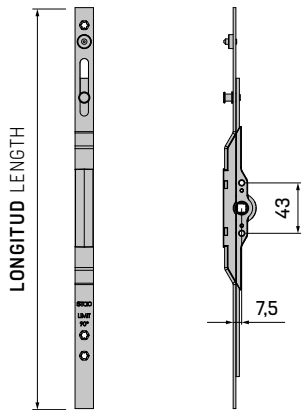

### MONOPUNTO 180 Aguja 7,5 mm

#### 180 SINGLE-POINT LOCK 7,5 mm backset

M05250300



### MONOPUNTO 180 Aguja 15 mm

#### 180 SINGLE-POINT 15 mm backset

M05240300



#### ▶ MANILLA ESTÁNDAR STANDARD HANDLE

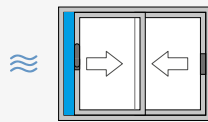

#### ▶ MANILLA ENRASADA FLUSH HANDLE

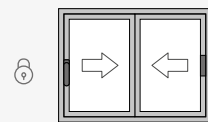
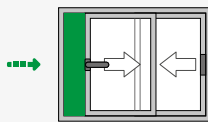
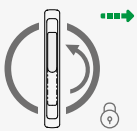

REFERENCIA REFERENCE	AGUJA BACKSET	LONGITUD LENGTH	PUNTOS DE CIERRE LOCKING POINTS	CALZOS SHIMS
M05240300	15 mm	365 mm	1	2
M05250300	7,5 mm	380 mm	1	2

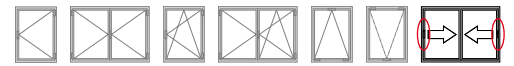

**CERRADERO DE MICROVENTILACIÓN**  
MICRO-VENTILATION KEEPER

0520052

15

ZM INX

AC

7 mm

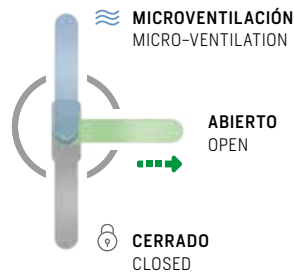
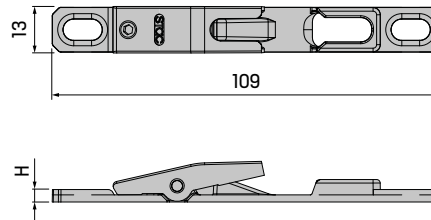
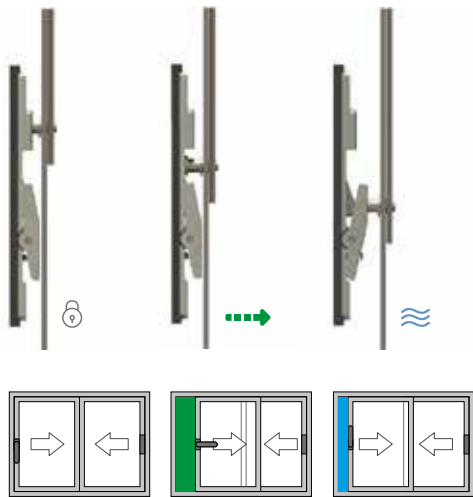

Cerraderos para cierres multipunto.

• Los cerraderos para multipunto disponen de calzos para adaptarse a las diferentes series de perfil del mercado.

**Cerradero de microventilación**

- El cerradero permite la posición de aireación en ventanas correderas.
- Cerradero de microventilación con una permeabilidad al aire según norma UNE-EN 12207: 2017 en la posición de apertura de clase I.
- El cerradero dispone de 3 posiciones que permiten la microventilación.
- Apertura en microventilación de 4 mm, regulable hasta 6 mm.

Keepers for multipoint locks.

• The multipoint keepers have shims to adapt to the different profile series on the market.

**Micro-ventilation keeper**

- The keeper allows the position of ventilation in sliding windows.
- Micro-ventilation keeper with air permeability according to the standard UNE-EN 12207: 2017 in the opening position of class I.
- The keeper has 3 positions that allow micro-ventilation.
- Micro-ventilation opening of 4 mm, adjustable up to 6 mm.

**CERRADERO**  
KEEPER

A0520001

400

INX

7 mm

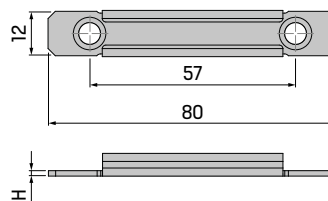

La referencia A0520001 no incluye calzos  
Reference A0520001 does not include shims

REF.	CALZO SHIM	H
		1,7 mm
		2 mm
0520052		3 mm
		4 mm

REF.	CALZO SHIM	H
0520003		1,7 mm
A0520002		2 mm
0520004		3 mm
0520005		4 mm

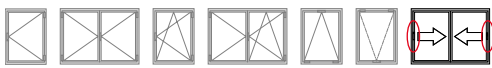

## CALZOS PARA CIERRES MULTIPUNTO SHIMS FOR MULTIPOINT LOCKS

Shims to adapt the multipoint locks to the different series on the market.

Calzos para adaptar los multipuntos a las diferentes series del mercado.

• Shims manufactured in ABS to provide rigidity and stability to the fixation.

• Calzos fabricados en ABS para aportar rigidez y estabilidad a la fijación.

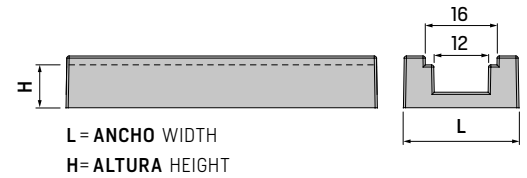

L = ANCHO WIDTH  
H = ALTURA HEIGHT

REFERENCIA REFERENCE	DIMENSIONES DIMENSIONS	PEDIDO MÍN. MIN. REQUEST
0599595		2000
0599596		2000
0599597		2000
0599675		200
0520006		-
0520007		100
0520008		-
0520009		-
0520010		-
0520011		100

REFERENCIA REFERENCE	DIMENSIONES DIMENSIONS	PEDIDO MÍN. MIN. REQUEST
0520012		-
0520013		400
0520014		400
0520015		200
0520016		200
0520017		200
0520049		2000
0520050		2000
0520146		-

# TITAN

## HERRAJE PARA VENTANAS CORREDERAS SLIDING WINDOW HARDWARE



**Instalación rápida**  
Quick assembly



**Regulaciones simples**  
Easy adjustments



**Sin tornillos visibles**  
No visible screws



**Carta de colores RAL**  
RAL colour chart

En STAC nos hemos propuesto evolucionar nuestra gama de cierres y tiradores TITÁN para ventanas correderas con un diseño moderno pero sobre todo incorporando nuevas soluciones.

### » **Estética actualizada**

Actualizar las líneas de diseño y aportar limpieza han sido los objetivos estéticos planteados a la hora de desarrollar la línea TITÁN, obteniendo una línea de productos moderna y elegante que no deja a la vista ningún sistema de fijación.

### » **Simplicidad de montaje**

Montaje automático. Cierres de embutir y uñero están provistos de un sistema de montaje automático que admite dispersiones en el largo del cajado de  $\pm 3$  mm, así como unas alas más anchas que ocultan cualquier error de mecanizado.

Accionamiento automático - manual. A través de la simple extracción de un muelle se ha facilitado al máximo el paso de un accionamiento automático a un accionamiento manual del cierre.

### » **Seguridad**

Sistema de anclaje. El sistema de anclaje pasa de estar en la parte inferior a la parte superior. De este modo el desmontaje del cierre es menos intuitivo, ya que los cierres se accionan presionando hacia abajo.

Sistema de retención. El sistema de retención con acceso frontal impide el desmontaje del cierre de la ventana tras su instalación.

Cierres de embutir con y sin llave. Para los clientes en busca de una mayor seguridad, se encuentra disponible una versión con cerradura accionada por llave para bloquear la apertura de la ventana.

At STAC we set out to evolve our TITAN range of recessed handles and pull handles for sliding windows with a modern design but above all incorporating new solutions.

### » **Up-to-date style**

To update the lines of design and to contribute cleanliness have been the aesthetic objectives raised at the time of developing the TITAN range, achieving a modern and elegant product line which keeps the attachment system hidden.

### » **Easy assembly**

Automatic installation. Both the recessed handles and finger pull have an automatic installation system which allows for differences in the length of the recess of  $\pm 3$  mm and also have wider flanges to hide any mechanized imperfections.

Automatic - Manual closing action. By simply removing a spring, the change from automatic to manual operation of the recessed handle is made as easy as possible.

### » **Security**

Fixing system. The position of the fixing system is changed from the lower to the upper part. This makes the removal of the handle less intuitive, as the recessed handles are operated by pressing down.

Retention system. The retention system with frontal access prevents the dismantling of the window recessed handle after its installation.

Recessed handles with and without key. For customers seeking greater security, a version with a key operated lock is available to lock the opening of the window.



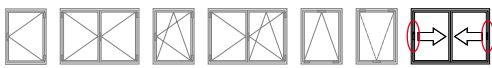

Handle with a design that is flush with the sash profile and which allows the leaves to pass each other in sliding windows.

- The flush handle takes advantage of the unique features of the STAC multipoint locks that allow the movement of the 7 mm spindle from up to 180°.
- The flush handle has three different spindle length options for use with different series, the 28 mm spindle being the minimum sash profile width permitted.
- The flush handle maintains the machining dimensions for the assembly of the recessed handles.
- Includes quick mounting plastic covers for the fixing screws.

Manilla con diseño a ras del perfil de hoja que permite el cruce de hojas en ventanas correderas.

- La manilla aprovecha las características únicas de los cierres multipunto de STAC que permiten el movimiento del cuadradillo de 7 mm hasta 180°.
- Disponible en 3 longitudes de cuadradillo diferentes con el objetivo de adaptarse a diferentes series, siendo 28 mm la medida mínima de ancho de perfil de hoja permitido.
- La manilla mantiene las cotas de mecanizado para el montaje de los cierres de embutir.
- Incluye tapas plásticas de montaje rápido para los tornillos de fijación.

**MANILLA ENRASADA TITÁN**  
TITAN FLUSH HANDLE

**	□ 7x15 mm	<b>034410</b>	**
<b>RAL</b>	□ 7x25 mm	<b>034420</b>	**
<b>ZM INX</b>	□ 7x12 mm	<b>034430</b>	**
<b>PA</b>			
● 7 mm			

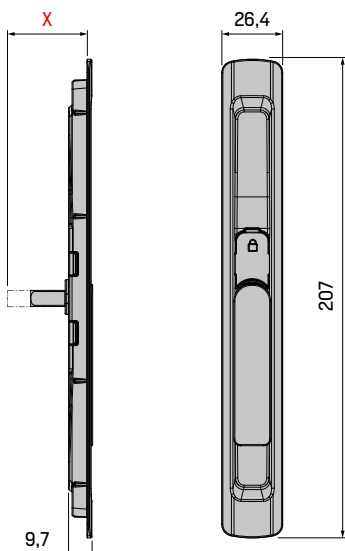

REFERENCIA REFERENCE		CUADRADILLO SPINDLE	X
034410	**	15 mm	24,5 mm
034420	**	25 mm	34,5 mm
034430	**	12 mm	21,5 mm

ANCHO MÍNIMO DEL PERFIL MINIMUM WIDTH PROFILE	
<b>CIERRE MULTIPUNTO CON AGUJA 7,5 mm</b> MULTIPOINT LOCK WITH 7,5 mm BACKSET	32 mm
<b>CIERRE MULTIPUNTO CON AGUJA 15 mm</b> MULTIPOINT LOCK WITH 15 mm BACKSET	28 mm

\* **RADIO DE MECANIZADO MÁX.**  
MAXIMUM MACHINING RADIUS

■ **ESPESOR MÍNIMO DE HOJA (MANILLA ENRASADA + UÑERO TIRADOR)**  
MINIMUM SASH THICKNESS (FLUSH HANDLE + FINGER PULL)

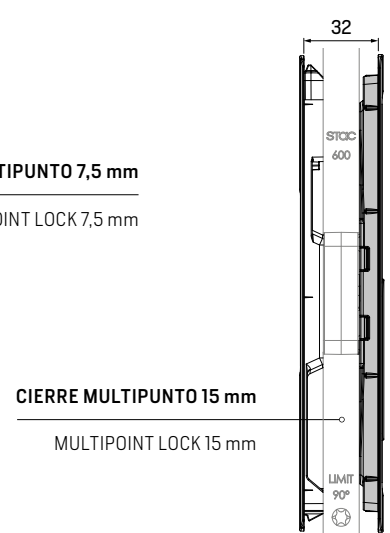
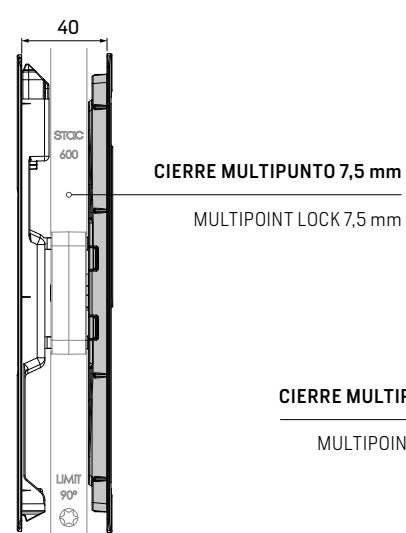
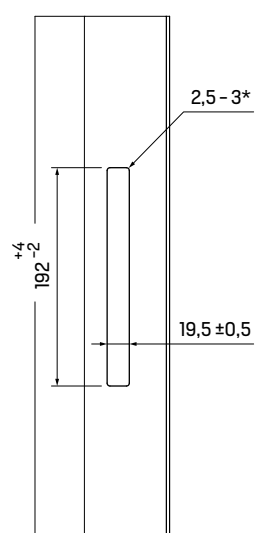
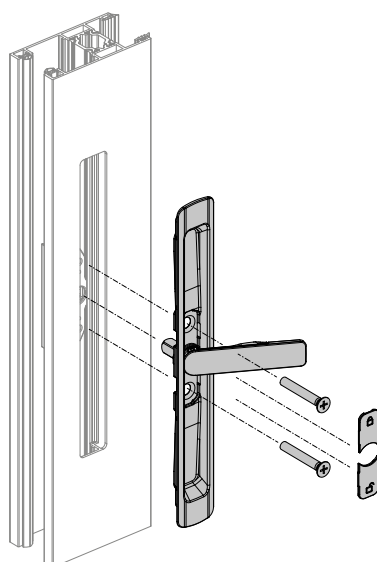

## CIERRES DE EMBUTIR TITÁN

TITAN RECESSED HANDLES

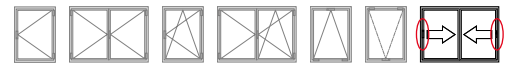

### CIERRE DE EMBUTIR TITÁN SIN LLAVE

TITAN RECESSED HANDLE WITHOUT LOCK

034000 \*\*

40



Cierres automontables que permiten la apertura de ventanas correderas.

- Los cierres permiten el cruce y la superposición de las hojas correderas.
- Ensamblados para función automática, es posible pasar a función manual retirando solamente un muelle.
- Los cierres incluyen sistema de regulación del gancho con acceso desde la parte frontal de los mismos.
- Incluyen sistema de retención mediante tornillo prisionero con el objetivo de evitar el desmontaje.
- Los cierres permiten ser ensamblados manualmente sin necesidad de maquinaria especial.

Self-assembly recessed handles that allow the opening of sliding windows.

- The recessed handles allow the crossing and overlapping of the sliding leaves.
- Assembled for automatic operation, it is possible to switch to manual operation by removing only a spring.
- The recessed handles include a hook adjustment system with access from the front.
- The recessed handles include a retaining system by means of a set screw in order to avoid disassembly.
- The recessed handles can be assembled manually without the need for special machinery.

### CIERRE DE EMBUTIR TITÁN CON LLAVE

TITAN RECESSED HANDLE WITH LOCK

034100 \*\*

40

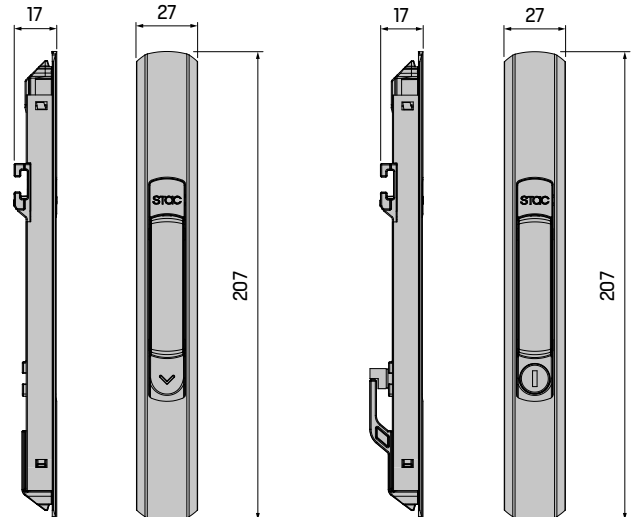

#### MECANIZADO MACHINING TITÁN

#### CONFIGURACIÓN DEL MODO AUTOMÁTICO A MODO MANUAL SETTING THE AUTOMATIC MODE TO MANUAL MODE

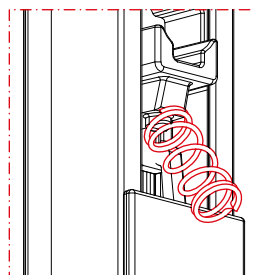
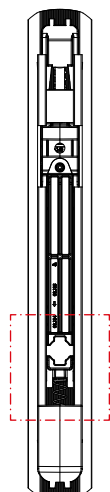
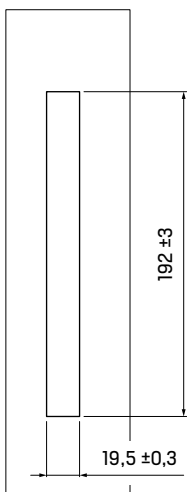

**Liberar el muelle trasero para pasar de operación automática a manual**  
Release the rear spring to switch from automatic to manual operation

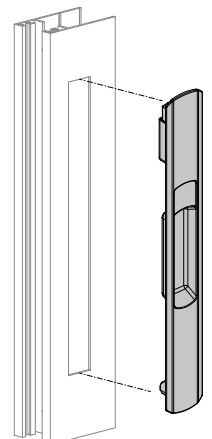
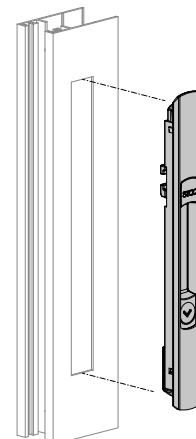

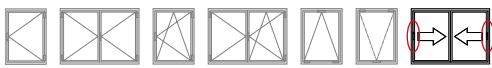

External finger pull and pull handle that allow the opening of sliding windows.

- The finger pull allow the crossing and overlapping of the sliding leaves.
- Quick fixing to the profile by pressing on the upper part of the finger pull without using screws.

**Pull handle**

- The pull handle is recommended for use as exterior hardware on large sliding windows.
- The pull handle is valid for any type of window opening.
- Front installation of the pull handle without any pre-machining of the profile.

Uñero y tirador exteriores que permiten la apertura de ventanas correderas.

- El uñero permite el cruce y la superposición de las hojas correderas.
- Fijación rápida al perfil presionando en la parte superior del uñero sin necesidad de utilizar tornillería.

**Tirador**

- Se recomienda el uso del tirador como herraje exterior en ventanas correderas de grandes dimensiones.
- El tirador es válido para cualquier tipo de apertura de ventana.
- Instalación frontal del tirador sin necesidad de mecanizados previos en el perfil.

**UÑERO TITÁN**  
TITAN FINGER PULL



0342000 \*\*



**TIRADOR TITÁN**  
TITAN PULL HANDLE



034500 \*\*

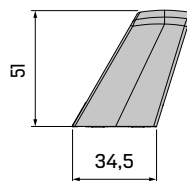
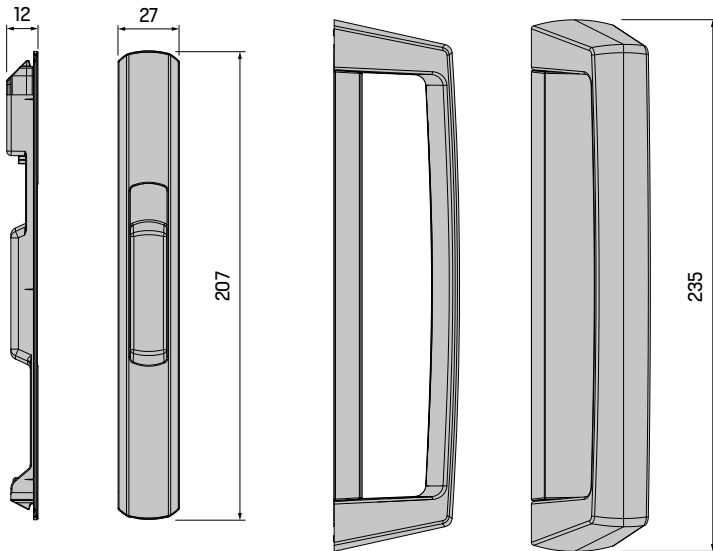

■ **ESPESOR MÍNIMO DE HOJA** MINIMUM SASH THICKNESS

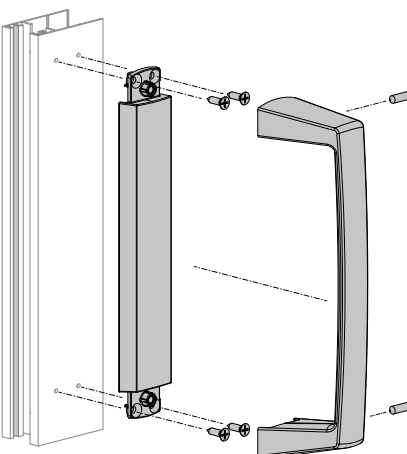
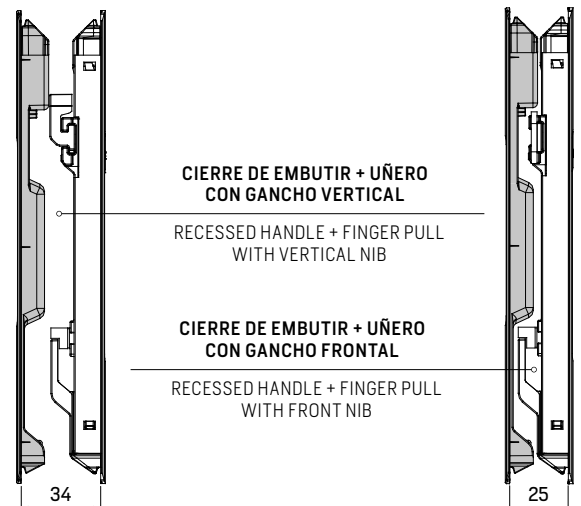

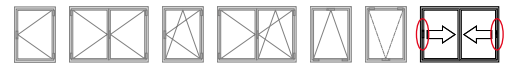

**TIRADOR TITÁN PARA CIERRE DE EMBUTIR**  
TITAN PULL HANDLE FOR RECESSED HANDLE

034300 \*\*

15



Tiradores que permiten la apertura de correderas de grandes dimensiones.

Active pull handles that allow the opening of large sliding windows.

**Tirador para cierre de embutir**

- El tirador se usa siempre en combinación con un cierre de embutir.
- Diseño totalmente integrado que impide la visión de los tornillos de fijación.
- Sistema de fijación al perfil a través de tornillos autorroscantes.

**Pull handle for recessed handle**

- The pull handle is always used in combination with a recessed handle.
- Fully integrated design that prevents the vision of the fixing screws.
- Fixing system to the profile by means of self-tapping screws.

**Tirador para cierre multipunto**

- El mecanismo del tirador permite girar 90° el cuadradillo.
- El tirador se adapta a cualquier tipo de cierre multipunto.
- La fijación del tirador es independiente del bloqueo del cierre multipunto.

**Pull handle for multipoint lock**

- The mechanism allows the spindle to be rotated by 90°.
- The pull handle is suitable for any type of multipoint locks.
- The fixing of the pull handle is independent of the locking of the multipoint.

**TIRADOR TITÁN PARA CIERRE MULTIPUNTO**  
TITAN PULL HANDLE FOR MULTIPOINT LOCK

034600 \*\*

10

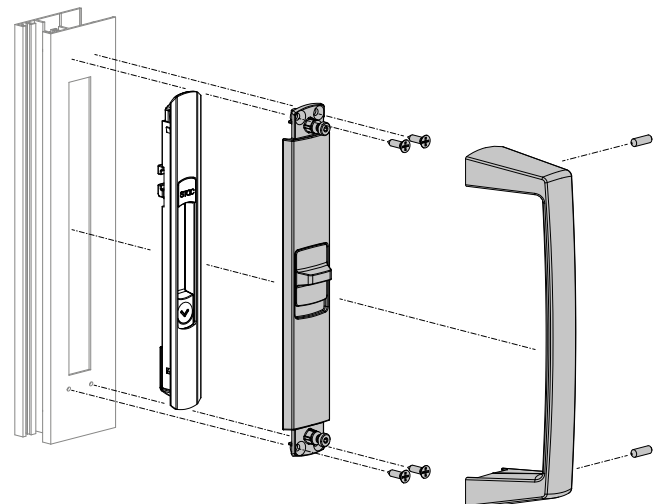
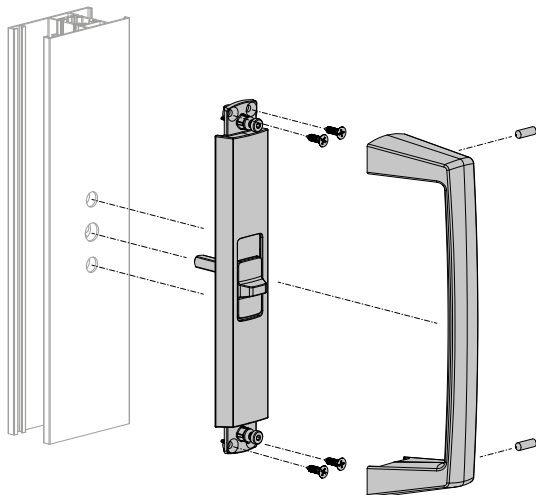
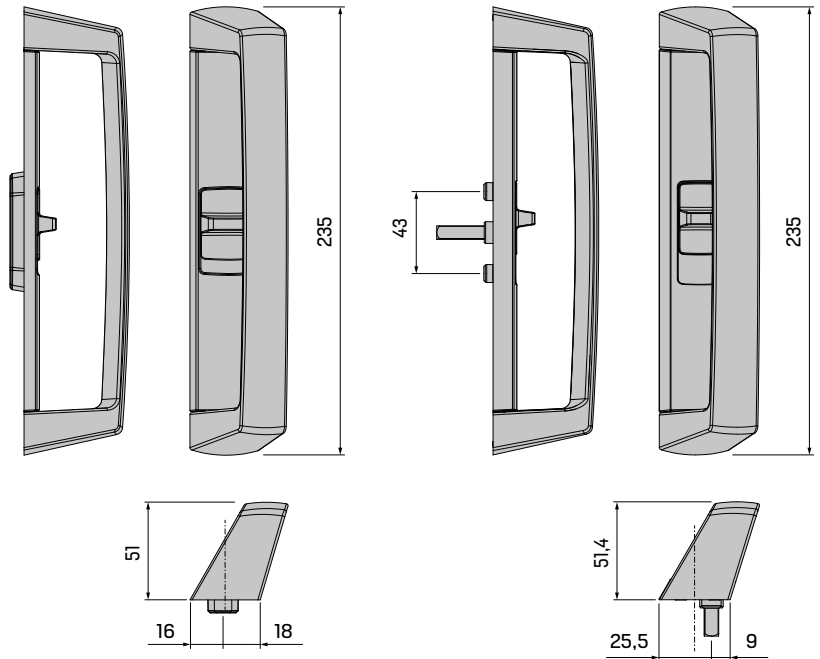

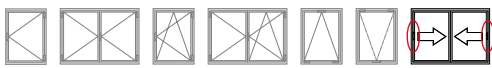

## CIERRES DE EMBUTIR FÉNIX FENIX RECESSED HANDLES

Self-assembly recessed handles that allow the opening of sliding windows.

- The recessed handles allow the crossing and overlapping of the sliding leaves.
- Quick fixing to the profile by pressing on the bottom of the handle without using self-tapping screws.
- Damping system in the nib that allows it to descend when the sash is closing, with the push button remaining static.

### Finger pull

- The finger pull allow the crossing and overlapping of the sliding leaves.
- Optionally the finger pull can be fixed with screws from the inside for more security.

Cierres automontables que permiten la apertura de ventanas correderas.

- Los cierres permiten el cruce y la superposición de las hojas correderas.
- Fijación rápida al perfil presionando en la parte inferior del cierre sin necesidad de usar tornillos autorroscantes.
- Sistema de amortiguación en el gancho que permite su descenso en el momento de cerrar la hoja, permaneciendo estático el botón pulsador.

### Uñero

- El uñero permite el cruce y la superposición de las hojas correderas.
- Opcionalmente el uñero puede fijarse con tornillos desde el interior para mayor seguridad.

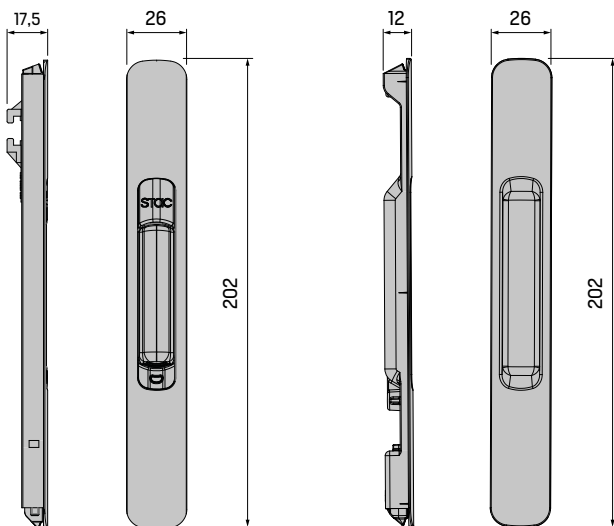

■ MECANIZADO MACHINING  
FÉNIX

■ ESPESOR MÍNIMO DE HOJA  
MINIMUM SASH THICKNESS

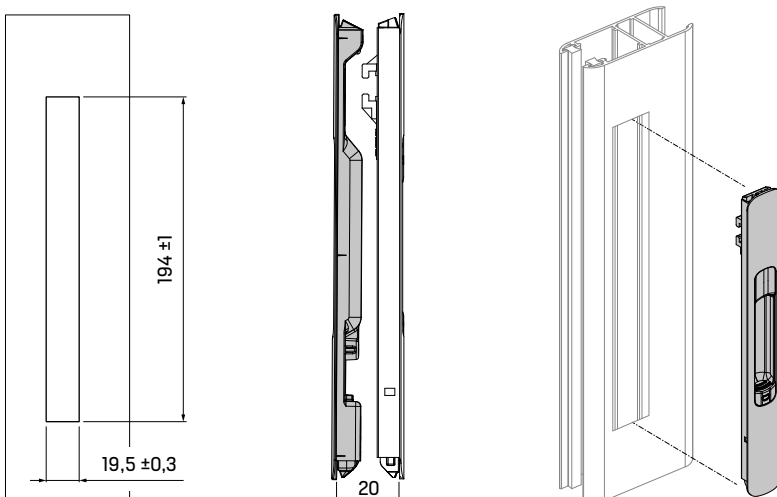

## CIERRE DE EMBUTIR AUTOMÁTICO FÉNIX FENIX AUTOMATIC RECESSED HANDLE



032000 \*\*

40



## CIERRE DE EMBUTIR MANUAL FÉNIX FENIX MANUAL RECESSED HANDLE



032000 \*\* C

40



## UÑERO FÉNIX FENIX FINGER PULL



032100 \*\*

50



## CIERRES DE EMBUTIR FÉNIX FENIX RECESSED HANDLES

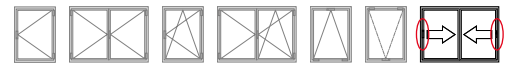

### CIERRE DE EMBUTIR FÉNIX MINI FENIX MINI RECESSED HANDLE

B03300 \*\*

40



Cierres automontables que permiten la apertura de ventanas correderas.

- Los cierres permiten el cruce y la superposición de las hojas correderas.
- Fijación rápida al perfil presionando en la parte inferior del cierre sin necesidad de usar tornillos autorroscantes.
- Alta tolerancia en el mecanizado del perfil gracias a su sistema de fijación.
- Por defecto, los cierres de embutir funcionan en modo automático pudiendo configurarse en modo manual.

Self-assembly recessed handles that allow the opening of sliding windows.

- The recessed handles allow the crossing and overlapping of the sliding leaves.
- Quick fixing to the profile by pressing on the bottom of the handle without using self-tapping screws.
- High tolerance in the machining of the profile thanks to its fixing system.
- By default, the recessed handles work in automatic mode and can be set to manual mode.

### CIERRE DE EMBUTIR FÉNIX MICRO FENIX MICRO RECESSED HANDLE

035000 \*\*

40

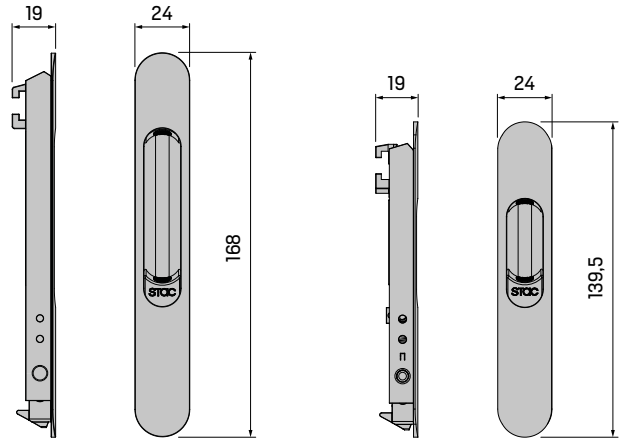

#### ■ MECANIZADO MACHINING FÉNIX MINI

#### ■ MECANIZADO MACHINING FÉNIX MICRO

#### ■ CONFIGURACIÓN DEL MODO AUTOMÁTICO A MODO MANUAL SETTING THE AUTOMATIC MODE TO MANUAL MODE

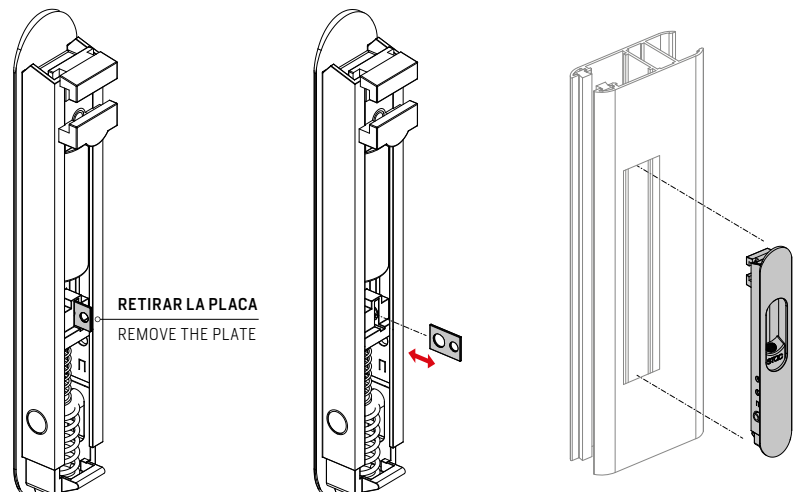
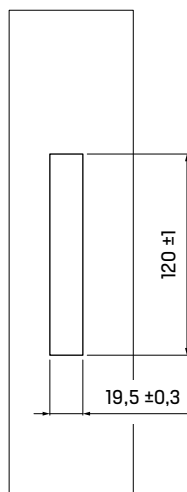
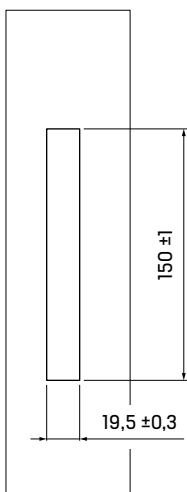

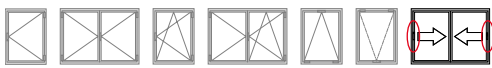

Optional pull handles that allow the opening of sliding windows.

- The pull handle is always used in combination with a recessed handle.
- The pull handle is recommended for use as exterior hardware on large sliding windows.
- The fixing screws are available in different finishes depending on the finish of the pull handle.
- The pull handles offer the possibility of fixing by means of riveted nuts (not included).

Tiradores opcionales que permiten la apertura de ventanas correderas.

- El tirador se usa siempre en combinación con un cierre de embutir.
- Se recomienda el uso del tirador como herraje exterior en ventanas correderas de grandes dimensiones.
- Los tornillos de fijación están disponibles en diferentes acabados en función del acabado del tirador.
- Los tiradores ofrecen la posibilidad de fijación por medio de tuercas remachadas (no incluidas).

**TIRADOR FÉNIX**  
FENIX PULL HANDLE



0320 \*\*

50



**TIRADOR FÉNIX MINI**  
FENIX MINI PULL HANDLE



0503087 \*\*

40

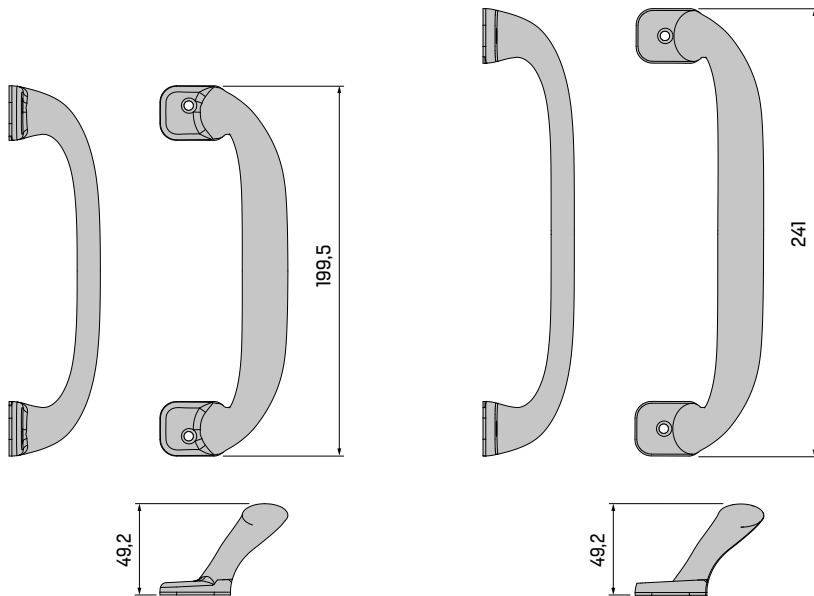

■ MECANIZADO MACHINING  
FÉNIX

■ MECANIZADO MACHINING  
FÉNIX MINI

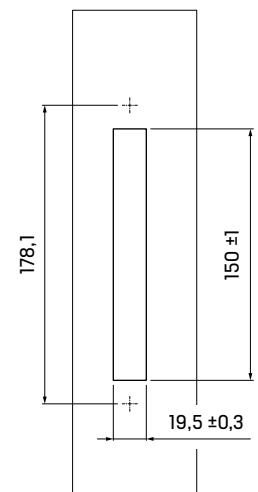
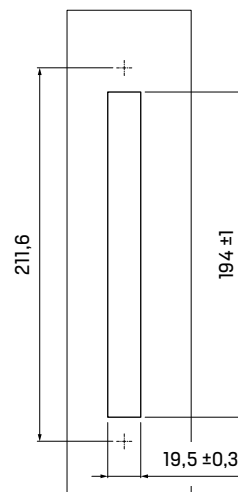
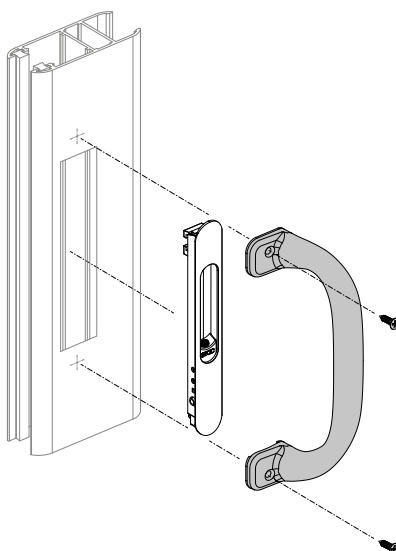

## CIERRES DE EMBUTIR DRACO

DRACO RECESSED HANDLES

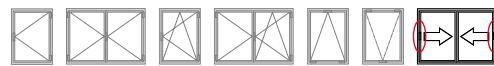

### CIERRES DE EMBUTIR DRACO MAX

DRACO MAX RECESSED HANDLE

031000 \*\*

**Automático**  
Automatic

031000 \*\* C

**Manual**  
Manuál

50



\*\*



ANODIC

AL INX

PP

Cierres de embutir que permiten la apertura de ventanas correderas.

- Disponibles dos modelos de cierre de embutir: DRACO MAX y DRACO LINE.
- Los cierres están disponibles con configuración automática o manual.
- Los tornillos de fijación extraplano están disponibles en múltiples acabados: acero inoxidable, lacado blanco, pavonado negro o dorado.
- El gancho, el contracierre y los tornillos de fijación se suministran en función del sistema de carpintería a emplear.

Recessed handles that allow the opening of sliding windows.

- Two models are available: DRACO MAX and DRACO LINE.
- The recessed handles are available with automatic or manual configuration.
- The extra-flat fixing screws of the recessed handles are available in multiple finishes: stainless steel, white powder coated, black or gold blueing.
- The nib, the keeper and the screws are supplied according to the windows system to be used.

### CIERRES DE EMBUTIR DRACO LINE

DRACO LINE RECESSED HANDLE

030000 \*\*

**Automático**  
Automatic

030000 \*\* C

**Manual**  
Manual

50



\*\*



ANODIC

AL INX

PP

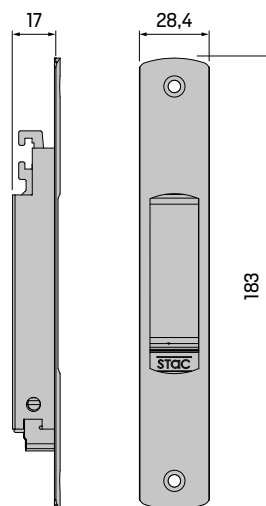

■ DRACO MAX

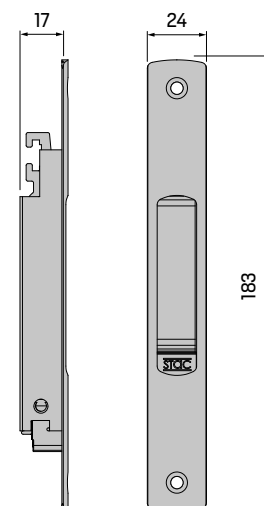

■ DRACO LINE

■ MECANIZADO MACHINING  
DRACO MAX

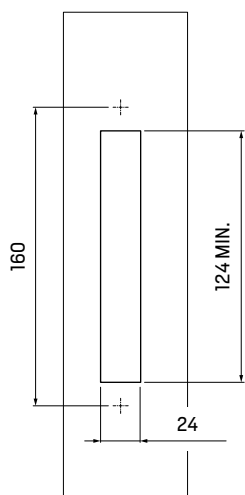

■ MECANIZADO MACHINING  
DRACO LINE

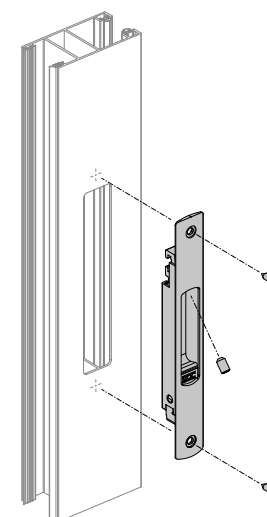
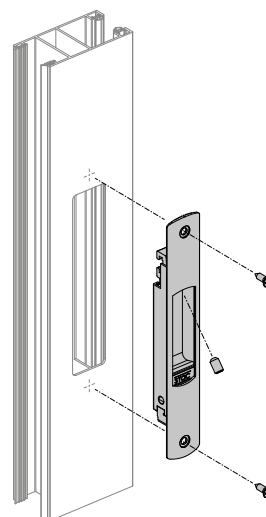
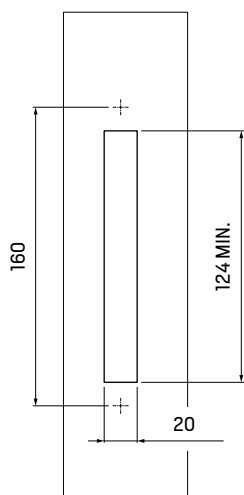



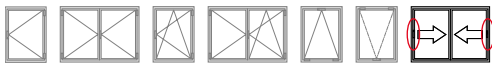

Optional pull handle that allow the opening of sliding windows.

- The pull handle is always used in combination with a recessed handle.
- The pull handle is recommended for use as exterior hardware on large sliding windows.
- The fixing screws are available in different finishes to match the DRACO recessed handles.

Tirador opcional que permite la apertura de ventanas correderas.

- El tirador se usa siempre en combinación con un cierre de embutir.
- Se recomienda el uso del tirador como herraje exterior en ventanas correderas de grandes dimensiones.
- Los tornillos de fijación están disponibles en diferentes acabados para combinar con los cierres de embutir DRACO.

**TIRADOR DRACO**  
DRACO PULL HANDLE



0310 \*\*

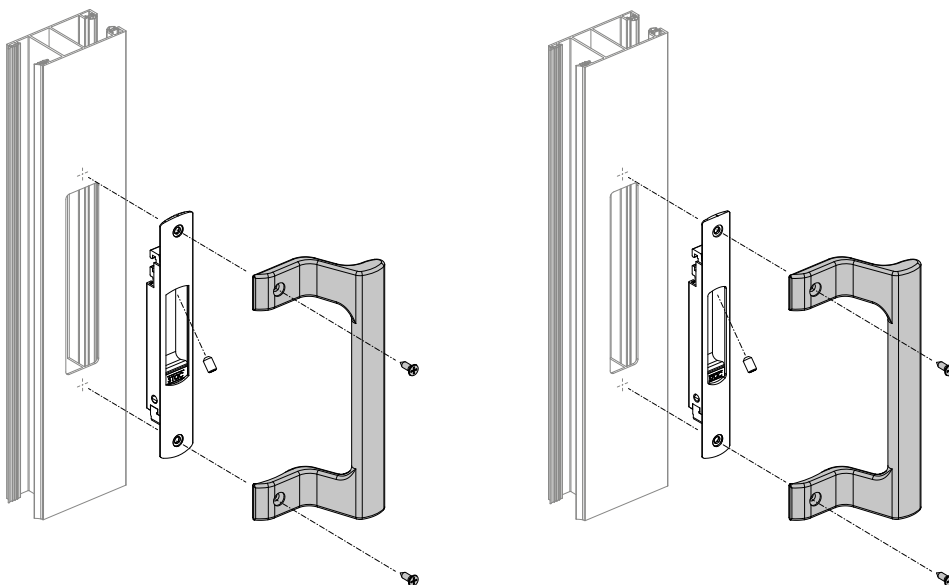
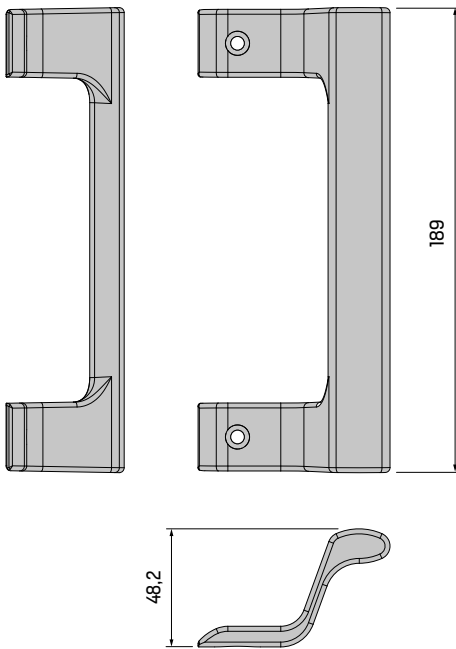

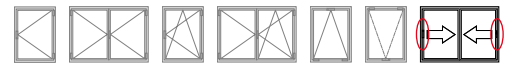

**VENTANAS CORREDERAS PERIMETRALES**

PERIMETER SLIDING WINDOWS

05034400

ZM

100

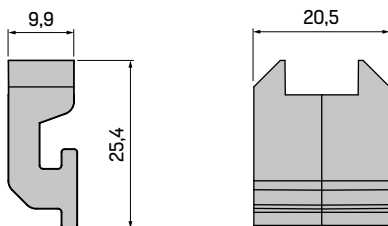
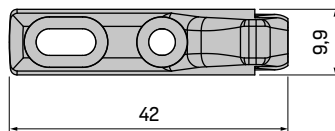
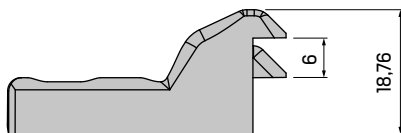

Dispositivo que permite una posición de aireación en correderas perimetrales.

- El dispositivo se instala sobre un cierre de embutir de acción automática.
- El dispositivo se compone de dos piezas: un gancho y un contracierre doble.
- El contracierre permite dos posiciones: posición de cierre y microventilación.
- El dispositivo cumple con todas las exigencias del Código Técnico de Edificación en cuanto a calidad del aire interior, garantizando la ventilación exigida.

**Ensayos (Clase 1)**

- Permeabilidad al aire según la norma UNE-EN 12207: 2017 en posición de microapertura.
- Valores obtenidos según la norma UNE-EN 1026: 2017 realizada en organismo notificado 0370 de acuerdo con el número de informe 09 / 32302411.

Device that allows an aeration position in perimeter sliding windows.

- The device is installed on a automatic-acting recessed handle.
- The device consists of two parts: a nib and a double keeper.
- The keeper allows two positions: closing position and micro-ventilation.
- The device complies with all the requirements of the Technical Building Code regarding indoor air quality, guaranteeing the required ventilation.

**Tests (Class 1)**

- Air permeability according to the UNE-EN 12207: 2017 standard in the micro-opening position.
- Values obtained in accordance with the UNE-EN 1026: 2017 standard by notified body 0370 in accordance with report number 09 / 32302411.

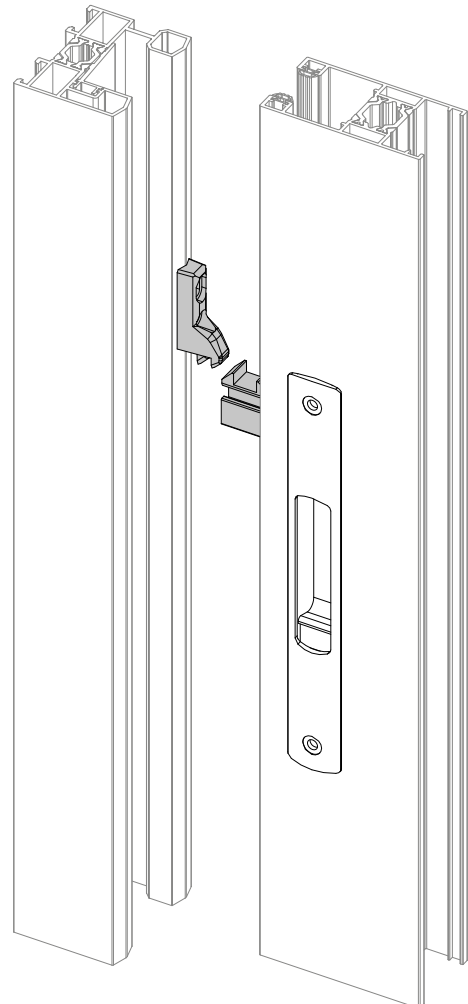

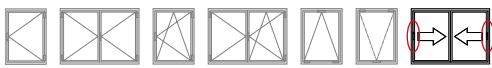

## MICROVENTILACIÓN PARA CORREDERAS DE CORTE RECTO

### MICRO-VENTILATION FOR STRAIGHT-CUT SLIDING WINDOWS

Device that allows an aeration position on straight cut sliding windows.

- The kits for straight-cut sliding windows can be customized.
- Nibs and keepers can be combined to suit different profile series.

Dispositivo que permite una posición de aireación en correderas de corte recto.

- Los kits para ventana corredera de corte recto son personalizables.
- Ganchos y contracrietas pueden combinarse para diferentes series de perfiles.

#### CORTE RECTO SERIE S5000

##### S5000 SERIES STRAIGHT-CUT

ZM INX

05035000

100



#### CORTE RECTO SERIE S5200

##### S5200 SERIES STRAIGHT-CUT

ZM INX

05035200

100

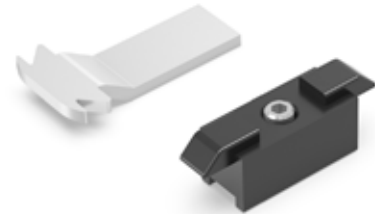

#### CORTE RECTO SERIE S6200

##### S6200 SERIES STRAIGHT-CUT

ZM INX

05036200

100

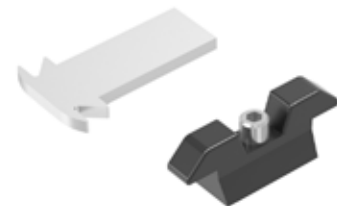

#### CORTE RECTO SERIE S6500

##### S6500 SERIES STRAIGHT-CUT

ZM INX

03KT6502

100

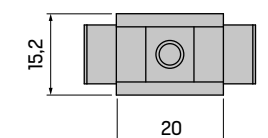
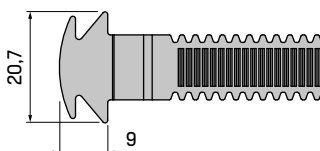
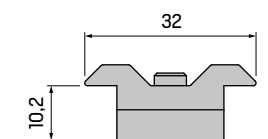
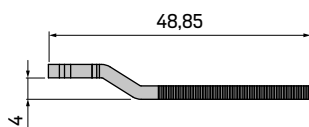
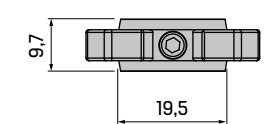
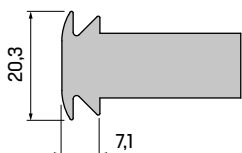
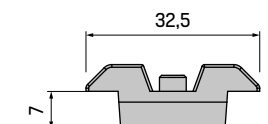
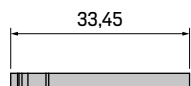
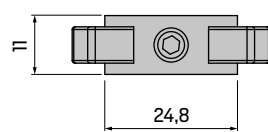
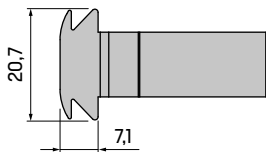
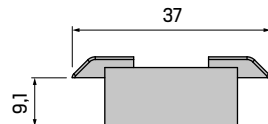
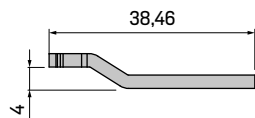
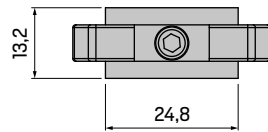
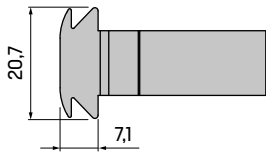
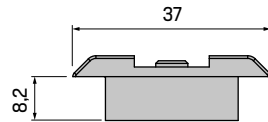
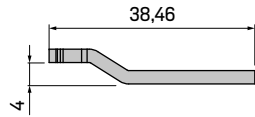
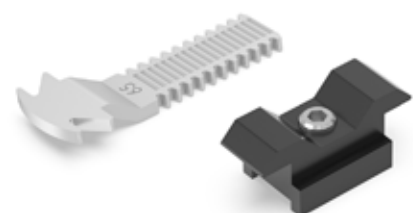

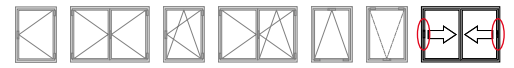

**GANCHOS FRONTALES**  
FRONT NIBS

ZM INX

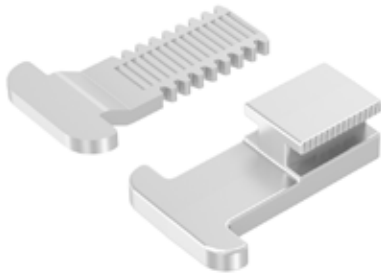

Los ganchos frontales en combinación con un cerradero permiten el cierre de los sistemas de ventanas corredera.

The front nibs in combination with a keeper allow the closing of the sliding window systems.

- Los ganchos son válidos para los cerreres de embutir TITÁN, FÉNIX y DRACO.
- El dentado especial permite la regulación micrométrica de los ganchos.
- Los ganchos se adaptan a diferentes series de ventanas correderas, ya sean tradicionales o perimetrales.

- The nibs are valid for the TITAN, FENIX and DRACO recessed handles.
- The special toothting allows micrometric adjustment of the nibs.
- The nibs can be adapted to different series of sliding windows, either traditional or perimeter.

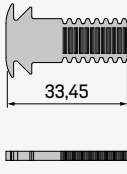
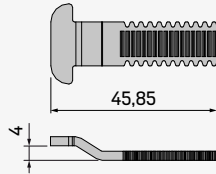
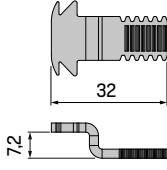
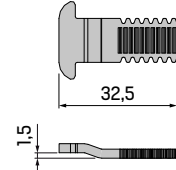
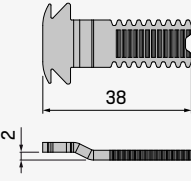
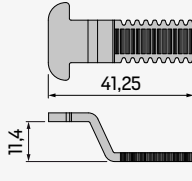
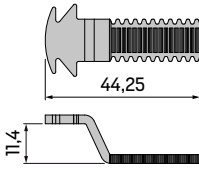
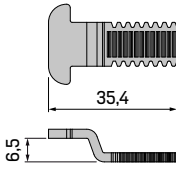
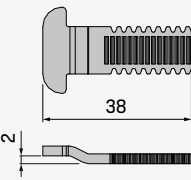
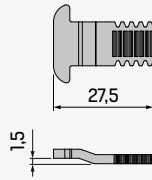
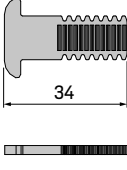
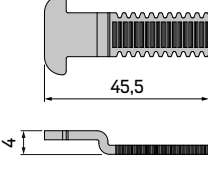
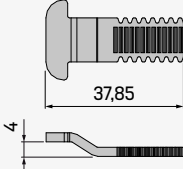
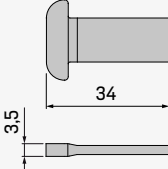
REFERENCIA REFERENCE	DIMENSIONES DIMENSIONS	MV	TITÁN	FÉNIX DRACO	REFERENCIA REFERENCE	DIMENSIONES DIMENSIONS	MV	TITÁN	FÉNIX DRACO
0503073		•	•	•	03153			•	•
0503148		•	•	•	03154			•	•
0503162		•	•	•	0503170			•	•
0503172		•	•	•	0503197			•	•
03150			•	•	0503207			•	•
03151			•	•	P0503153			•	•
03152			•	•	03019				•

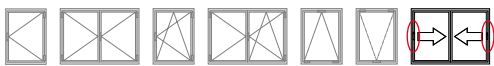

REFERENCIA REFERENCE	DIMENSIONES DIMENSIONS	MV	TITÁN	FÉNIX DRACO	REFERENCIA REFERENCE	DIMENSIONES DIMENSIONS	MV	TITÁN	FÉNIX DRACO
0301902				●	0503071				●
03007				●	0503072				●
03031				●	03078				●
0403048				●	0503083				●
03051				●	0503097				●
03069				●	0503098				●
03070				●	0503129				●

**MV:** Microventilación Micro-ventilation

**FÉNIX:** FÉNIX, FÉNIX MINI

**DRACO:** DRACO MAX, DRACO LINE

## GANCHOS VERTICALES

### VERTICAL NIBS



## GANCHOS VERTICALES

### VERTICAL NIBS

Los ganchos verticales en combinación con un cerradero permiten el cierre de los sistemas de ventanas corredera.





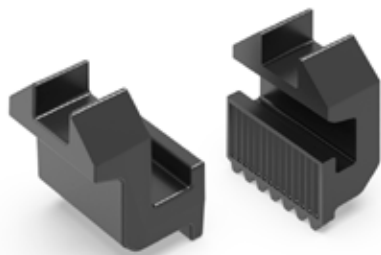

The vertical nibs in combination with a keeper allow the closing of the sliding window systems.

ZM

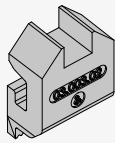

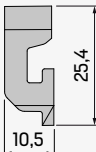
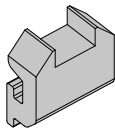
- Los ganchos son válidos para los cierres de embutir TITÁN, FÉNIX y DRACO.
- El dentado especial permite la regulación métrica de los ganchos.
- Los ganchos se adaptan a diferentes series de ventanas correderas, ya sean tradicionales o perimetrales.

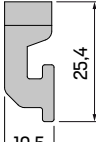
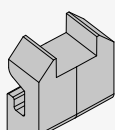
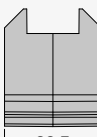
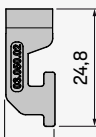
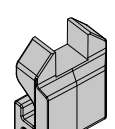
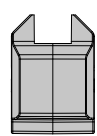
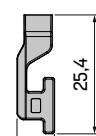
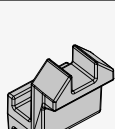
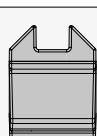
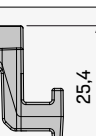
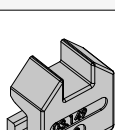
- The nibs are valid for the TITAN, FENIX and DRACO recessed handles.
- The special toothting allows metric adjustment of the nibs.
- The nibs can be adapted to different series of sliding windows, either traditional or perimeter.

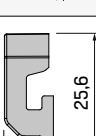
REFERENCIA REFERENCE	DIMENSIONES DIMENSIONS		MV	TITÁN	FÉNIX DRACO
03003	  				●
03032	  		●		●
0403050	  		●		●
0503085	  				●
0503132	  				●
0403149	  			●	●

**MV:** Microventilación Micro-ventilation

**FÉNIX:** FÉNIX, FÉNIX MINI

**DRACO:** DRACO MAX, DRACO LINE

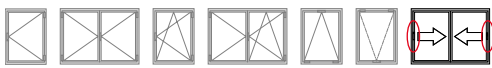

## CERRADEROS ACANALADOS GROOVED KEEPERS

The grooved keepers in combination with a nib allow the closing of the sliding window systems.

- There are two types of keepers available: grooved and overlapped.
- Adjusted to the frame to regulate with the closing nib.
- The nibs can be adapted to different series of sliding windows, either traditional or perimeter.

Los cerraderos acanalados en combinación con un gancho permiten el cierre de los sistemas de ventana corredera.

- Disponibles dos tipos de cerraderos: acanalados y superpuestos.
- Ajustados al marco para regular con el gancho de cierre.
- Los ganchos se adaptan a diferentes series de ventanas correderas, ya sean tradicionales o perimetrales.

## CERRADEROS ACANALADOS GROOVED KEEPERS

ZM

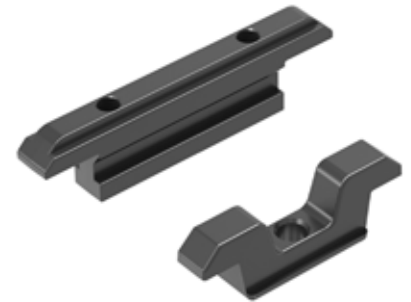

**REFERENCIA**  
REFERENCE

**DIMENSIONES**  
DIMENSIONS

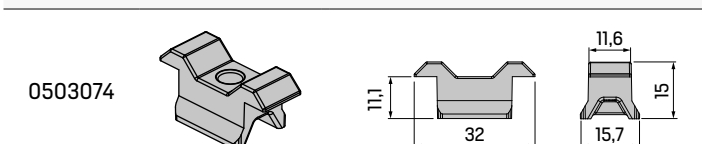
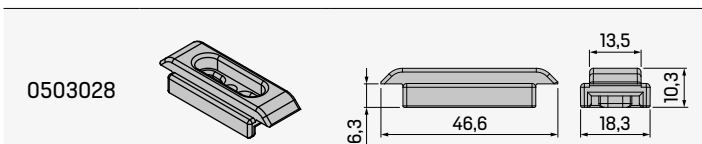
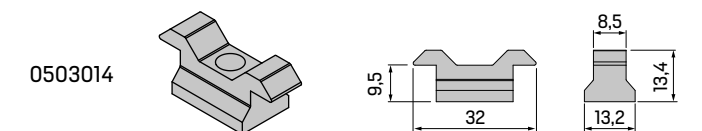
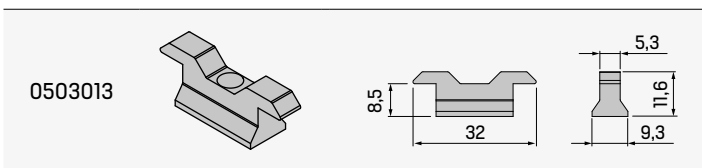
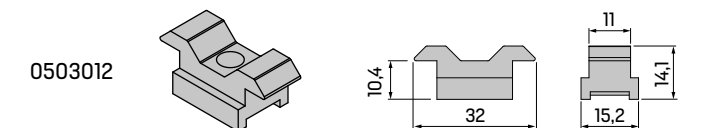
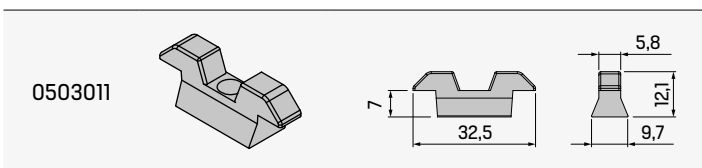
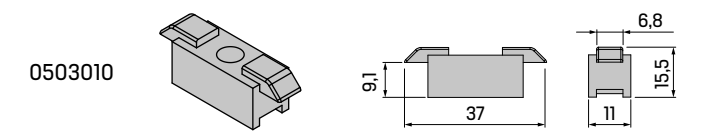
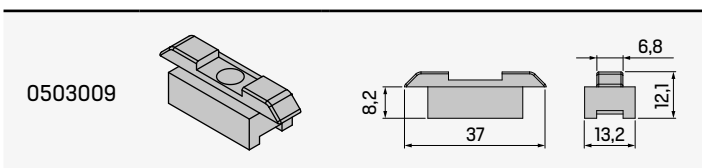

**REFERENCIA**  
REFERENCE

**DIMENSIONES**  
DIMENSIONS

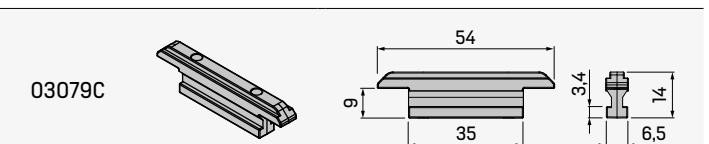
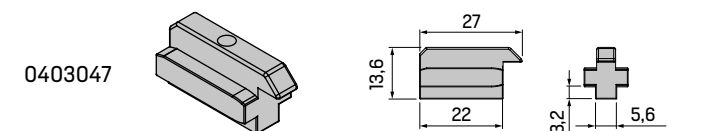
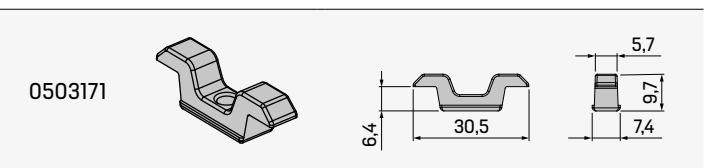
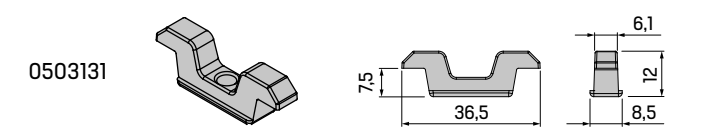
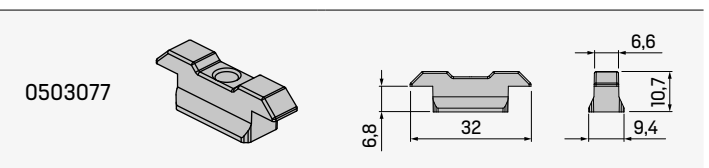
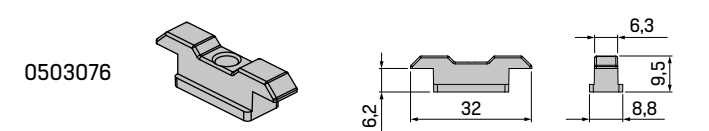
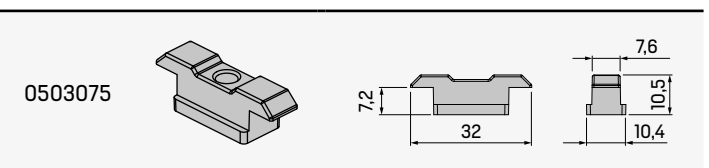

Las referencias incluyen tornillería  
References include screws

## CERRADEROS SUPERPUESTOS

### OVERLAPPED KEEPERS

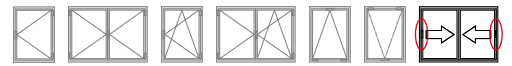

## CERRADEROS SUPERPUESTOS

### OVERLAPPED KEEPERS

Los cerraderos acanalados en combinación con un gancho permiten el cierre de los sistemas de ventana corredera.

The grooved keepers in combination with a nib allow the closing of the sliding window systems.

ZM



- Disponibles dos tipos de cerraderos: acanalados y superpuestos.
- Ajustados al marco para regular con el gancho de cierre.
- Los ganchos se adaptan a diferentes series de ventanas correderas, ya sean tradicionales o perimetrales.

- There are two types of keepers available: grooved and overlapped.
- Adjusted to the frame to regulate with the closing nib.
- The nibs can be adapted to different series of sliding windows, either traditional or perimeter.

REFERENCIA  
REFERENCE

DIMENSIONES  
DIMENSIONS

0503004		
0503086		
0503198		
0509106		
0403030		
09107		



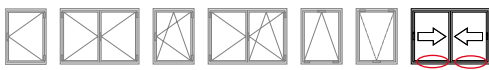

The LSPLUG adapter allows the use of the bogies that incorporate the lift & slide systems by adapting the profiles of lift systems as traditional sliding systems.

- High load capacity: 2 bogies can hold up to 300 / 400 kg per sash.
- The + 2.5 mm height adjustment is accessible and independent.
- The LSPLUG adapter is only suitable for profiles with a 22 mm groove.
- The reference 237009 includes centring shims for 22 mm grooves.
- Treated zamak components to withstand up to 480 hours in a saline mist chamber (UNE-EN 1670: 2007).

El adaptador LSPLUG permite utilizar los carros de los sistemas lift & slide adaptando los perfiles de sistemas elevables como sistemas de corredera tradicional.

- Alta capacidad de carga: 2 carros soportan hasta 300 / 400 kg por hoja.
- La regulación de + 2,5 mm en altura es accesible e independiente.
- El adaptador LSPLUG es solo válido para perfiles con canal de 22 mm.
- La ref. 237009 incluye calzos centradore para canales de 22 mm.
- Piezas de zamak tratadas para soportar hasta 480 horas en cámara de niebla salina (UNE-EN 1670: 2007).

**ADAPTADOR LSPLUG**  
LSPLUG ADAPTER

ZM AC



**Elevable LS400**  
LS400 Lift & Slide

237008

**Elevable LS200**  
LS200 Lift & Slide

237009

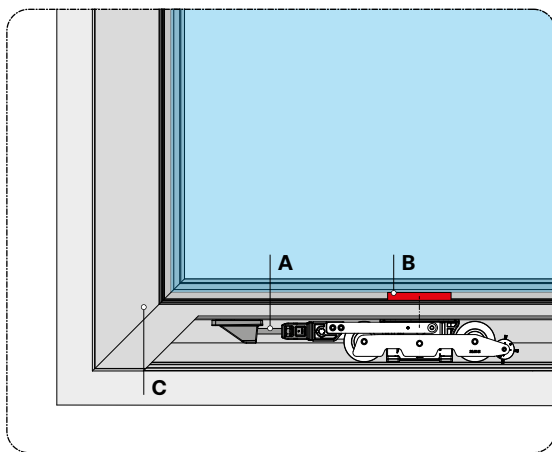

**A** Antes de fijar el dispositivo LSPLUG al perfil de hoja asegúrese de que el tornillo (A) se encuentra en tensión. Before fixing the LSPLUG device to the sash profile, make sure that the screw (A) is in tension.

**B** A partir de 200 kg de peso de hoja el calzo del vidrio se posicionará centrado con el carro. From 200 kg sash weight the glass shim will be positioned centrally with the bogie.

**C** Deje la distancia necesaria para evitar la interferencia de los tornillos con la escuadra. Leave space enough to avoid interference between the screws and the corner joint.

237009 LIFT & SLIDE LS200

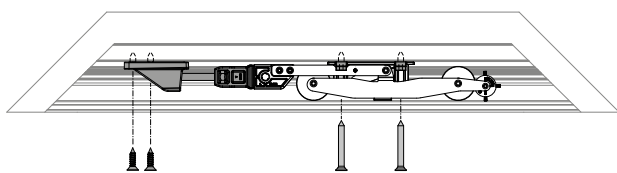

2370008 LIFT & SLIDE LS400

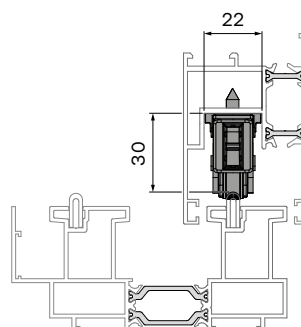
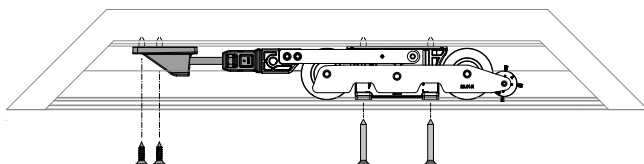

CANAL GROOVE LS200

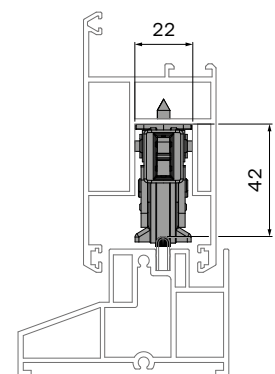

CANAL GROOVE LS400

■ REGULACIÓN ADJUSTMENT

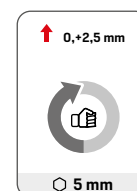
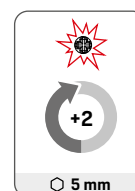
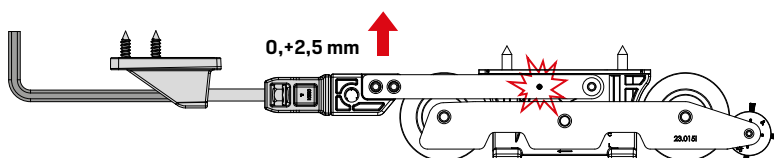

# hl bogies

Carros para altas cargas  
High load bogies

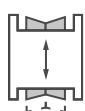

Regulación  $\pm 2,3$  mm  
 $\pm 2.3$  mm adjustment



200 kg por hoja  
200 kg per sash



2 ruedas  
Two wheels



Rodamientos de agujas  
Needle roller bearings

Los sistemas de ventana corredera están experimentando una evolución notable en cuanto a sus prestaciones y confort de uso. Esto implica perfiles con amplias roturas de puente térmico y vidrios de espesores considerables. Como resultado de todo ello, las dimensiones de los perfiles han crecido de forma considerable, haciendo evolucionar los herrajes encargados de darles vida.

Los carros **HL BOGIES** destacan principalmente por ser adaptables a todo tipo de sistemas de ventana corredera, permitir regulación en altura y soportar cargas de hasta 200 kg por hoja.

## » Adaptabilidad

Los carros están disponibles en 2 tamaños diferentes para permitir distinto ancho de rueda y ser usados en cualquier tipología de rail. La banda de rodadura está fabricada en POM [poliacetal] garantizando de esta forma su durabilidad y evitando el deterioro y desgaste de ruedas y rail.

## » Basculamiento

Los carros fallan principalmente debido al deterioro que sufren los rodamientos de las ruedas. Esto se debe al mayor esfuerzo que soportan unas ruedas en relación a las otras, es decir, el peso sobre cada rueda no está equilibrado.

El diseño de los carros HL se ha desarrollado con la premisa de equilibrar la carga que soporta cada rueda mediante un sistema de balancín y alargar así su vida útil.

## » Regulaciones efectivas

Si se requiere durante la instalación de la ventana, es posible realizar la regulación en altura de los carros.

Over recent years, the sliding window has undergone a notable evolution in specification and ease of use. This results in profiles with large thermal breaks and considerably thicker glass. As a result of this, the dimensions of the profiles have increased greatly, meaning that the hardware which brings them windows to life has also had to evolve.

The HL BOGIES stand out for the fact that they can adapt to all types of sliding window system, they are height-adjustable and can bear loads up to 200 kg per sash.

## » Adaptability

The bogies are available in 2 different sizes to allow distinct wheel widths and thus be usable in any rail system. The runner is manufactured in POM [polyoxomethylene] which guarantees its durability and avoids wear of the wheel and rail.

## » Tilting

Mainly, the bogies for sliding windows fail due to wear of the wheel bearings. This is due to the high forces that some wheels bear compared to others, i.e. the weight is not evenly distributed to all wheels.

The design of the HL bogies has been developed with the premise of balancing the load which each wheel bears via a novel rocker system which increases lifetime expectancy.

## » Effective adjustment

If required during the installation of the window, it is possible to adjust the height of the bogies directly.

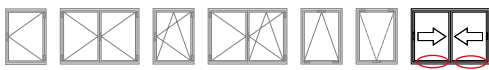

High load tilting bogies adaptable to different sliding window systems.

- The HL bogies can carry loads of up to 200 kg per sash and are height adjustable up to  $\pm 2.3$  mm.
- HL bogies are easily adaptable to different wheel geometries.
- Rocker arm system to balance the load on each wheel and extend its life.
- The bearings are needle roller bearings, which guarantees rolling quality at high loads.
- Treated zamak components to withstand up to 480 hours in a saline mist chamber (UNE-EN 1670: 2007).

Carros basculantes de altas cargas adaptables a diferentes sistemas de corredera.

- Los carros HL soportan cargas de hasta 200 kg por hoja y admiten regulación en altura de hasta  $\pm 2,3$  mm.
- Los carros HL son adaptables a distintas geometrías de rueda.
- Sistema de balancín que equilibra la carga de cada rueda y alarga su vida útil.
- Los rodamientos son de agujas, lo que garantiza la calidad de la rodadura con cargas elevadas.
- Piezas de zamak tratadas para soportar hasta 480 horas en cámara de niebla salina (UNE-EN 1670: 2007).

**CARRO HL 960101A**  
960101A BOGIE



960101A



REFERENCIA REFERENCE	GEOMETRÍA RAIL TRACK GEOMETRY	RUEDAS WHEELS	DIMENSIONES DE LOS CARROS BOGIE DIMENSIONS		REGULACIONES (mínima / máxima) ADJUSTMENTS (minimum / maximum)	
960101A	 4,3 / 14,3°	<b>POM</b>	 28,5 22,1 36,1	 126,3	 30,9	 28,6 33,2
960202B	 150°	<b>POM</b>	 20,9 13,9 24,7	 114,5	 26,8	 24,5 29,1
960203C	 150°	<b>POM</b>	 20,4 11,8 24,9	 115,6	 24,6	 22,3 26,9
960204D	 R25	<b>POM</b>	 19,3 99 21,9	 117,3	 40,6	 38,3 42,9
960305AX	 R25	<b>POM</b>	 33,3 40,9	 102,4	 21,9	 19,6 24,2
960402	 150°	<b>POM</b>	 20,4 20,5	 123,3	 22,8	 20,5 25,1
960406	 150°	<b>INX</b>	 20,4 20,5	 123,3	 22,8	 20,5 25,1
960405XA	 R25	<b>POM</b>	 22 20,5	 123,3	 24,8	 22,5 27,1

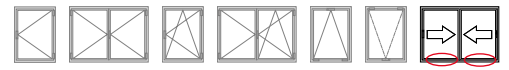

### CARROS PARA VENTANAS CORREDERAS

#### SLIDING WINDOW BOGIES



Los carros permiten a la hoja de la ventana corredera deslizarse de manera fluida y sin tirones sobre el carril de marco.

The bogies allow the sash of the sliding window to slide smoothly and without jerks on the frame rail.

- Regulación micrométrica que permite mover la hoja en sentido vertical.
- La regulación es posible con la hoja de la ventana ya instalada.
- Los carros disponen de una amplio rango de capacidad de carga.

- Micrometric adjustment that allows the sash to be moved vertically.
- The adjustment is possible with the window sash already installed.
- The bogies have a wide range of load capacity.

#### » CARACTERÍSTICAS CHARACTERISTICS



**PESO MÁXIMO POR HOJA**  
MAXIMUM WEIGHT PER SASH



**REGULACIÓN EN ALTURA**  
HEIGHT ADJUSTMENT



**CARRO CON 1 RUEDA**  
BOGIE WITH SINGLE WHEEL



**CARRO CON 2 RUEDAS**  
BOGIE WITH DOUBLE WHEEL

#### » RODAMIENTO BEARING



**RODAMIENTO DE BOLAS**  
BALL BEARING



**RODAMIENTO DE DOBLE BOLA**  
DOUBLE BALL BEARING



**RODAMIENTO DE AGUJAS**  
PIN BEARING



**RODAMIENTO SIMPLE**  
SINGLE BEARING

#### » GEOMETRÍA DE MARCO FRAME GEOMETRY



**EN FORMA DE V**  
IN A V SHAPE



**EN FORMA DE V PLANA**  
IN A FLAT V SHAPE



**EN FORMA DE U**  
IN A U SHAPE

#### » MATERIALES MATERIALS

**AL**

**ALUMINIO**  
ALUMINIUM

**ZM**

**ZAMAK**  
ZAMAK

**AC**

**ACERO**  
STEEL

**INX**

**ACERO INOXIDABLE**  
STAINLESS STEEL

**PA**

**POLIAMIDA**  
POLYAMIDE

**PE**

**POLIETILENO**  
POLYETHYLENE



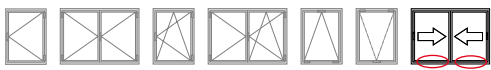

**PP**

**POLIPROPILENO**  
POLYPROPYLENE



**PA**



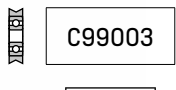

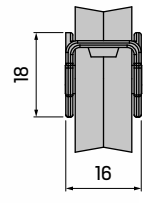
**CARRO C99003**  
C99003 BOGIE

 160°
  360 u.
  **MAX**
 30 kg
  **C99003**



**PA ZM**



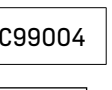

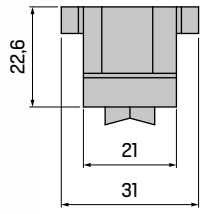

**CARRO C99004**  
C99004 BOGIE

 150°
  120 u.
  ± 2,5 mm
  **MAX**
 50 kg
  **C99004**



**PA**



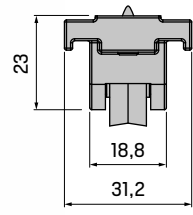

**CARRO C99005**  
C99005 BOGIE

 160°
  480 u.
  ± 1 mm
  **MAX**
 30 kg
  **C99005**



**AL**

**CARRO C99006**  
C99006 BOGIE

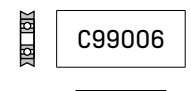
 166°
  340 u.
  **MAX**
 120 kg
  **C99006**

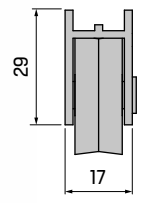

**AL**



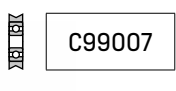

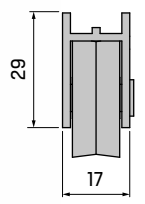
**CARRO C99007**  
C99007 BOGIE





 166°
  180 u.
  **MAX**
 200 kg
  **C99007**

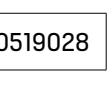

**PE**

**CARRO S2000**  
S2000 BOGIE

 150°
  250 u.
  ± 1,5 mm
  **MAX**
 20 kg
  **0519028**

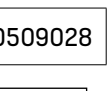
 250 u.
  ± 1,5 mm
  **MAX**
 40 kg
  **0509028**

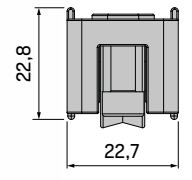

# CARROS PARA VENTANAS CORREDERAS

SLIDING WINDOW BOGIES

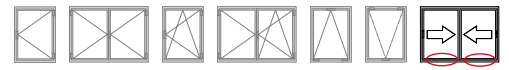

## CARRO S2000

S2000 BOGIE

ZM

0519023

50 kg ± 2,5 mm 150 u. 150°

0509023

100 kg ± 2,5 mm 150 u.

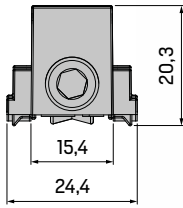

## CARRO S4200

S4200 BOGIE

ZM

A0519021

50 kg ± 2,5 mm 150 u. 150°

A0509021

100 kg ± 2,5 mm 150 u.

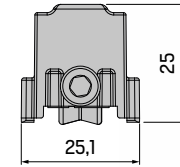

## CARRO S70P

S70P BOGIE

PA

0509040

50 kg ± 1 mm 250 u. 150°

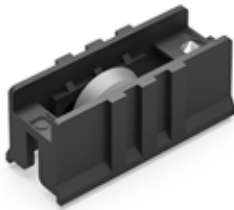
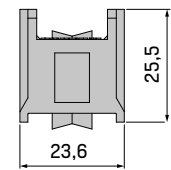

## CARRO S70 S92

S70 S92 BOGIE

PE

0509134

50 kg ± 2,5 mm 250 u. R2,2 mm

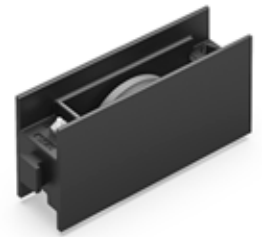
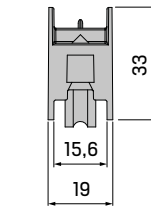

## CARRO S60P

S60P BOGIE

PP

0509039

40 kg ± 1 mm 250 u. 150°

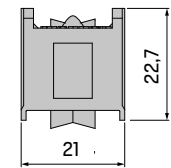

## CARRO S62

S62 BOGIE

PA

0509037

50 kg ± 1 mm 250 u. R2,2 mm

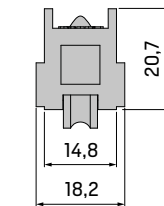

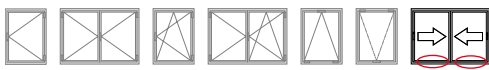

**ZM** **CARRO S5000 S2000 HR**  
S5000 S2000 HR BOGIE

150° 150 u. ± 2,5 mm 50 kg **MAX** **0509122**

150 u. ± 2,5 mm **MAX** **0509022**

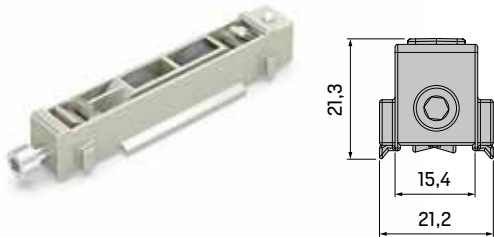

**ZM** **CARRO S5000 G90**  
S5000 G90 BOGIE

150° 150 u. ± 2,5 mm 50 kg **MAX** **0519022**

18,8 15,4 21,7



**PE** **CARRO S5000 S5200**  
S5000 S5200 BOGIE

150° 250 u. ± 1,5 mm 20 kg **MAX** **0509002**

250 u. ± 1,5 mm **MAX** **0509001**



**ZM** **CARRO S6500**  
S6500 BOGIE

R 5 mm 100 u. ± 2,5 mm 50 kg **MAX** **0509024**

38,4 24,6



**PA** **CARRO S6200**  
S6200 BOGIE

150° 250 u. ± 1,5 mm 40 kg **MAX** **0509109**

26,5 15,9



**PA** **CARRO S6200**  
S6200 BOGIE

150° 250 u. ± 1,5 mm 10 kg **MAX** **0519019**

250 u. ± 1,5 mm **MAX** **0519009**





## CONSIDERACIONES IMPORTANTES

### IMPORTANT CONSIDERATIONS

---

Bajo pedido desarrollamos para nuestros clientes todo el accesorio para sistemas de ventana corredera.

Si no ha encontrado lo que busca, póngase en contacto con nosotros y estudiaremos una solución adaptada a sus necesidades.

**[info@stac.es](mailto:info@stac.es)**

On request, we develop all accessories for sliding window systems for our customers.

If you have not found what are you looking for in this catalogue, please contact us and we will study a solution adapted to your needs.

**[info@stac.es](mailto:info@stac.es)**



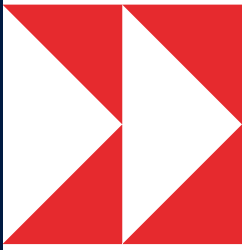

# 15

## **ESCUADRAS** CORNER JOINTS

- 308 **Escuadras mecanizadas**  
Machined corner joints
- 309 **Escuadras estampadas**  
Pressed corner joints
- 310 **Escuadras inyectadas de alineamiento**  
Die cast alignment corner joints
- 311 **Otras escuadras de alineamiento**  
Other alignment corner joints



## ESCUADRAS MECANIZADAS

### MACHINED CORNER JOINTS

## ESCUADRAS MECANIZADAS

### MACHINED CORNER JOINTS

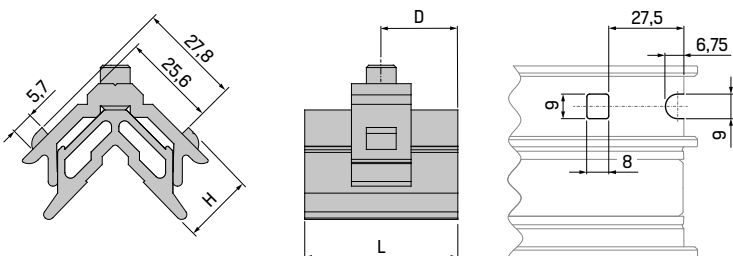

Escuadras mecanizadas para ensamblar perfiles de hoja y de marco.

- Escuadras mecanizadas de tetón es-triado y fresado que garantizan mejor precisión durante el apriete del inglete.
- Posicionamiento del elemento superior dependiendo del sistema y serie. Esto la convierte en versátil, ya que puede desplazarse sirviendo para otra serie distinta. Este desplazamiento permite absorber posibles irregularidades en el troquelado del perfil.

Machined corner joints for sash and frame profile assembly.

- Machined corner joints with grooved and milled pins that guarantee better precision when tightening the miter.
- Positioning of the upper element depending on the system and series. This makes it versatile, as it can be moved to serve a different series. This displacement allows the absorption of possible irregularities in the die-cutting of the profile.

#### » ESCUADRAS MECANIZADAS MACHINED CORNER JOINTS

REF.	H	L	D	
A02M1113C45	12	10,8	CENT.	300
02M2513C54	12	24	CENT.	250
02M1914C47	13,65	19	CENT.	400
02M1914D48	13,65	19	13,6	250
02M2014C50	13,65	19,4	CENT.	350
02M2214C06	13,65	21,6	CENT.	350
02M2614C09	13,65	24,9	CENT.	400
02M2614D40	13,65	24,9	10,7	250
02M2814D36	13,65	27,5	15	-
02M2914C32	13,65	28,6	CENT.	250
02M3014D35	13,65	29,8	12,5	250
02M3714D14	13,65	36,85	15	250
02M4114D21	13,65	41	15	250
02M4214D24	13,65	41,5	15	250
A02M4214C46	13,65	41,5	CENT.	300
02M4016D55	15,8	39,7	15	200
02M2516D38	15,8	24,7	16	350
02M1316C53	15,9	12,1	CENT.	250
02M3718D15	17,6	37	15	200
02M3818D18	17,6	37,2	16	250
02M4218D25	17,6	41,5	15	200
02M1120C43	19,2	10,8	CENT.	250
02M2020C49	19,2	19	CENT.	200
02M2620D31	19,2	24,7	16	200

REF.	H	L	D	
02M2520D39	19,2	25	16	250
02M4220C26	19,2	41,1	CENT.	-
A02M1724C52	23,8	16,3	CENT.	250
02M2626C10	25,2	24,7	CENT.	200
02M3826D19	25,2	37,5	16	125
02M1730C51	30	16,3	CENT.	250
02M1131C42	30,9	10,8	CENT.	250
02M1531C54	30,9	14,3	CENT.	250
02M2231C07	30,9	21,8	CENT.	175
02M2531D37	30,9	24,7	16	150
02M2631C11	30,9	24,7	CENT.	150
02M2632D30	30,9	24,7	16	125
02M3231C13	30,9	31,5	CENT.	150
02M3731D16	30,9	36	15	225
02M4231D27	30,9	41	15	175
02M2235D08	33,2	22	15	-
02M2636D12	35,2	25,6	11	125
02M3736D17	35,2	36	15	175
02M4236D28	35,2	40,8	15	175
02M0839C48	39,2	7,8	-	250
02M1141C44	39,2	10,8	CENT.	250
02M3840D20	39,2	37,5	15	150
02M4142C23	41,2	40,5	CENT.	250

CENT. = CENTRADO CENTRED

Pressed corner joints for sash and frame profile assembly.

- Blocking pressed corner joints with rounded tits that guarantee better precision when tightening the miter.
- Upper and lower elements cut to the same cutting width.

Escuadras estampadas para ensamblar perfiles de hoja y de marco.

- Escuadras de bloqueo estampadas con tetones redondos que garantizan mejor precisión durante el apriete del inglete.
- Elementos superior e inferior cortados al mismo ancho de corte.

**ESCUADRAS ESTAMPADAS**  
PRESSED CORNER JOINTS

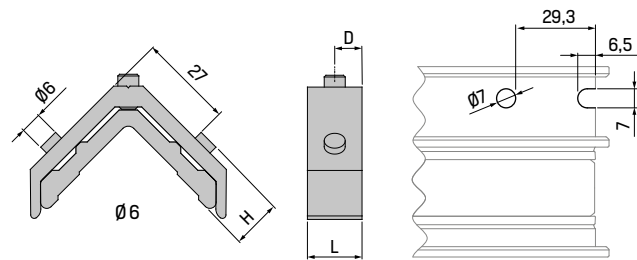
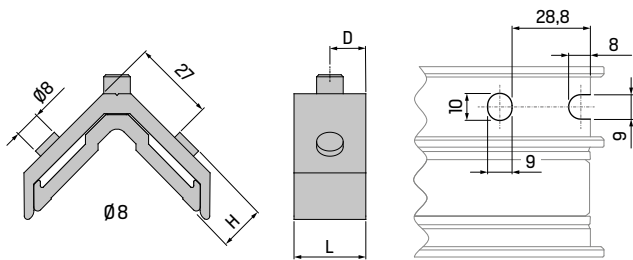

» ESCUADRAS ESTAMPADAS Ø8 Ø8 PRESSED CORNER JOINTS

REF.	H	L	D	
14221401	13,6	21,6	CENT.	250
14251403	13,6	24,7	CENT.	250
14271415	13,6	27	12	-
14291416	13,6	28,4	10,5	200
14301417	13,6	29,8	12,5	250
14311418	13,6	30,4	CENT.	250
14371402	13,6	36,6	15	250
14361427	13,6	37	CENT.	-
14411419	13,6	41	15	-
14421404	13,6	41,5	15	250
14371820	17,3	37	15	250
14371821	17,3	37	16	-
14421822	17,3	41,5	15	150
14412023	19,2	41	CENT.	-
14252624	25,2	24,7	CENT.	200
14372625	25,2	37	16	-

REF.	H	L	D	
14223105	29,2	21,6	CENT.	150
14253006	29,2	24,7	CENT.	150
14303029	29,2	30,5	CENT.	250
14323026	29,2	31,9	CENT.	200
14363028	29,2	35,9	CENT.	200
14373007	29,2	36,6	15	200
14413008	29,2	41	15	200
14223409	33,2	21,8	15	-
14233610	35,2	25,8	11	100
14363630	35,3	35,9	CENT.	175
14363611	35,3	36,6	15	-
14423612	35,3	41,5	15	150
14384013	39,2	37,5	15	150
14414214	41	40,5	CENT.	-
14454231	41,5	44,6	CENT.	100

CENT. = CENTRADO CENTRED

» ESCUADRAS ESTAMPADAS Ø6 Ø6 PRESSED CORNER JOINTS

REF.	H	L	D	
02E2514C39	14,1	25	CENT.	-
02E1614C29	14,2	15,6	CENT.	-
02E2014C33	14,2	19,2	CENT.	250
02E1118C42	17,5	11,5	CENT.	250
02E1218C02	17,5	12,3	CENT.	250

REF.	H	L	D	
02E1822C40	21,5	17,8	CENT.	-
02E4124D37	23,5	41	10	180
02E1836C41	35,5	17,4	CENT.	-
02E2638C38	37,5	26	CENT.	-

CENT. = CENTRADO CENTRED

## ESCUADRAS INYECTADAS DE ALINEAMIENTO

### DIE CAST ALIGNMENT CORNER JOINTS

#### ESCUADRAS INYECTADAS

##### DIE CAST CORNER JOINTS



Escuadras para el alineamiento de los perfiles de hoja y marco.

Corner joints for sash and frame profile alignment.

- Las escuadras de alineación tipo "fuji" tienen función de apriete.
- Las escuadras de expansión lateral están provistas de tornillo de anclaje.

- The "fuji" type alignment corner joints are for tightening.
- The side expansion corner joints are fitted with an anchor screw.

#### ESCUADRA TIPO BALA BULLET TYPE CORNER JOINT

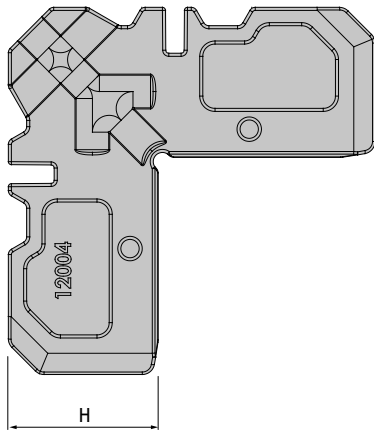

#### BALA BULLET

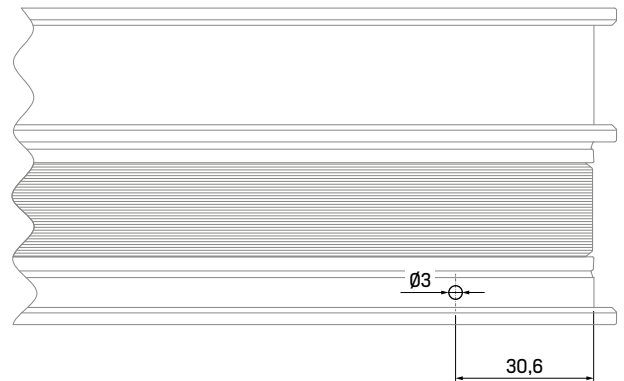
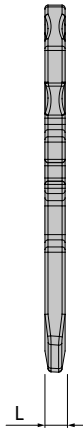

#### » ESCUADRAS INYECTADAS DIE CAST CORNER JOINTS

REF.	H	L	TIPO TYPE	
12002	15,4	9,2	BALA BULLET	300
12004	24,5	3,3	BALA BULLET	500
12001	30,2	9	BALA BULLET	200
12005	39,1	4	BALA BULLET	350

#### BALA BULLET

A12003	Ø3 x 8,8 mm de cabeza / of head	1000
--------	---------------------------------	------

Corner joints for sash and frame profile alignment.

- The brackets allow the perfect alignment of both the sash and the frame profiles.

Escuadras para el alineamiento de los perfiles de hoja y marco.

- Las escuadras permiten el perfecto alineamiento tanto de los perfiles de hoja como de marco.

**ESCUADRAS PLANAS**  
FLAT CORNER JOINTS

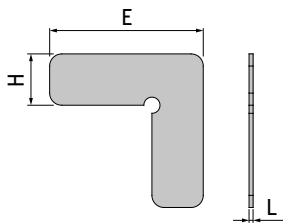

**ESCUADRAS EMBUTIDAS**  
RECESSED CORNER JOINTS

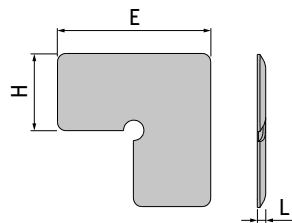

**ESCUADRAS PLEGADAS**  
FOLDED CORNER JOINTS

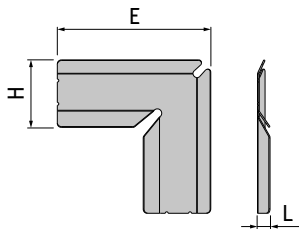

**OTRAS ESCUADRAS**  
OTHER CORNER JOINTS

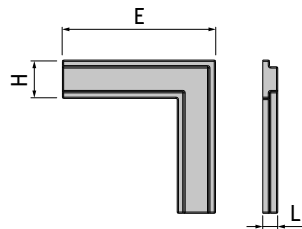

**ESCUADRAS PLANAS Y EMBUTIDAS**  
FLAT AND RECESSED CORNER JOINTS



**ESCUADRAS PLEGADAS**  
FOLDED CORNER JOINTS



» **ESCUADRAS PLANAS, EMBUTIDAS Y PLEGADAS** FLAT, RECESSED & FOLDED CORNER JOINTS

REF.	H	L	E	TIPO TYPE		
A99018	7,2	1,2	25,3	PLANA FLAT	Inx	3000
0599868	7,3	0,8	25,3	PLANA FLAT	Inx	-
A99019	12,7	1	38	PLANA FLAT	Inx	3000
A99020	14,7	1,1	39,2	EMBUTIDA RECESSED	Inx	1000
09999062	17	5,9	49,62	PLEGADA FOLDED	Inx	250
A99021	22,7	2,3	45,2	EMBUTIDA RECESSED	Inx	2000
09999061	23,14	4,3	52,59	PLEGADA FOLDED	Inx	250
99068	23,8	5	52,87	PLEGADA FOLDED	Inx	1500
99017	25,6	2,2	45,2	EMBUTIDA RECESSED	Inx	-
09999049	26,25	4,1	53,27	PLEGADA FOLDED	Inx	250

» **OTRAS ESCUADRAS** OTHER CORNER JOINTS

REF.	H	L	E	TIPO TYPE		
99027	6,25	2,45	25	ALINEAMIENTO ALIGNMENT	PA	5000
0599089	7,25	4,05	34,05	ALINEAMIENTO ALIGNMENT	ZM	350
0599145	8,8	3,8	29,7	ALINEAMIENTO ALIGNMENT	ZM	500
99137	13,7	5,1	65	ENSAMBLADA ASSEMBLED	AL	500
99127	13,7	22	65	ENSAMBLADA ASSEMBLED	AL	-
99126	13,7	25,2	65	ENSAMBLADA ASSEMBLED	AL	-
99004	17,3	3	50	SOLAPADA OVERLAPPED	PA	2000
09999055	29	3,05	59	SOLAPADA OVERLAPPED	PA	800

**OTRAS ESCUADRAS**  
OTHER CORNER JOINTS





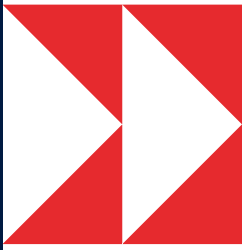

# 16

## MÁS PRODUCTOS MORE PRODUCTS

- 314 **Topes de zanca**  
Transom joints
- 315 **Inyección de plástico**  
Plastic injection moulding
- 316 **Fallebas de Canal Europeo**  
Euro Groove transmission rods
- 317 **Plantillas de mecanizado**  
Machining templates



## TOPES DE ZANCA TRANSOM JOINTS

### TOPES DE ZANCA TRANSOM JOINTS

04001

04005

04006

AL INX



Mecanismos que permiten el ensamblaje de las zancas de ventanas y puertas.

- Los topes de zanca son válidos para series de perfil con Canal Europeo.
- Los topes de zanca se suministran con tornillos.

Mechanisms that allow the assembly of window and door transoms.

- The transom joints are valid for Euro Groove profile series.
- The transom joints are supplied with screws.

#### » TOPES DE ZANCA TRANSOM JOINTS

REF.	DIMENSIONES DIMENSIONS		
04001			250 
04005			250 
04006			250 



Plastic injected products with top quality materials that complement other STAC products.

- Clip made of PA6 polyamide that allows the glazing bead to be attached.
- The deflectors are valid for 30 x 5 mm machining for profile series with Euro Groove.

Productos inyectados en plástico con materiales de máxima calidad que complementan otros productos STAC.

- Grapa fabricada en poliamida PA6 que permite la sujeción del junquillo.
- Los deflectores son válidos para cajeados de 30 x 5 mm para series de perfil con Canal Europeo.

» **TAPAS DE DESAGÜE** DRAINAGE CAPS

REF.	DIMENSIONES	DIMENSIONS	A	
09007*			20,7	1000
99025*			13,5	1000
09027			Ø12,5	1500

» **DEFLECTORES** DEFLECTORS

REF.	DIMENSIONES	DIMENSIONS	A	B	
09006*			33,2	30,9	1000
09016			31,1	27,7	1000
A09020			33,4	30,6	1000
P99024*			22,6	20,2	1000

\* Referencias disponibles en distintos colores. Consulte con su agente comercial.

\* References available in different colours. Consult with your sales agent.

**GRAPA PARA JUNQUILLO**  
GLAZING BEAD CLIP

PA

A99009

4000

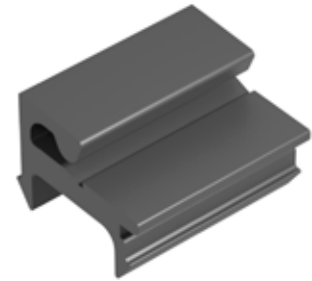

**TAPAS DE DESAGÜE**  
DRAINAGE CAPS

PA



**DEFLECTORES**  
DEFLECTORS

PA

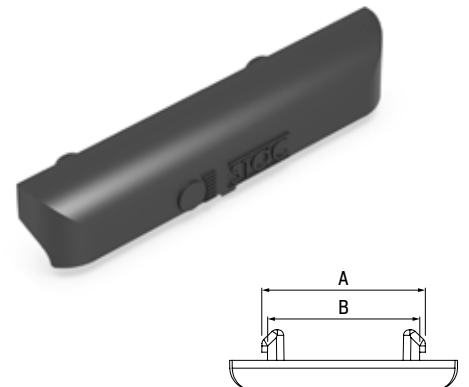

## FALLEBAS DE TRANSMISIÓN PARA CANAL EUROPEO

EURO GROOVE TRANSMISSION RODS

### FALLEBA DE TRANSMISIÓN DE POLIAMIDA

POLYAMIDE TRANSMISSION ROD

059233



250 m



PA

TFS 02

TFS 04

TFS 05

TFS 06

TFS 08

Fallebas de transmisión para series de perfil de Canal Europeo.

- Fallebas disponible en 2 materiales: Poliamida y PVC.
- Las fallebas están diseñadas de tal forma que permiten un deslizamiento suave a través del canal del perfil.
- Mecanizado y corte a medida a través de troqueladoras de fallebas STAC.
- Las fallebas de transmisión permiten instalar tantos puntos de cierre adicionales como se requiera y en el lugar deseado.
- No se recomienda instalar la falleba de transmisión de PVC con los siguientes remaches: ref. 0511088 / 0517002.

Transmission rods for Euro Groove profile series.

- Transmission rod available in 2 materials: Polyamide and PVC.
- The rods are designed in such a way that they allow a smooth slide through the profile groove.
- Machining and cut to size through STAC operating rod machines.
- The transmission rods allow the installation of as many additional locking points as required and at the desired location.
- It is not recommended to install the PVC transmission rod with the following rivets: ref. 0511088 / 0517002.

### FALLEBA DE TRANSMISIÓN DE PVC

PVC TRANSMISSION ROD

059238



250 m



PVC

TFS 02

TFS 04

TFS 05

TFS 06

TFS 08

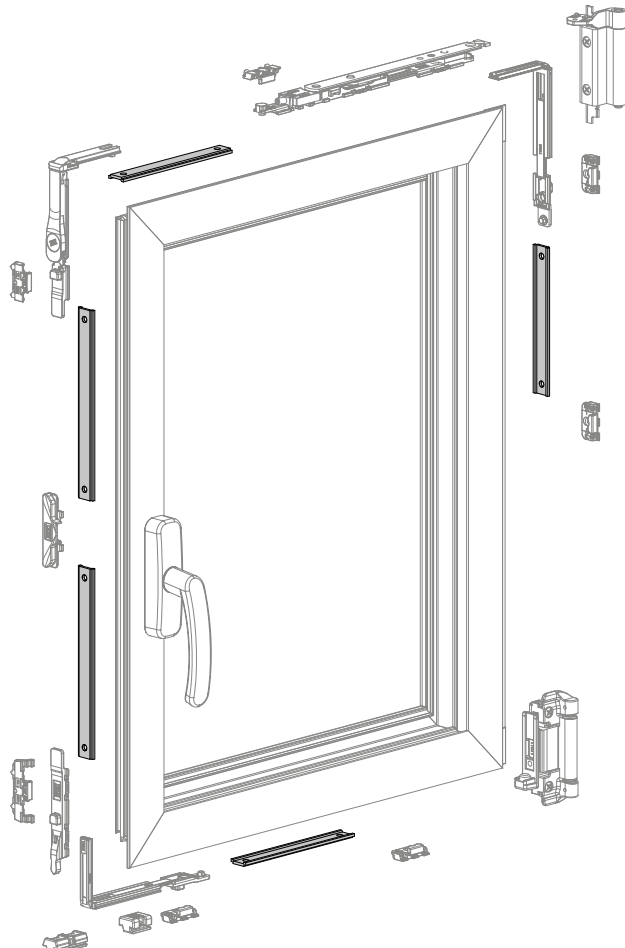
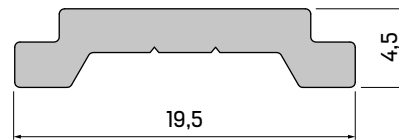

STAC hardware machining templates for carpentry workshops.

- The same template can be used for multiple machining sizes.
- By using the templates in the aluminium copying machines, the machining is done directly by means of feeler gauges.
- The templates are made of stainless steel AISI 304.

Plantillas de mecanizado de herraje STAC para talleres de carpintería.

- Con una misma plantilla se tiene acceso a múltiples medidas de mecanizado.
- A través del uso de las plantillas en las copadoras el mecanizado se hace de forma directa a través de palpadores.
- Las plantillas se han fabricado en acero inoxidable AISI 304.

**PLANTILLAS DE MECANIZADO**  
MACHINING TEMPLATES

STC-MC-00 AA

1

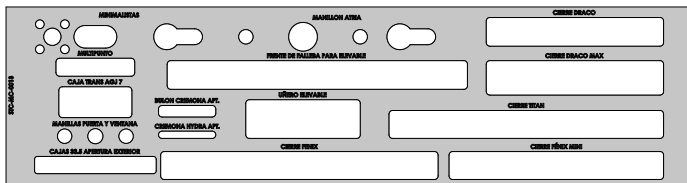

PRODUCTOS PRODUCTS	STC-MC-0013	STC-MC-0014	STC-MC-0015	STC-MC-0016	STC-MC-0017	STC-MC-0018
<b>MANILLAS MINIMALISTAS</b> MINIMALIST HANDLES	●					●
<b>MANILLAS PARA VENTANA Y PUERTA</b> WINDOW & DOOR HANDLES	●			●		
<b>UÑERO Y MANILLÓN ATRIA</b> ATRIA FINGER & PULL HANDLE	●	●			●	
<b>FALLEBAS DE TRANSMISIÓN</b> DRIVE GEARS	●	●			●	
<b>CAJAS DE TRANSMISIÓN 7 mm</b> 7 mm GEARBOXES	●	●				●
<b>CAJAS DE TRANSMISIÓN 33,5 mm</b> 33,5 mm GEARBOXES	●	●				
<b>CIERRES DE EMBUTIR TITÁN</b> TITAN RECESSED HANDLE	●					●
<b>CIERRES DE EMBUTIR FÉNIX</b> FENIX RECESSED HANDLE	●			●		
<b>CIERRES DE EMBUTIR FÉNIX MINI</b> FENIX MINI RECESSED HANDLE	●		●			
<b>CIERRES DE EMBUTIR DRACO</b> DRACO RECESSED HANDLE	●		●			
<b>CREMONA HYDRA (APERTURA EXTERIOR)</b> HYDRA CREMONE (OUTWARD OPENING)	●	●		●		
<b>CIERRES MULTIPUNTO</b> MULTIPOINT LOCKS		●		●		
<b>MANILLA OCULTA</b> CONCEALED HANDLE		●				●



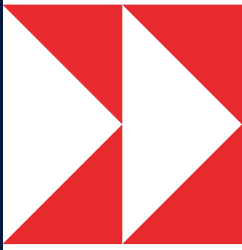

# 17

## MAQUINARIA MACHINERY

- 320 **Máquina troqueladora TFS01**  
TFS01 die-cutting machine
- 321 **Máquina troqueladora TFS02**  
TFS02 die-cutting machine
- 322 **Máquina troqueladora TFS04**  
TFS04 die-cutting machine
- 322 **Máquina troqueladora TFS05**  
TFS05 die-cutting machine
- 323 **Máquina troqueladora TFS06**  
TFS06 die-cutting machine
- 324 **Máquina troqueladora TFS08**  
TFS08 die-cutting machine
- 326 **Banco de herraje BHS01**  
BHS01 hardware assembly centre



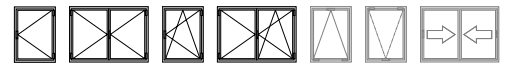

**MÁQUINA TROQUELADORA TFS01**  
TFS01 DIE-CUTTING MACHINE

4444



**MÁQUINA TROQUELADORA TFS01 C16**  
TFS01 C16 DIE-CUTTING MACHINE

4444C16



Máquina manual que permite realizar los diferentes tipos de mecanizado y remachados de las fallebas para las ventanas practicables y oscilobatientes.

- La máquina TFS-01 dispone de un troquel neumático con cinco entradas.
- La máquina TFS-01 se entrega con una regla graduada con topes de descuento predeterminados para las fallebas de transmisión necesarias en el montaje del sistema oscilobatiente.

**TFS-01 C16**

- Máquina manual ideal para pequeñas producciones.
- Permite realizar todos los mecanizados necesarios para el montaje del sistema oscilobatiente C16 y el remachado de los puntos de cierre.
- La máquina se suministrar con devanadora de fallebas.

Manual machine that allows to carry out the different machining and riveting of the transmission rods for side-hung and tilt & turn windows.

- The TFS-01 machine has a pneumatic punch tool with five inputs.
- The TFS-01 machine is delivered with a graduated ruler with pre-determined discount stops for the transmission rods required for the installation of the tilt & turn system.

**TFS-01 C16**

- Manual machine ideal for small production runs.
- It allows to carry out all the necessary machining for the assembly of the C16 tilt & turn system and the riveting of the locking points.
- The machine is supplied with transmission rod reel holder.

■ MECANIZADOS MACHININGS TFS01 C16

REMACHADO RIVETING



PUNZONADO PUNCHING Ø6 mm

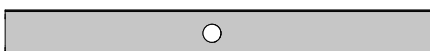

CORTE Y PUNZONADO CUT AND PUNCHING Ø6 mm



RANURADO GROOVED

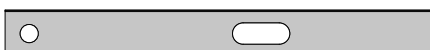

■ PUNZONADO Ø6 mm Y TROQUELADO LATERAL  
PUNCHING Ø6 mm AND SIDE DIE-CUTTING

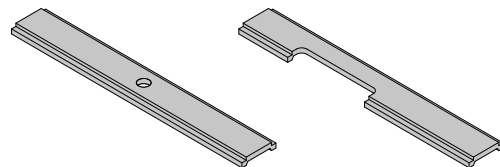

■ CORTE Y PUNZONADO Ø6 mm / Ø8 mm  
CUT AND PUNCHING Ø6 mm / Ø8 mm

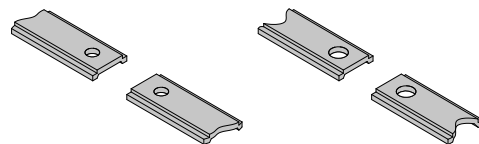

■ REMACHADOS: REMACHE DE TRANSMISIÓN Y PUNTO DE CIERRE DE REMACHE  
RIVETINGS: TRANSMISSION RIVET AND RIVET LOCKING POINT

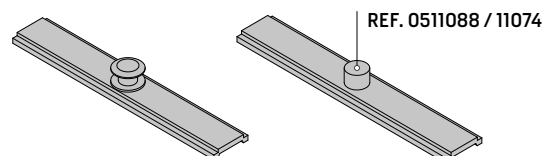

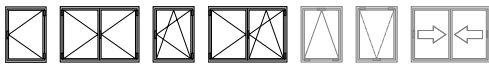

Automatic machine that allows to carry out the different machining and riveting of the transmission rods for side-hung and tilt & turn windows.

- The TFS-02 die-cutting machine has automatic feeding of polyamide plates.
- By entering the window sash dimensions and the friction stay, it automatically cuts the plates.
- The TFS-02 machine allows for automatic mode the placement of rivet and transmission locking points.
- The TFS-02 machine has a manual operation mode.
- The TFS-02 machine allows multiple types of machining as well as the addition of riveting and punching of  $\varnothing 6$  and  $\varnothing 8$  mm.

Máquina automática que permite realizar los diferentes tipos de mecanizado y remachados de las fallebas para las ventanas practicables y oscilobatientes.

- La máquina dispone de alimentación automática de pletinas de poliamida.
- Introduciendo las medidas de la hoja de la ventana y el compás, realiza automáticamente el corte de las pletinas.
- La máquina permite realizar de modo automático la colocación de puntos cierre de remache y de transmisión.
- La máquina TFS-02 dispone de modo de funcionamiento manual.
- Permite realizar múltiples tipos de mecanizados así como añadir puntos de cierre remachados y punzonados de  $\varnothing 6$  y  $\varnothing 8$  mm.

**MÁQUINA TROQUELADORA TFS02**  
TFS02 DIE-CUTTING MACHINE



4445



**SOPORTE DEVANADORA DE BOBINA DE FALLEBA**  
TRANSMISSION ROD REEL HOLDER



4446



■ **PUNZONADO Y PUNZONADO  $\varnothing 6$  mm**  
PUNCHING AND PUNCHING  $\varnothing 6$  mm

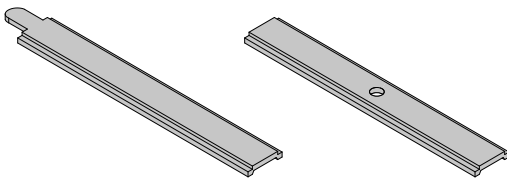

■ **CORTE Y PUNZONADO  $\varnothing 6$  mm /  $\varnothing 8$  mm**  
CUT AND PUNCHING  $\varnothing 6$  mm /  $\varnothing 8$  mm

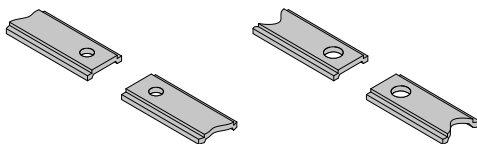

■ **REMACHADO DE PUNTO DE CIERRE DE REMACHE**  
RIVET LOCKING POINT RIVETING

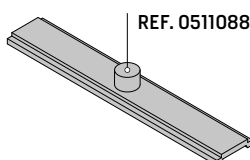

## MÁQUINA TROQUELADORA TFS04 / TFS05

TFS01 DIE-CUTTING MACHINE

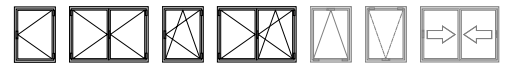

### MÁQUINA TROQUELADORA TFS04

TFS04 DIE-CUTTING MACHINE

4448



Máquina semiautomática que permite realizar los diferentes tipos de mecanizado y remachados de las fallebas para las ventanas practicables y oscilobatientes.

- Las máquinas permiten mecanizar las fallebas para Canal Europeo (TFS04 / TFS05) y Canal 16 mm (TFS05).
- Permiten realizar el corte y punzonado de Ø6 mm así como el troquelado y remachado.
- Las máquinas TFS facilitan la actividad del técnico proporcionando mayor eficiencia y rapidez en su trabajo ya que realiza menos cortes.
- Apenas ocupa espacio en el taller: 240 x 250 x 365 mm.

Semi-automatic machine that allows to carry out the different machining and riveting of the transmission rods for side-hung and tilt & turn windows.

- The machines allow the machining of the rods for Euro Groove (TFS04 / TFS05) and 16 mm Groove (TFS05).
- They allow for the cutting and punching of Ø6 mm as well as punching and riveting.
- The TFS machines facilitate the activity of the technician providing greater efficiency and speed in their work as they make fewer cuts.
- It barely takes up space in the workshop: 240 x 250 x 365 mm.

### MÁQUINA TROQUELADORA TFS05

TFS05 DIE-CUTTING MACHINE

4449



#### ■ CORTE Y PUNZONADO CUT AND PUNCHING Ø6 mm



#### ■ TROQUELADO STAMPING



#### ■ REMACHADO RIVETING REF. 0517002

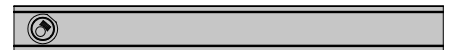

#### ■ RANURADO GROOVED



### SOPORTE DEVANADORA DE BOBINA DE FALLEBA

TRANSMISSION ROD REEL HOLDER

4450





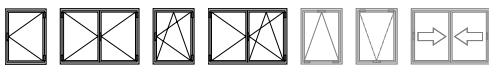

Automatic machine that allows to carry out the different machining and riveting of the transmission rods for aluminium and C16 aluminium side-hung and tilt & turn windows.

Máquina automática que permite realizar los diferentes tipos de mecanizado y remachados de las fallebas para las ventanas practicables y oscilobatientes de aluminio y aluminio C16.

- Multi-plate: the machine mechanizes the transmission rods for Euro Groove, and 16 mm Groove.
- It allows to perform the cutting and punching of  $\varnothing 6$  mm as well as the punching and riveting at the end of the Euro Groove plate.
- STAC working system: less assembly time, less cuts, more versatility equal to more productivity.
- The machine can be programmed according to the customer's needs.
- The machine is supplied with transmission rod reel holder.

- Multiplatinas: la máquina mecaniza las fallebas de transmisión para Canal Europeo y Canal 16 mm.
- Permite realizar el corte y punzonado de  $\varnothing 6$  mm así como el troquelado y remachado en la punta de la pletina de Canal Europeo.
- Sistema de trabajo STAC: menos tiempo de montaje, menos cortes, más versatilidad igual a mayor productividad.
- La máquina permite su programación a medida del cliente.
- La máquina se suministra con devanadora de fallebas.

**MÁQUINA TROQUELADORA TFS06**  
TFS06 DIE-CUTTING MACHINE



4451



**STAC CE**

**CANAL EUROPEO EURO GROOVE**

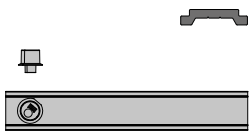

**MODO AUTOMÁTICO AUTOMATIC MODE**

**Carga de remache 0517002 y operación de remachado**  
Rivet loading 0517002 and riveting operation



**MODO AUTOMÁTICO AUTOMATIC MODE**

**Troquelado en punta**  
Pointed die-cutting

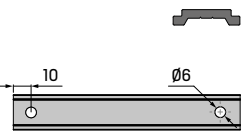

**MODO AUTOMÁTICO AUTOMATIC MODE**

**Corte y punzonado  $\varnothing 6$  mm**  
Cutting and punching  $\varnothing 6$  mm

**STAC 16**

**GORGE 16 mm CANAL 16 mm**

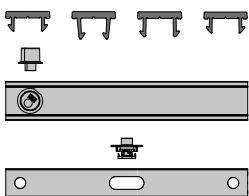

**MODO AUTOMÁTICO AUTOMATIC MODE**

**Carga de remache 0517002 y operación de remachado**  
Rivet loading 0517002 and riveting operation

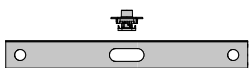

**Ranurado**  
Grooved

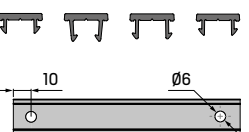

**MODO AUTOMÁTICO AUTOMATIC MODE**

**Corte y punzonado  $\varnothing 6$  mm**  
Cutting and punching  $\varnothing 6$  mm

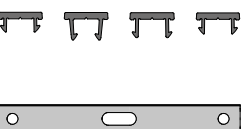

**MODO AUTOMÁTICO AUTOMATIC MODE**

**Corte y punzonado  $\varnothing 6$  mm / Ranurado**  
Cutting and punching  $\varnothing 6$  mm / Grooved

## MÁQUINA TROQUELADORA TFS08

TFS08 DIE-CUTTING MACHINE

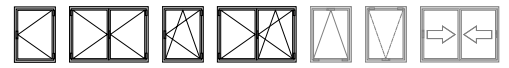

## MÁQUINA TROQUELADORA TFS08

TFS08 DIE-CUTTING MACHINE

TFS08-CE-N00



## REGLA TELESCÓPICA TFS08

TFS08 TELESCOPIC RULER

TFS08-BA-00

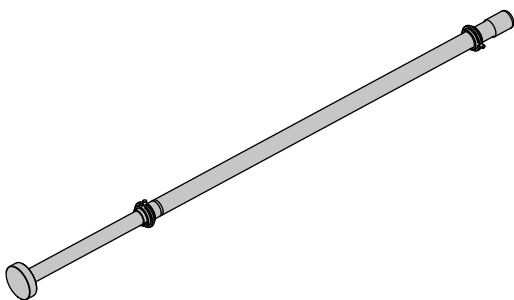

## FALLEBAS DE TRANSMISIÓN

TRANSMISSION RODS

059233

059238



250 m



PA PVC



Máquina manual que permite realizar los diferentes tipos de mecanizado y remachados de las fallebas para las ventanas practicables y oscilobatientes.

- Sistema de corte único, sin operaciones aritméticas y descuentos directos a partir de la ventana.
- Máquina compatible con las configuraciones más habituales de cremona y caja de transmisión.
- Permiten realizar el corte y punzonado de Ø6 mm.
- Dispone de regla telescópica que permite tomar las medidas directamente sobre la ventana.
- Plantillas de descuentos que junto con la regla telescópica permiten obtener los descuentos de forma directa.

En el catálogo técnico TFS08 se describen detalladamente todas las configuraciones posibles para esta máquina.

Manual machine that allows to carry out the different machining and riveting of the transmission rods for side-hung and tilt & turn windows.

- Unique cutting system, no arithmetic operations and direct discounts from the window.
- Machine compatible with the most common cremone and gearbox configurations.
- They allow for the cutting and punching of Ø6 mm.
- It has a telescopic ruler that allows measurements to be taken directly on the window.
- Discount templates which, together with the telescopic ruler, make it possible to obtain discounts directly.

All possible configurations for this machine are described in detail in the TFS08 technical catalogue.

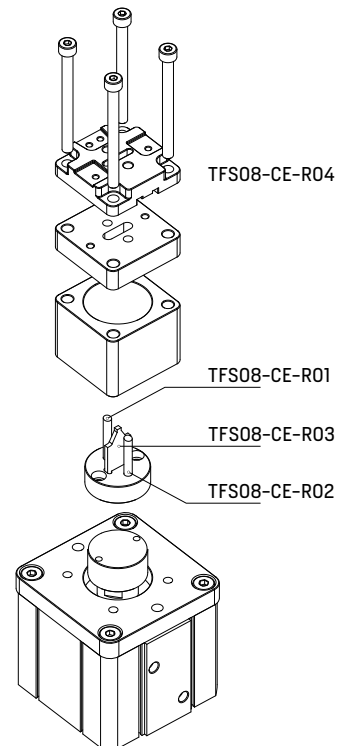

REF. DESCRIPCIÓN DESCRIPTION

TFS08-CE-R01 PUNZÓN CIRCULAR PARA PERFORADO CILÍNDRICO (52 mm)  
CIRCULAR CYLINDER DRILLING PUNCH (52 mm)

TFS08-CE-R02 PUNZÓN CIRCULAR PARA PERFORADO CILÍNDRICO (50 mm)  
CIRCULAR CYLINDER DRILLING PUNCH (50 mm)

TFS08-CE-R03 CUCHILLA PARA REALIZAR EL CORTE TERMINAL DE FALLEBA  
BLADE TO PERFORM THE TRANSMISSION ROD END CUT

TFS08-CE-R04 MATRIZ DE CORTE  
CUTTING MATRIX

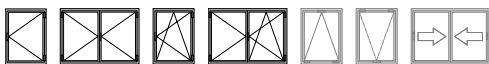

**PLANTILLAS DE DESCUENTOS TFS08**  
TFS08 DISCOUNT TEMPLATES

REFERENCIA REFERENCE	PLANTILLA DE DESCUENTO DISCOUNT TEMPLATES
TFS08-P01-00	<b>COMPÁS</b> FRICTION STAY
TFS08-P02-00	<b>CREMONA PARA APERTURA PRACTICABLE</b> CREMONE FOR SIDE-HUNG OPENING
TFS08-P03-00	<b>CREMONA PARA APERTURA OSCIOBATIENTE</b> CREMONE FOR TILT & TURN OPENING
TFS08-P04-00	<b>MANILLA PARA APERTURA PRACTICABLE</b> HANDLE FOR SIDE-HUNG OPENING
TFS08-P05-00	<b>MANILLA PARA APERTURA OSCIOBATIENTE</b> HANDLE FOR TILT & TURN OPENING

TFS  
08

TFS08-P01-00

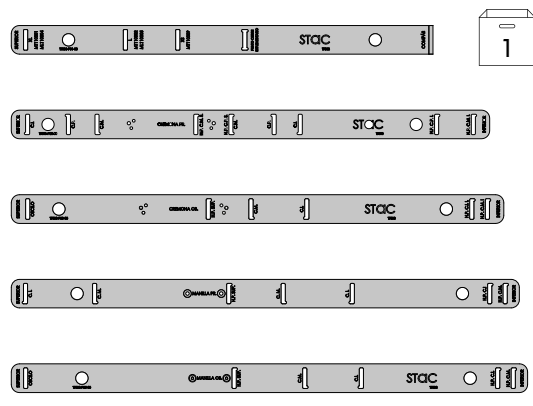

La máquina troqueladora TFS08 dispone de 3 límites para los descuentos  
The TFS08 die-cutting machine has 3 limits for discounts

- 1 **Permite obtener las fallebas para configuraciones estándar**  
Allows to obtain the rods for standard configurations
- 2 **Permite obtener las fallebas para configuraciones con microventilación**  
Allows to obtain the rods for micro-ventilation configurations
- 3 **Permite obtener las fallebas para configuraciones con punto de cierre intermedio**  
Allows to obtain the rods for configurations with an intermediate locking point

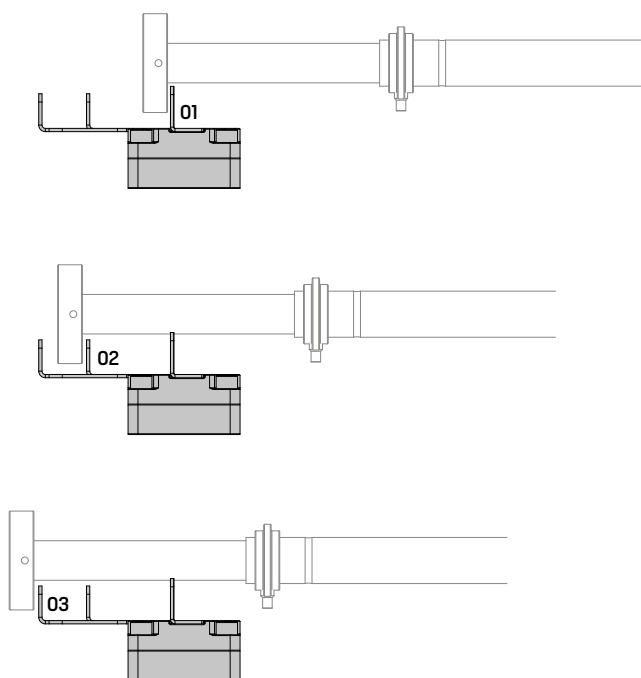

**SOPORTE TFS08**  
TFS08 SUPPORT

TFS  
08

TFS08-SOP-00

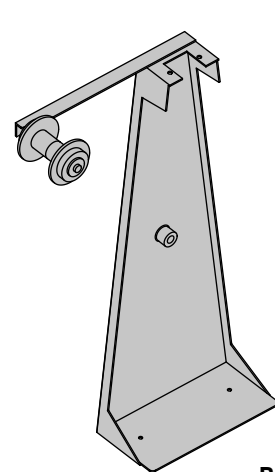

**PEDAL TFS08**  
TFS08 FOOT PEDAL

TFS  
08

TFS08-PED-00

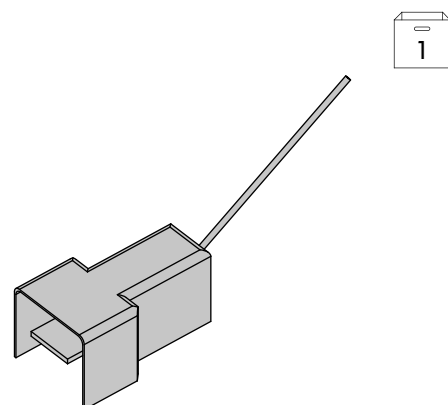

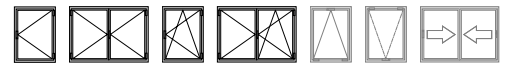

**BANCO DE HERRAJE BHS01**  
BHS01 HARDWARE ASSEMBLY CENTRE

BHS01



Banco de herraje destinado a realizar el mecanizado, atornillado, corte y montaje de los herrajes STAC, STAC16 y PVC.

- Máquina de bancada basculante neumática y ergonómica.
- Dispone de centradores automáticos de hojas de ventana para el mecanizado de la cremona.
- Dispone de topes regulables de fresado / taladrado de cremona (cota fija o variables) y corte de transmisiones (según los sistemas de herraje).
- El banco está provisto de atornillador con carga automática de tornillos.
- El banco posee una capacidad para albergar marcos de hoja o ventana con un alto máximo de 3000 x 3000 mm aprox. y un mínimo de 300 x 300 mm con espesor máximo de 100 mm y una sección variable entre 25 y 100 mm.

Hardware bench for machining, screwing, cutting and assembly of STAC, STAC16 and PVC hardware.

- Pneumatic and ergonomic tilting bench machine.
- It has automatic window sash centering devices for the machining of the cremone.
- It has adjustable stops for milling / drilling cremone (fixed or variable height) and transmission cutting (depending on the hardware system).
- The bench is equipped with a screwdriver with automatic screw loading.
- The bench can accommodate sash or window frames with a maximum height of approx. 3000 x 3000 mm and a minimum of 300 x 300 mm with a maximum thickness of 100 mm and a variable section between 25 and 100 mm.

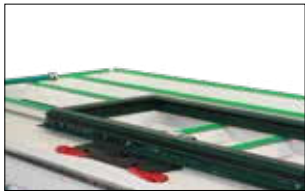

**MESA DE TRABAJO**  
WORK BENCH



**UNIDAD DE FRESADO INFERIOR PARA CREMONA**  
LOWER MILLING UNIT FOR CREMONE

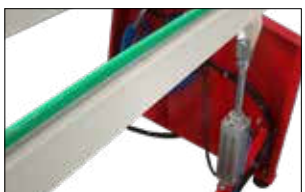

**CILINDROS BASCULANTES**  
TILTING CYLINDERS



**CIZALLA PARA PLETINA DE POLIAMIDA**  
POLYAMIDE ROD SHEAR



**CARGADOR DE TORNILLOS AUTOMÁTICO**  
AUTOMATIC SCREW LOADER



**SISTEMA DE TOPES PARA COTA FIJA**  
STOP SYSTEM FOR FIXED NUMBER



**MÓDULO DE ATORNILLADO**  
SCREWING MODULE



**CUADRO DE MANDOS**  
CONTROL PANEL



The machinery developed by STAC is designed to be used exclusively with STAC products. If used with any other type of hardware, STAC cannot be held responsible for its operation.

In the specific case of the TFS transmission rod die cutting machines, STAC cannot be held responsible for their operation with any other type of plate than the polyamide rod plates for the Euro Groove and 16 mm Groove **STAC MID**.

La maquinaria STAC está diseñada para ser utilizada única y exclusivamente con productos STAC. Si se utiliza con cualquier otro tipo de herraje, STAC no se hace responsable de su funcionamiento.

En el caso concreto de las máquinas troqueladoras de fallebas TFS, STAC no se hace responsable de su funcionamiento con otras pletinas que no sean las pletinas de falleba de poliamida para Canal Europeo y Canal 16 mm **STAC MID**.



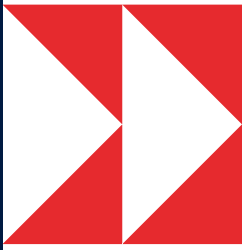

# 18 STAC 16

- 330 **Canal 16 mm**  
16 mm groove
- 332 **Bisagras**  
Hinges
- 334 **Apertura practicable**  
Side-hung opening
- 342 **Apertura oscilobatiente**  
Tilt & turn opening
- 346 **Ángulo de reenvío suplementario**  
Supplementary corner drive
- 347 **Compás suplementario**  
Supplementary friction stay
- 347 **Compases limitadores**  
Limiting friction stays
- 350 **Puntos de cierre**  
Locking points
- 352 **Microventilación**  
Micro-ventilation
- 355 **Cajas de transmisión**  
Gearboxes
- 362 **Ángulos de reenvío**  
Corner drives
- 363 **Hoja pasiva**  
Passive sash
- 366 **Falleba de transmisión**  
Transmission rod



## » HERRAJE STAC16

---

El herraje STAC16 está basado en la filosofía de los herrajes de PVC, pero manteniendo ciertas características de los herrajes de Canal Europeo:

Del herraje de PVC ha tomado:

- **Montaje frontal**

Reduce los tiempos de montaje y ofrece la posibilidad de montar el herraje de forma manual, en bancos de montaje, o de forma completamente automatizada.

Del herraje para Canal Europeo mantiene:

- **Modularidad**

Los componentes son siempre los mismos independientemente del tamaño de la hoja y tipo de apertura, lo que se traduce en una importante reducción de las referencias en el almacén. Éstos se conectan entre sí mediante una innovadora pletina de poliamida.

- **Materiales**

Todos los componentes metálicos están fabricados en zamak y acero inoxidable, que tienen un reducido el par galvánico con el aluminio del perfil, y que tienen una resistencia a la corrosión de más de 240 horas en cámara de niebla salina (UNE-EN 1670).

- **Elementos de marco automontables**

Se fijan mediante tornillos espárrago.

## » PERFILES DE CANAL 16

---

En la imagen podemos ver la definición a nivel de cotas, en ella se puede observar lo siguiente:

- **Canal de marco**

Marco estándar Canal Europeo 18 / 14.

- **Canal de hoja**

El herraje STAC16 está diseñado para adaptarse a los dos tipos de canal de 16 mm usados por los sistemas de PVC: con pestañas y sin pestañas, usando fallebas de transmisión específicas.

- **Enfrentamiento marco / hoja, cámara y ala**

El herraje STAC16 es apto para perfiles con eje de 13 mm, cámara de 12 mm y hoja con ala de hasta 20 mm.

El peso máximo que soporta es de **120 kg**. Consulte el catálogo técnico de STAC16 para obtener toda la información de montaje y configuraciones disponibles.

## » STAC16 HARDWARE

---

The STAC16 hardware is based on the philosophy of the PVC hardware but maintains certain characteristics from the Euro Groove hardware:

From the PVC hardware:

- **Frontal assembly**

Reduces the assembly times and offers the possibility of assembling the hardware manually, on assembly beds, or can be assembled completely automatically.

Of the hardware for European Groove maintains:

- **Modularity**

The components are always the same, independently from the sash size and type of opening which translates in to an important reduction of stock references to be held in a warehouse. They are connected with each other by way of an innovative polyamide rod.

- **Materials**

All the metallic components are manufactured in zamak and stainless steel which have a low galvanic couple with the aluminium of the profile and they have a corrosion resistance of more than 240 hours tested in a saline mist chamber (UNE-EN 1670).

- **Frame self-assembly parts**

They are fixed using stud screws.

## » GROOVE 16 PROFILES

---

In the picture we can see the definition in numbers and in it we can see the following:

- **Frame groove**

Euro Groove standard frame 18 / 14.

- **Sash groove**

The STAC16 hardware is designed to adapt to the two types of 16 mm groove used in PVC systems: with flanges and without, so that they have specific rods.

- **Frame / sash face to face, chamber and profile flange**

The STAC16 hardware is suitable for profiles with a 13 mm shaft, a 12 mm chamber and a sash flange up to 20 mm.

The maximum supported weight is **120 kg**. Please consult the STAC16 technical catalogue to obtain all the assembly information and available configurations.



## » ADVANTAGES & CHARACTERISTICS OF STAC16 HARDWARE

- **Front fixing.** Front fixing using: DIN 7504P 3,9 / 3,5 x 25
- **12 mm chamber.** Greater adjustment possibilities, cutting error absorption, locking point interference.
- **8 mm overlap.** Improved weather tightness.
- **Automation.** Possibility of automating for hardware fitting. Quicker assembly.
- **Mixed Aluminium / PVC carpentry.** One unique sash hardware, stock reduction.
- **Ambidextrous hardware.** The components don't have hand-opening or are pre-assembled to the right and can easily be changed to the left.
- **Clipping system.** All the sash components are incorporated with a groove clipping system that allows us to quickly fit all the hardware so that all the component parts can be screwed in one easy step. This important reduction in assembly time translates in to a drastic reduction in costs.
- **Smoothness of operation.** The locking points that are incorporated in the part components have giratory bushings that make sash locking much smoother.
- **Adjustments.** Three dimensional adjustments.
- **Positioning.** All the components are positioned in the side-hung opening position and will be unlocked when the cremone is first operated.
- **Wide range of finishes.** White and black powder coated as well as any colour from the RAL chart.
- **A multitude of accessories.** Micro-ventilation, supplementary friction stays, restriction friction stays, retainer clip,...
- **STAC transmission rod punch and cropper machines.** TFS-02 C16, TFS-05 and TFS-06 machines to cut rods and fit multiple locking points using rivets, the same as in the Euro Groove.

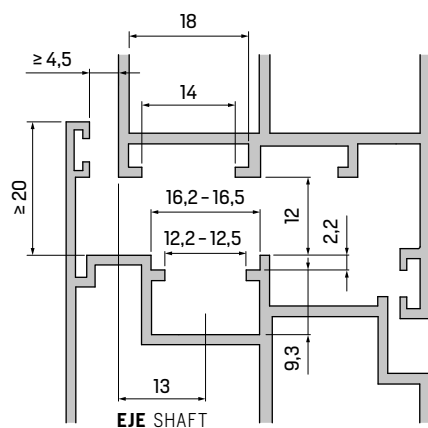

CANAL DE HOJA CON PESTAÑAS SASH GROOVE WITH FLANGES

## » VENTAJAS Y CARACTERÍSTICAS DEL HERRAJE STAC16

- **Fijación frontal.** Fijación mediante tornillos roscachapa: DIN 7504P 3,9 / 3,5 x 25 mm
- **Cámara de 12 mm.** Mayor posibilidad de regulación, absorción de errores de corte, interferencia en puntos de cierre.
- **Remonte 8 mm.** Mayor estanqueidad.
- **Automatización.** Posibilidad de automatización para la colocación herraje. Rapidez de montaje.
- **Carpinterías mixtas Aluminio / PVC.** Un único herraje de hoja, reducción de stocks.
- **Herraje ambidiestro.** Los componentes no tienen mano de apertura o van premontados a derechas pudiendo cambiarse a izquierdas fácilmente.
- **Sistema de clipaje.** Todos los componentes de la hoja incorporan un sistema de clipaje al canal que nos permite colocar rápidamente todo el herraje para posteriormente atornillar todos los componentes en un solo paso. Esta importante reducción en los tiempos de montaje se traduce en una drástica reducción de los costes.
- **Suavidad de funcionamiento.** Los puntos de cierre incorporados en los componentes llevan unos casquillos giratorios que hacen más suave la maniobra de cierre de la hoja.
- **Regulaciones.** Regulaciones en las tres dimensiones.
- **Posicionamiento.** Todos los componentes están posicionados en apertura practicable y se desbloquearán al accionar por primera vez la cremona.
- **Amplia gama de acabados.** Lacados blanco y negro así como cualquier color de la carta RAL.
- **Multitud de accesorios.** Microventilación, compás suplementario y compás limitador, clip retenedor, ...
- **Máquinas troqueladoras de fallebas STAC.** TFS-02 C16, TFS-05 y TFS-06 para cortar las pletinas y colocar múltiples puntos de cierre mediante remaches, al igual que en Canal Europeo.

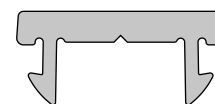

FALLEBA ROD C16

# BISAGRAS ACRUX C16

ACRUX C16 HINGES

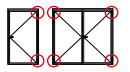

## ACRUX C16 2 PALAS

ACRUX C16 2-LEAF

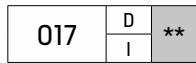

Bisagras de 2 y 3 palas para puerta con perfil de Canal 16.

- Bisagras válidas para eje de 13 mm.
- Regulación lateral de hasta  $\pm 1,2$  mm.
- Las arandelas antifricción han sido fabricadas en acetal (POM) para garantizar un comportamiento óptimo en términos de desgaste.

### ACRUX 2 palas

- Carga máxima con 2 bisagras: **100 kg.**
- Carga máxima con 3 bisagras: **120 kg.**

### ACRUX 3 palas

- Diseñada para aplicaciones más exigentes: puertas de gran tamaño, peso elevado y utilización intensiva.
- Carga máxima con 2 bisagras: **120 kg.**
- Carga máxima con 3 bisagras: **150 kg.**
- A partir de 120 kg es obligatoria la instalación de la pieza de refuerzo en la pala marco (ref. 0517182).

2-leaf and 3-leaf hinges for doors with Groove 16 profile.

- Hinges valid for 13 mm shaft.
- Lateral adjustment up to  $\pm 1.2$  mm.
- The anti-friction washers have been manufactured in acetal (POM) to guarantee optimum behaviour in terms of wear.

### ACRUX 2-leaf

- Maximum load with 2 hinges: **100 kg.**
- Maximum load with 3 hinges: **120 kg.**

### ACRUX 3-leaf

- Designed for more demanding applications large doors, high weight and intensive use.
- Maximum load with 2 hinges: **120 kg.**
- Maximum load with 3 hinges: **150 kg.**
- From 120 kg it is compulsory to install the reinforcement piece on the frame leaf (ref. 0517182).

## ACRUX C16 3 PALAS

ACRUX C16 3-LEAF

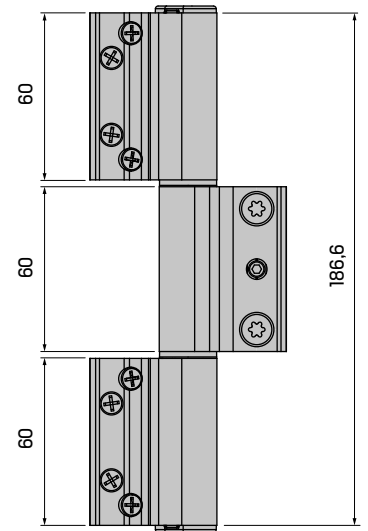
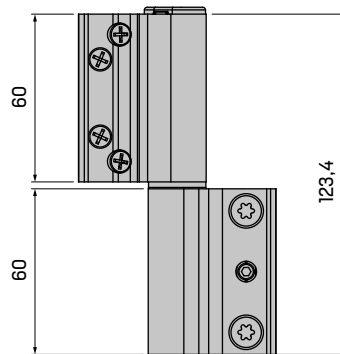
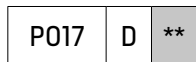

## PIEZA DE REFUERZO

REINFORCEMENT PIECE

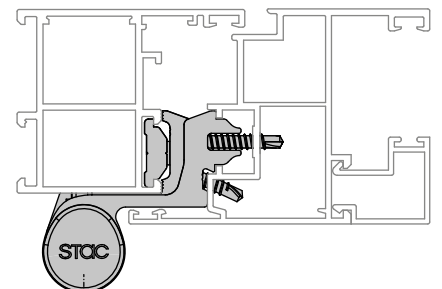
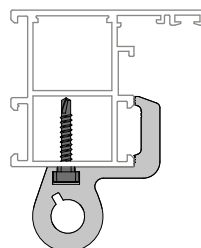
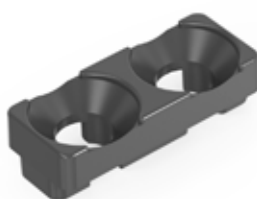
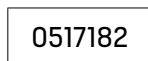

-1,2 mm +1,2 mm

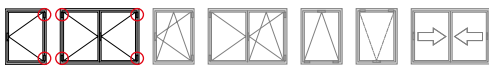

Hinges for windows and doors with Groove 16 profiles.

- Reversible hinge with 2 bodies.
- The hinge has an eccentric pin that allows a 0.8 mm tightening and horizontal adjustment.
- Maximum load with 2 hinges: 80 kg.

Bisagras para ventanas y puertas con perfiles de Canal 16.

- Bisagra reversible de 2 cuerpos.
- La bisagra dispone de un bulón excéntrico que permite regulación de apriete y horizontal de 0.8 mm.
- Carga máxima con 2 bisagras: 80 kg.

**C16 PARA APERTURAS PRACTICABLES**

C16 FOR SIDE-HUNG OPENINGS

\*\*

RAL

C16

AL INX

PA

1760	D	**
	I	



■ **REGULACIONES** ADJUSTMENTS Allen 3 mm

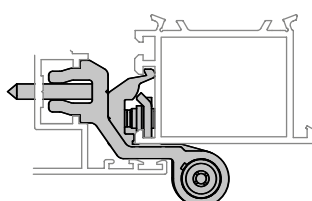
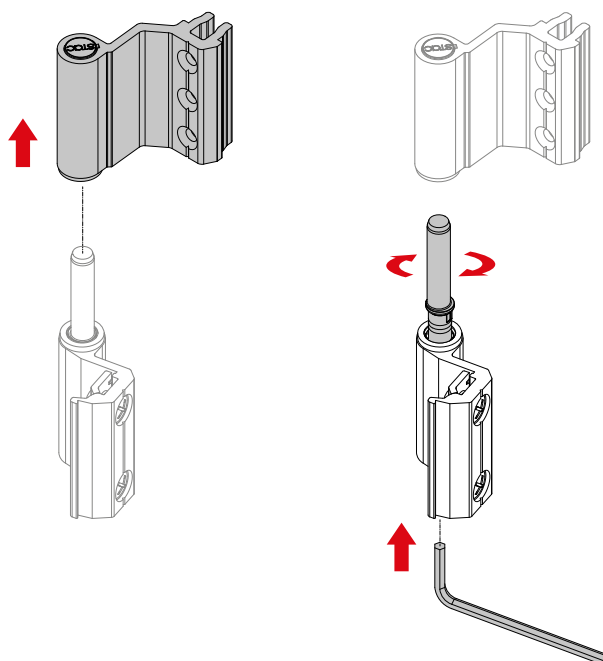
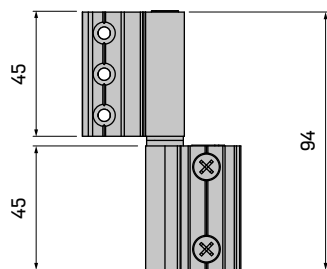
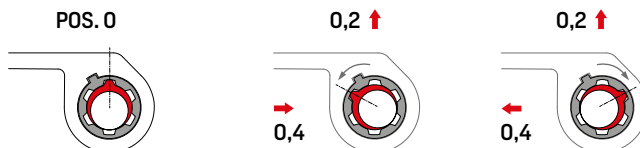

## KITS PARA APERTURA PRACTICABLE DE 1 HOJA

KITS FOR SIDE-HUNG OPENING SINGLE SASH

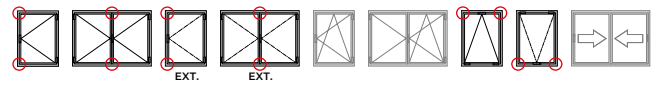

### CIERRE AL INVERSOR CON DOBLE PUNTERO

LOCKING TO INVERTER WITH DOUBLE POINTER

17K1HCI

50



ZM INX



### CIERRE AL MARCO CON DOBLE ÁNGULO DE REENVÍO

LOCKING TO FRAME WITH DOUBLE CORNER DRIVE

17K1HCM

1



ZM INX



Kits de apertura practicable de una hoja para ventanas con perfil de Canal 16.

- Disponibles kit de apertura practicable para cierre al inversor con doble puntero y cierre al marco con doble ángulo de reenvío.

Single sash side-hung opening kits for windows with Groove 16 profile.

- Available side-hung opening kits for locking to inverter with double pointer and locking to frame with double corner drive.

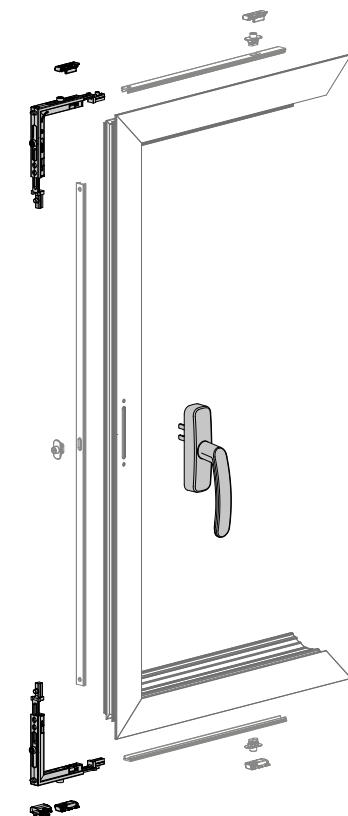
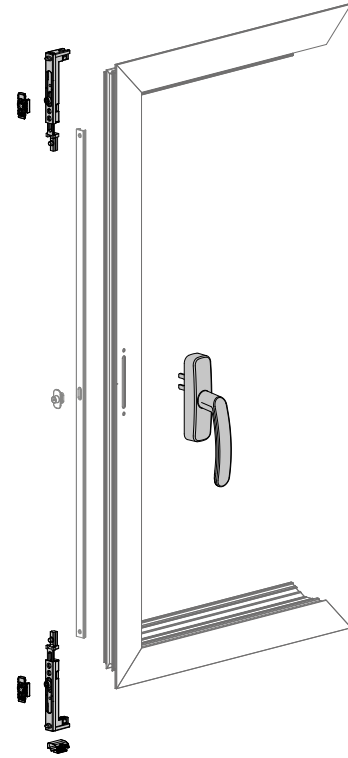

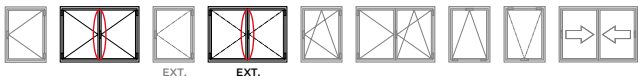

## KITS PARA APERTURA PRACTICABLE DE 2 HOJAS

KITS FOR SIDE-HUNG OPENING DOUBLE SASH

Double sash side-hung opening kits for windows with Groove 16 profile.

- Available side-hung opening kits for locking to inverter with double pointer and locking to frame with double corner drive.

Kits de apertura practicable de dos hojas para ventanas con perfil de Canal 16.

- Disponibles kits de apertura practicable para cierre al inversor con doble puntero y cierre al marco con doble ángulo de reenvío.

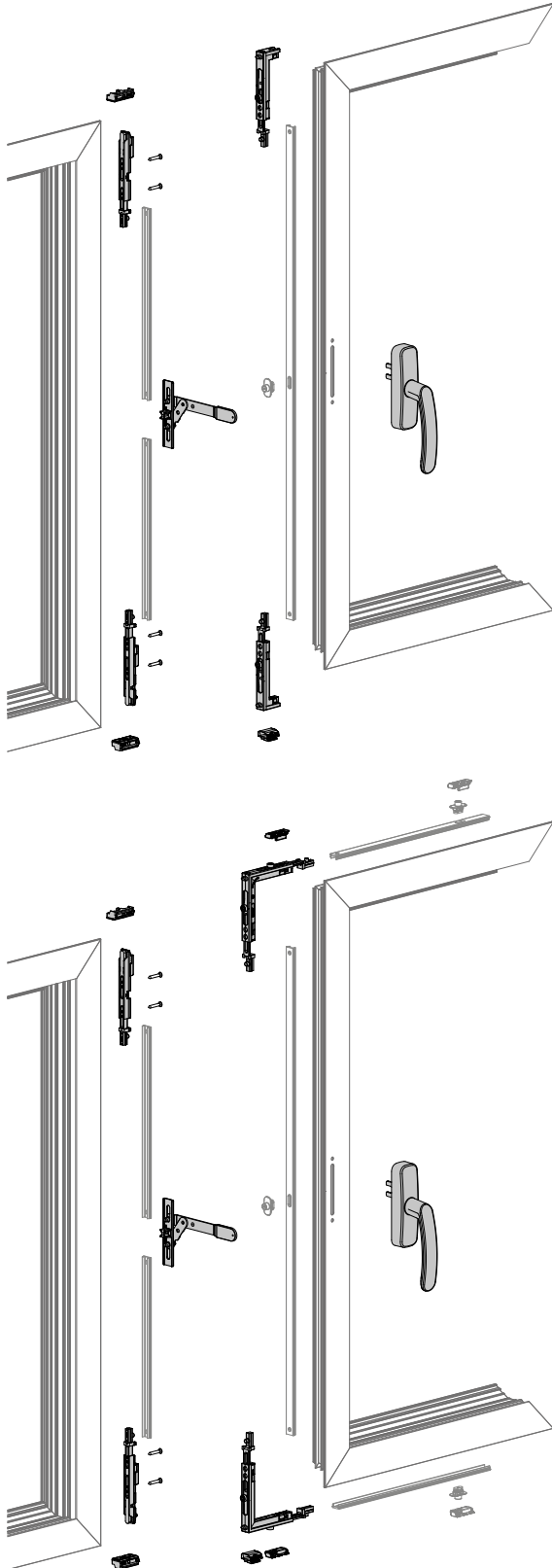

### CIERRE AL INVERSOR CON DOBLE PUNTERO

LOCKING TO INVERTER WITH DOUBLE POINTER



ZM INX

17K2HCI

50



### CIERRE AL MARCO CON DOBLE ÁNGULO DE REENVÍO

LOCKING TO FRAME WITH DOUBLE CORNER DRIVE



ZM INX

17K2HCM

50



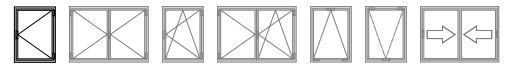

**CIERRE AL INVERSOR CON REMACHES O COLISOS**

LOCKING TO INVERTER WITH RIVETS OR SLOTTED LOCKING POINTS

■ H > 1200 mm

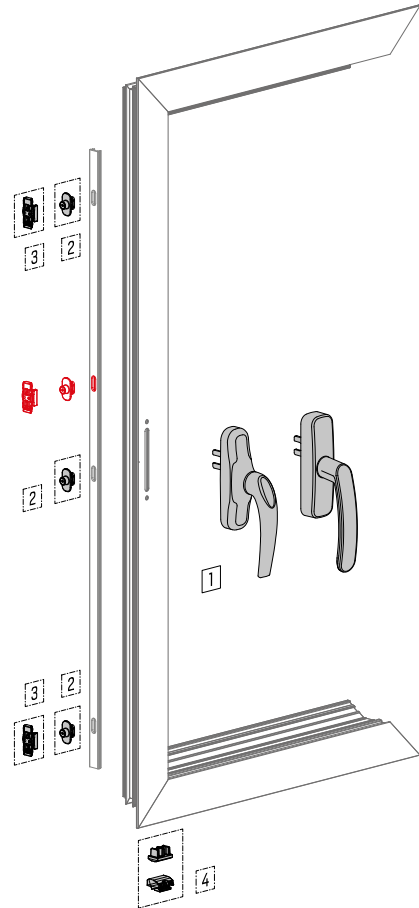
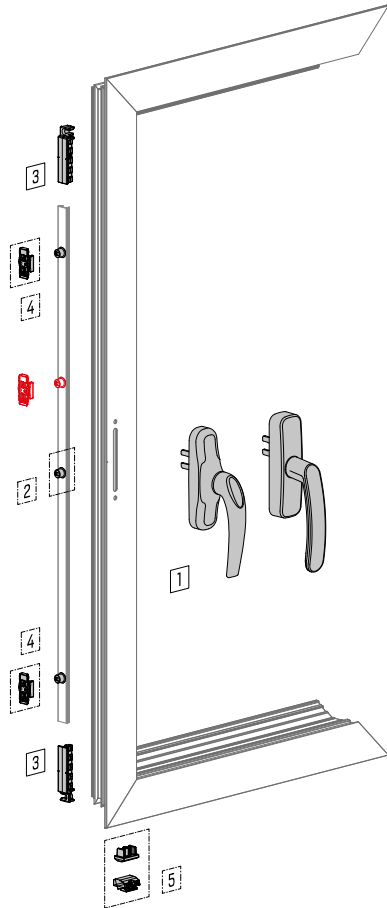

**CON REMACHES**

WITH RIVET LOCKING POINTS



1	<b>CREMONA</b> Ver la sección de « Manillas y cremonas » CREMONE See the chapter on « Handles and cremones »	
2	<b>0517002</b> PUNTO DE CIERRE: REMACHE RIVET LOCKING POINT	50
3	<b>0517083</b> EMBELLECEDOR TERMINAL DE FALLEBA ROD TERMINAL TRIM	50
4	<b>170200</b> PUNTO DE CIERRE REGULABLE ADJUSTABLE LOCKING POINT	100
5	<b>0517226</b> KIT RESBALÓN STAC16 STAC16 ANTI-SLIP KIT	50

**CON COLISOS**

WITH SLOTTED LOCKING POINTS



1	<b>CREMONA</b> Ver la sección de « Manillas y cremonas » CREMONE See the chapter on « Handles and cremones »	
2	<b>178000</b> PUNTO DE CIERRE: COLISO SLOTTED LOCKING POINT	50
3	<b>170200</b> PUNTO DE CIERRE REGULABLE ADJUSTABLE LOCKING POINT	100
4	<b>0517226</b> KIT RESBALÓN STAC16 STAC16 ANTI-SLIP KIT	50



**CIERRE AL INVERSOR CON DOBLE PUNTERO Y COLISOS**  
LOCKING TO INVERTER WITH DOUBLE POINTER AND SLOTTED LOCKING POINTS



H > 1200 mm

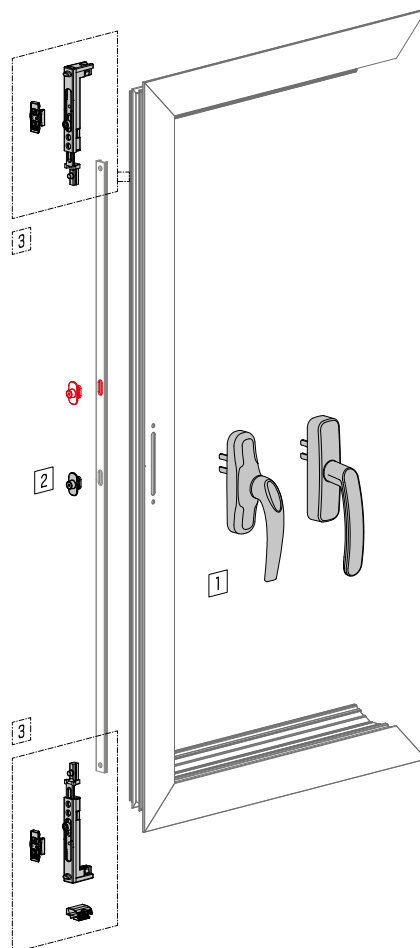
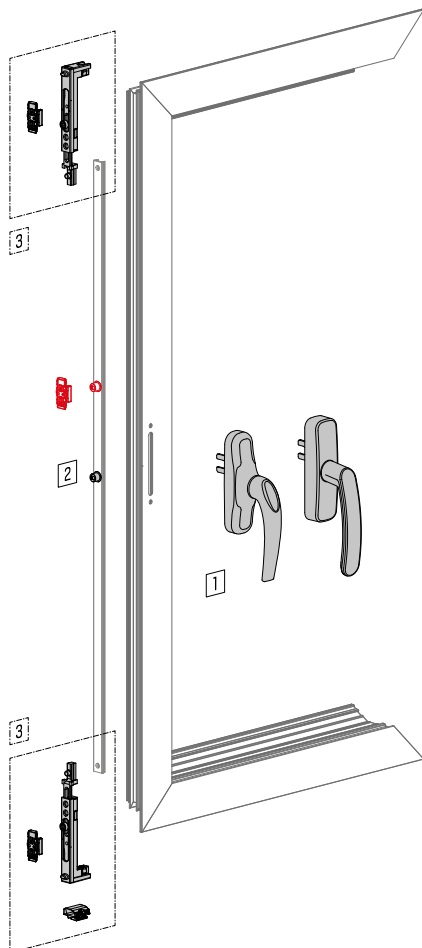

**CON DOBLE PUNTERO Y REMACHES**

WITH DOUBLE POINTER AND RIVET LOCKING POINTS



1 **CREMONA** Ver la sección de « Manillas y cremonas »  
CREMONE See the chapter on « Handles and cremones »

**PUNTERO STAC16**  
STAC16 POINTER

2 **17K1HCI** **PUNTO DE CIERRE REGULABLE**  
ADJUSTABLE LOCKING POINT 50

**RESBALÓN DE MARCO**  
FRAME ANTI-SLIP

3 **0517002** **PUNTO DE CIERRE: REMACHE**  
RIVET LOCKING POINT 50

**CON DOBLE PUNTERO Y COLISOS**

WITH DOUBLE POINTER AND SLOTTED LOCKING POINTS



1 **CREMONA** Ver la sección de « Manillas y cremonas »  
CREMONE See the chapter on « Handles and cremones »

**PUNTERO STAC16**  
STAC16 POINTER

2 **17K1HCI** **PUNTO DE CIERRE REGULABLE**  
ADJUSTABLE LOCKING POINT 50

**RESBALÓN DE MARCO**  
FRAME ANTI-SLIP

3 **178000** **PUNTO DE CIERRE: COLISO**  
SLOTTED LOCKING POINT 100

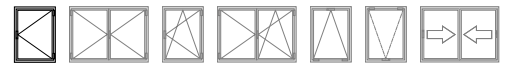

**CIERRE AL MARCO CON DOBLE ÁNGULO DE REENVÍO Y REMACHES O COLISOS**

LOCKING TO FRAME WITH DOUBLE CORNER DRIVE AND RIVET OR SLOTTED LOCKING POINTS

■ H > 1200 mm

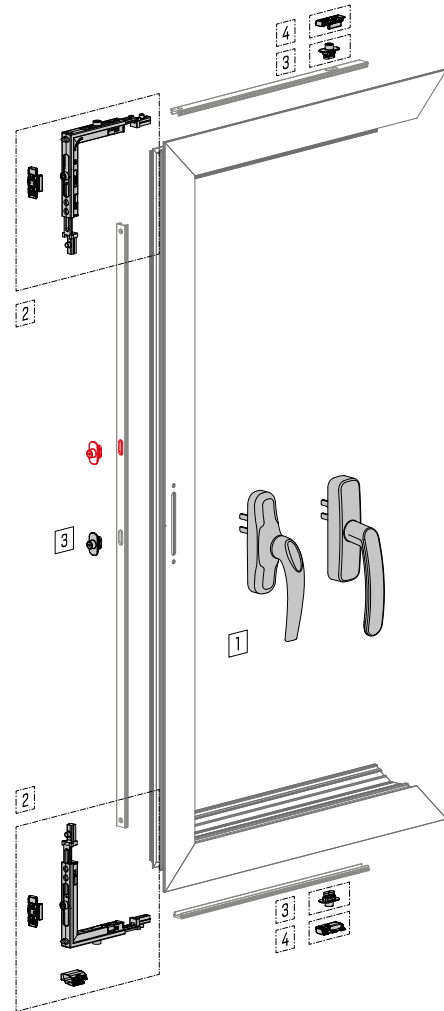
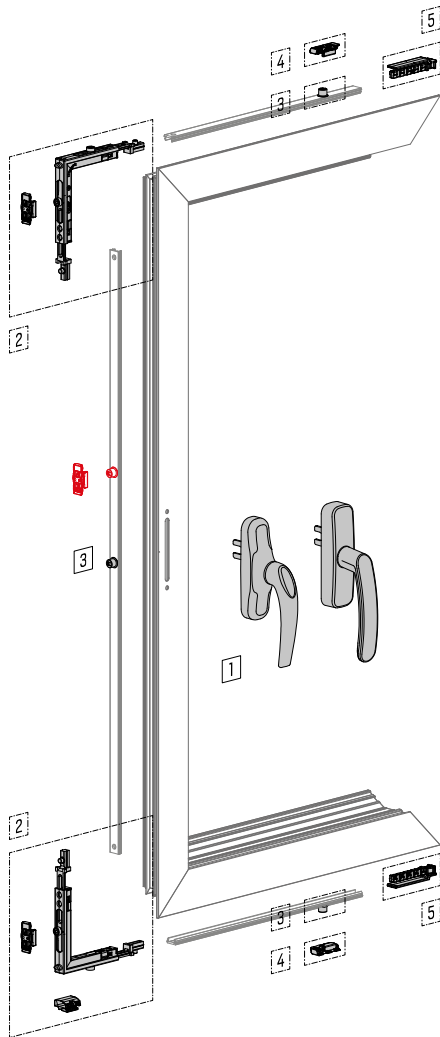

**CON DOBLE ÁNGULO DE REENVÍO Y REMACHES**

WITH DOUBLE CORNER DRIVE AND RIVET LOCKING POINTS



1 **CREMONA** Ver la sección de « Manillas y cremonas »  
CREMONE See the chapter on « Handles and cremones »

**ÁNGULO DE REENVÍO STAC16**  
STAC16 CORNER DRIVE

2 **17K1HCM** **PUNTO DE CIERRE REGULABLE**  
ADJUSTABLE LOCKING POINT 1

**RESBALÓN DE MARCO**  
FRAME ANTI-SLIP

3 **0517002** **PUNTO DE CIERRE: REMACHE**  
RIVET LOCKING POINT 50

4 **170200** **PUNTO DE CIERRE REGULABLE**  
ADJUSTABLE LOCKING POINT 100

5 **0517083** **EMBELLECEDOR TERMINAL DE FALLEBA**  
ROD TERMINAL TRIM 50

**CON DOBLE ÁNGULO DE REENVÍO Y COLISOS**

WITH DOUBLE CORNER DRIVE AND SLOTTED LOCKING POINTS



1 **CREMONA** Ver la sección de « Manillas y cremonas »  
CREMONE See the chapter on « Handles and cremones »

**ÁNGULO DE REENVÍO STAC16**  
STAC16 CORNER DRIVE

2 **17K1HCM** **PUNTO DE CIERRE REGULABLE**  
ADJUSTABLE LOCKING POINT 1

**RESBALÓN DE MARCO**  
FRAME ANTI-SLIP

3 **178000** **PUNTO DE CIERRE: COLISO**  
SLOTTED LOCKING POINT 100

4 **170200** **PUNTO DE CIERRE REGULABLE**  
ADJUSTABLE LOCKING POINT 100





**CIERRE AL MARCO CON ÁNGULO DE REENVÍO Y REMACHES O COLISOS**  
LOCKING TO FRAME WITH DOUBLE CORNER DRIVE AND RIVET OR SLOTTED LOCKING POINTS



H > 1200 mm

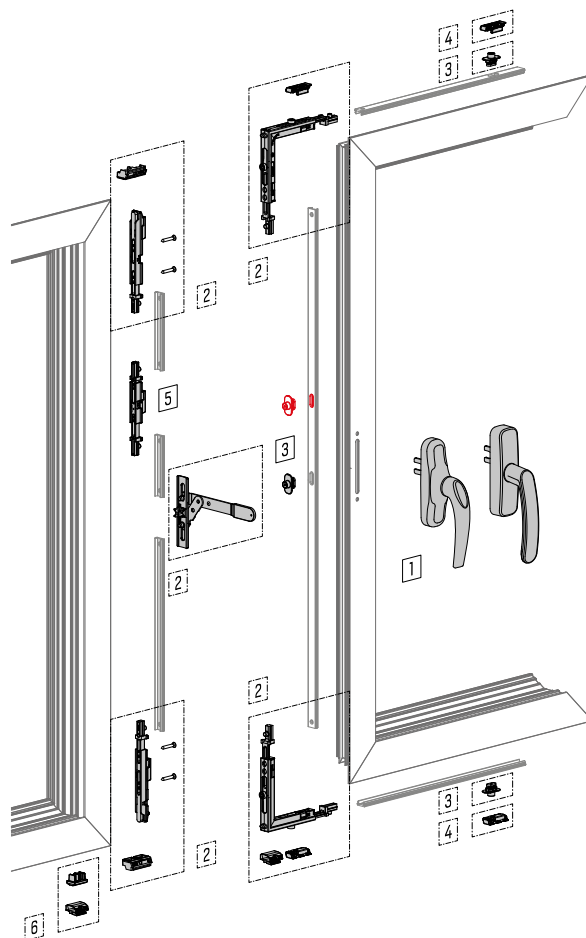
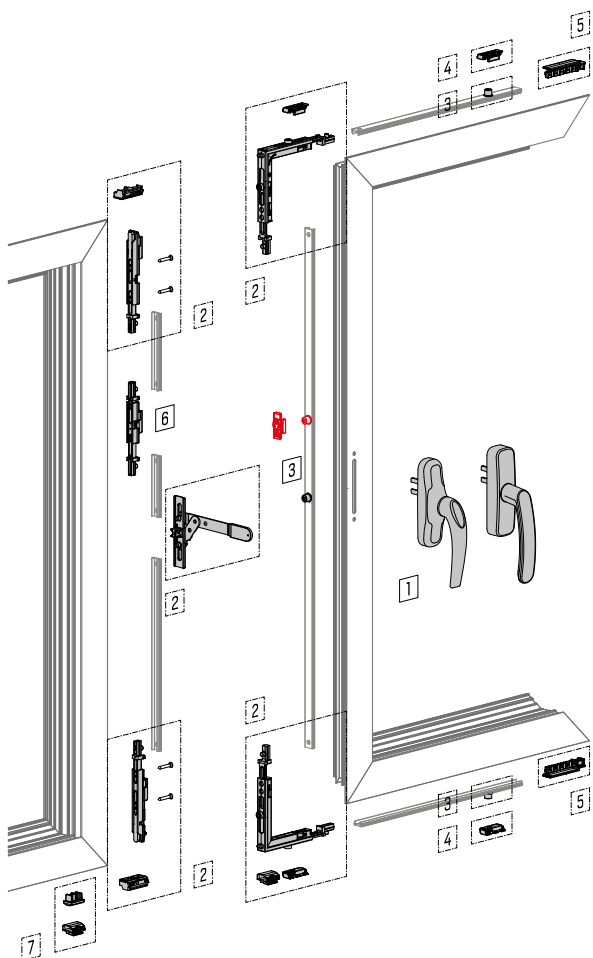

**CON DOBLE ÁNGULO DE REENVÍO Y REMACHES**  
WITH DOUBLE CORNER DRIVE AND RIVET LOCKING POINTS



1 **CREMONA** Ver la sección de « Manillas y cremonas »  
CREMONE See the chapter on « Handles and cremones »

**ÁNGULO DE REENVÍO STAC16**  
STAC16 CORNER DRIVE

2 **17K2HCM** **PUNTO DE CIERRE REGULABLE**  
ADJUSTABLE LOCKING POINT 50

**RESBALÓN DE MARCO**  
FRAME ANTI-SLIP

**KIT PASADOR DE PALANCA BIDIRECCIONAL STAC16**  
STAC16 TWO-WAY SHOOTBOLT LEVER KIT

3 **0517002** **PUNTO DE CIERRE: REMACHE**  
RIVET LOCKING POINT 50

4 **170200** **PUNTO DE CIERRE REGULABLE**  
ADJUSTABLE LOCKING POINT 100

5 **0517083** **EMBELLECEDOR TERMINAL DE FALLEBA**  
ROD TERMINAL TRIM 50

6 **177000** **CERRADERO PARA EL INVERSOR**  
INVERTER KEEPER 50

7 **0517226** **KIT RESBALÓN STAC16**  
STAC16 ANTI-SLIP KIT 50

**CON DOBLE ÁNGULO DE REENVÍO Y COLISOS**  
WITH DOUBLE CORNER DRIVE AND SLOTTED LOCKING POINTS



1 **CREMONA** Ver la sección de « Manillas y cremonas »  
CREMONE See the chapter on « Handles and cremones »

**ÁNGULO DE REENVÍO STAC16**  
STAC16 CORNER DRIVE

2 **17K2HCM** **PUNTO DE CIERRE REGULABLE**  
ADJUSTABLE LOCKING POINT 50

**RESBALÓN DE MARCO**  
FRAME ANTI-SLIP

**KIT PASADOR DE PALANCA BIDIRECCIONAL STAC16**  
STAC16 TWO-WAY SHOOTBOLT LEVER KIT

3 **178000** **PUNTO DE CIERRE: COLISO**  
SLOTTED LOCKING POINT 100

4 **170200** **PUNTO DE CIERRE REGULABLE**  
ADJUSTABLE LOCKING POINT 100

5 **177000** **CERRADERO PARA EL INVERSOR**  
INVERTER KEEPER 50

6 **0517226** **KIT RESBALÓN STAC16**  
STAC16 ANTI-SLIP KIT 50

## CONFIGURACIÓN PARA APERTURA PRACTICABLE

### SIDE-HUNG OPENING CONFIGURATION



#### CIERRE AL INVERSOR CON DOBLE PUNTERO Y REMACHES O COLISOS

LOCKING TO INVERTER WITH DOUBLE POINTER AND RIVET OR SLOTTED LOCKING POINTS

■ H > 1200 mm

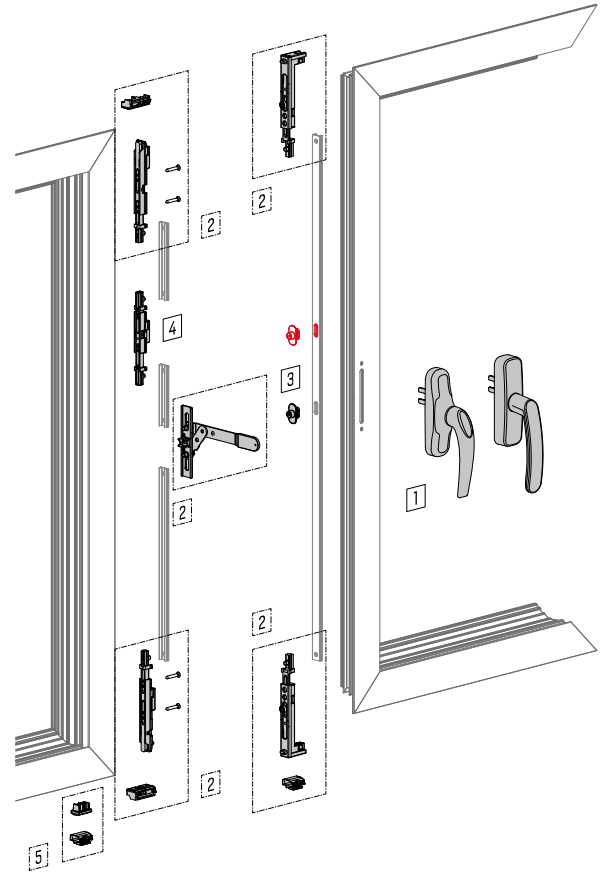
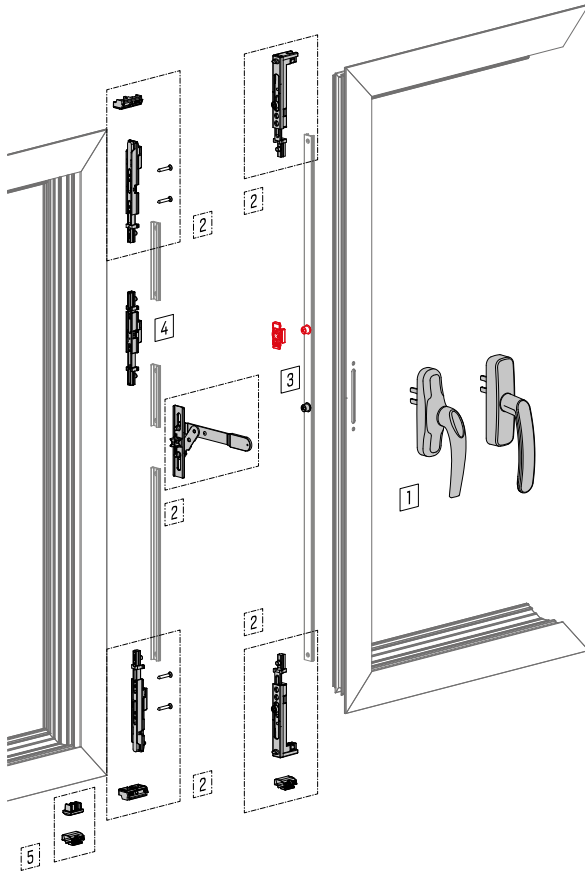

#### CON DOBLE PUNTERO Y REMACHES

WITH DOUBLE POINTER AND RIVET LOCKING POINTS



1 **CREMONA** Ver la sección de « Manillas y cremonas »  
CREMONE See the chapter on « Handles and cremones »

##### PUNTERO STAC16

STAC16 POINTER

##### PUNTO DE CIERRE REGULABLE

ADJUSTABLE LOCKING POINT

2 **17K2HCI**

1

##### RESBALÓN DE MARCO

FRAME ANTI-SLIP

##### KIT PASADOR DE PALANCA BIDIRECCIONAL STAC16

STAC16 TWO-WAY SHOOTBOLT LEVER KIT

3 **0517002**

##### PUNTO DE CIERRE: REMACHE

RIVET LOCKING POINT

50

4 **177000**

##### CERRADERO PARA EL INVERSOR

INVERTER KEEPER

50

5 **0517226**

##### KIT RESBALÓN STAC16

STAC16 ANTI-SLIP KIT

50

#### CON DOBLE PUNTERO Y COLISOS

WITH DOUBLE POINTER AND SLOTTED LOCKING POINTS



1 **CREMONA** Ver la sección de « Manillas y cremonas »  
CREMONE See the chapter on « Handles and cremones »

##### ÁNGULO DE REENVÍO STAC16

STAC16 CORNER DRIVE

##### PUNTO DE CIERRE REGULABLE

ADJUSTABLE LOCKING POINT

2 **17K2HCI**

1

##### RESBALÓN DE MARCO

FRAME ANTI-SLIP

##### KIT PASADOR DE PALANCA BIDIRECCIONAL STAC16

STAC16 TWO-WAY SHOOTBOLT LEVER KIT

3 **178000**

##### PUNTO DE CIERRE: COLISO

SLOTTED LOCKING POINT

100

4 **177000**

##### CERRADERO PARA EL INVERSOR

INVERTER KEEPER

50

5 **0517226**

##### KIT RESBALÓN STAC16

STAC16 ANTI-SLIP KIT

50

**CIERRE AL MARCO CON COLISOS**  
LOCKING TO FRAME WITH SLOTTED LOCKING POINTS



H > 1200 mm

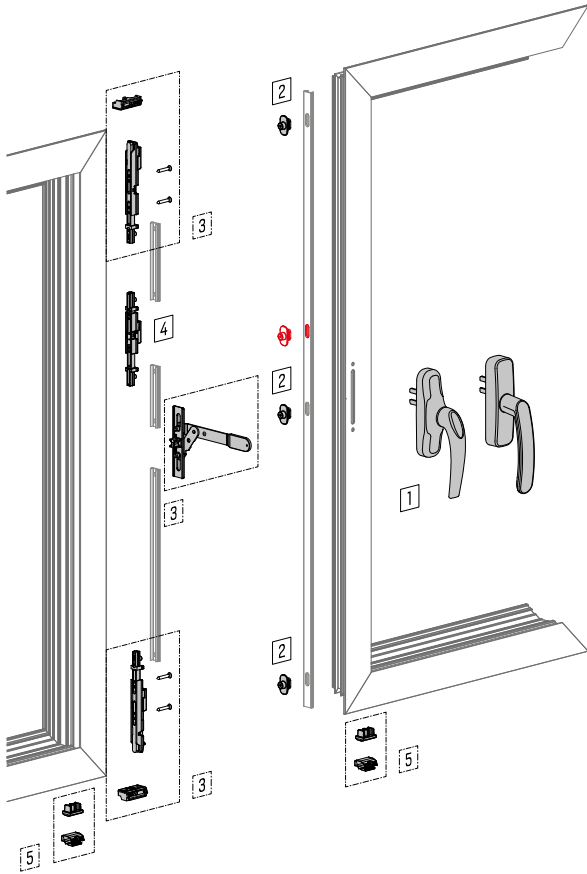

**CON COLISOS**  
WITH SLOTTED LOCKING POINTS



1	<b>CREMONA</b> Ver la sección de « Manillas y cremonas » CREMONE See the chapter on « Handles and cremones »	
2	<b>178000</b> PUNTO DE CIERRE: COLISO SLOTTED LOCKING POINT	100
3	<b>171600</b> KIT PASADOR DE PALANCA BIDIRECCIONAL STAC16 STAC16 TWO-WAY SHOOTBOLT LEVER KIT	20
4	<b>177000</b> CERRADERO PARA EL INVERSOR INVERTER KEEPER	50
5	<b>0517226</b> KIT RESBALÓN STAC16 STAC16 ANTI-SLIP KIT	50

## KIT BASE OSCILOBATIENTE C16

C16 TILT & TURN BASE KIT

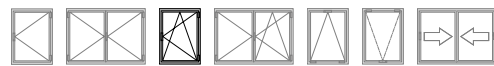

### CIERRE AL INVERSOR SIN CREMONA

LOCKING TO INVERTER WITHOUT CREMONE

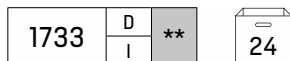

Kit base de bisagras C16 para aperturas oscilobatientes con cierre al inversor.

- Carga máxima por hoja: **120 kg.**
- Los kits son válidos para ventanas con eje de 13 mm y ala de 20 mm.
- Las bisagras C16 admiten regulación en las 3 dimensiones.
- Todos los elementos de la hoja incorporan un clip que permite el pre-posicionado en el montaje.
- Los kits oscilobatientes permiten la posibilidad de acoplar múltiples puntos de cierre adicionales.

**Compases no incluidos. Consulte los compases compatibles en la página 345.**

C16 hinge base kit for tilt & turn window openings with locking to inverter.

- Maximum load per sash: **120 kg.**
- The kits are valid for windows with 13 mm shaft and 20 mm flange.
- The C16 hinges can be adjusted in all 3 dimensions.
- All the elements of the sash incorporate a clip that allows the pre-positioning in the assembly.
- The tilt & turn kits allow the possibility of coupling multiple additional locking points.

**Friction stays not included. See page 345 for compatible friction stays.**

### CIERRE AL INVERSOR CON CREMONA LYRA

LOCKING TO INVERTER WITH LYRA CREMONE

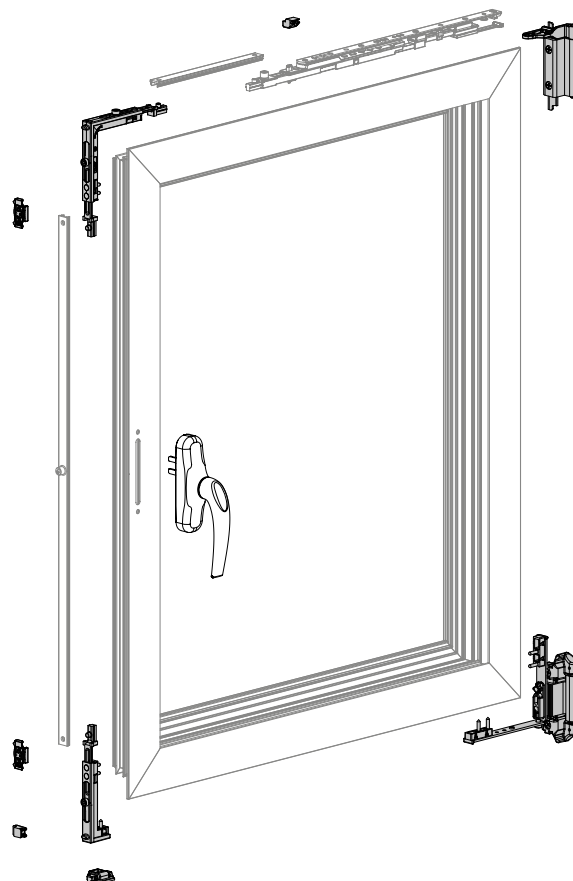
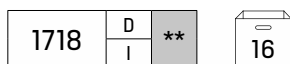

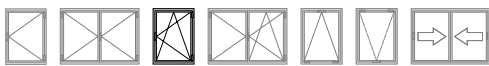

## KIT BASE OSCIOBATIENTE C16

C16 TILT & TURN BASE KIT

C16 hinge base kit for tilt & turn window openings with locking to frame.

- Maximum load per sash: **120 kg**.
- The kits are valid for windows with 13 mm shaft and 20 mm flange.
- The C16 hinges can be adjusted in all 3 dimensions.
- All the elements of the sash incorporate a clip that allows the pre-positioning in the assembly.
- The tilt & turn kits allow the possibility of coupling multiple additional locking points.

Friction stays not included. See page 345 for compatible friction stays.

Kit base de bisagras C16 para aperturas de ventana oscilobatientes con cierre al marco.

- Carga máxima por hoja: **120 kg**.
- Los kits son válidos para ventanas con eje de 13 mm y ala de 20 mm.
- Las bisagras C16 admiten regulación en las 3 dimensiones.
- Todos los elementos de la hoja incorporan un clip que permite el preposicionado en el montaje.
- Los kits oscilobatientes permiten la posibilidad de acoplar múltiples puntos de cierre adicionales.

Compases no incluidos. Consulte los compases compatibles en la página 345.

## CIERRE AL MARCO SIN CREMONA

LOCKING TO FRAME WITHOUT CREMONE

\*\*



24

171010	D	**
	I	



AL ZM

PA INX



## CIERRE AL MARCO CON CREMONA LYRA

LOCKING TO FRAME WITH LYRA CREMONE

\*\*



16

1732	D	**
	I	



AL ZM

PA INX

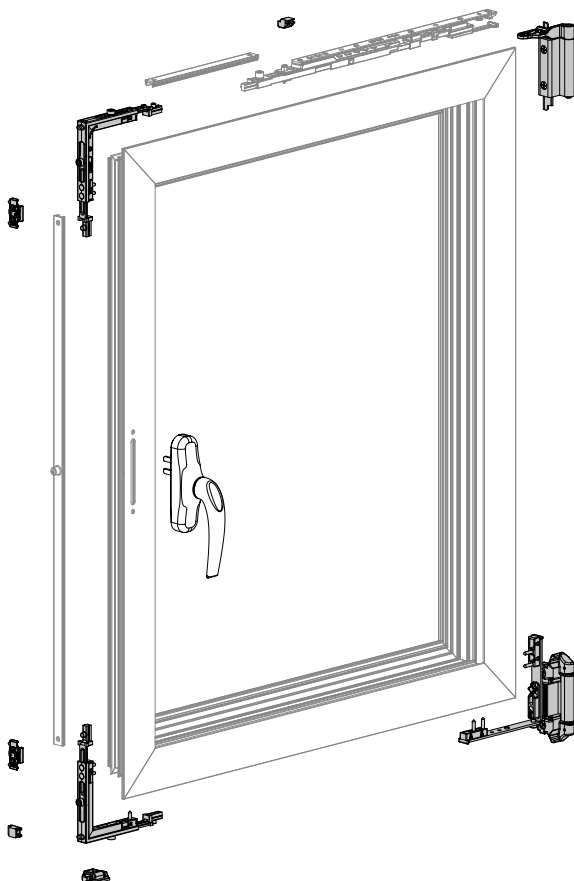
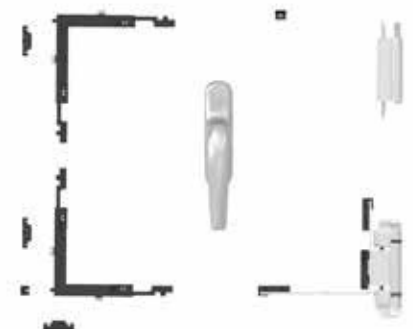

## KIT BASE OSCLOBATIENTE C16 PLUS

C16 PLUS TILT & TURN BASE KIT

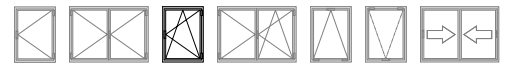

### CIERRE AL MARCO SIN CREMONA

LOCKING TO FRAME WITHOUT CREMONE

P1739	D	**
	I	

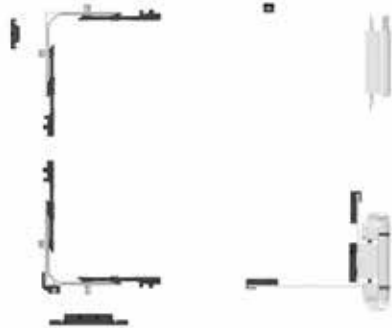

Kit base de bisagras C16 para aperturas de ventana oscilobatientes con cierre al marco y maniobra lógica.

- Carga máxima por hoja: **120 kg.**
- Las bisagras C16 admiten regulación en las 3 dimensiones.
- Todos los elementos de la hoja incorporan un clip que permite el pre-posicionamiento en el montaje.
- Los kits oscilobatientes permiten la posibilidad de acoplar múltiples puntos de cierre adicionales.

#### Maniobra lógica

- La manilla de una ventana con maniobra lógica admite 3 posiciones:

Manilla 0°: ventana cerrada

Manilla 90°: ventana en oscilo

Manilla 180°: ventana en practicable

- Los kits de maniobra lógica son idóneos para el uso de cremonas **LYRA BLOCK** o **SIRIUS BLOCK**, ya que proporcionan dos posiciones de bloqueo que permiten oscilar pero no abrir la ventana.

**Compases no incluidos. Consulte los compases compatibles en la página 345.**

C16 hinge base kit for tilt & turn window openings with locking to frame and tilt-before-turn.

- Maximum load per sash: **120 kg.**
- The C16 hinges can be adjusted in all 3 dimensions.
- All the elements of the sash incorporate a clip that allows the pre-positioning in the assembly.
- The tilt & turn kits allow the possibility of coupling multiple additional locking points.

#### Tilt-before-turn

- The handle of a tilt-before-turn window can be set to 3 positions:

Handle 0°: close window position

Handle 90°: tilt window position

Handle 180°: turn window position

- The tilt-before-turn kits are suitable for the use of **LYRA BLOCK** or **SIRIUS BLOCK** cremones, as they provide two locking positions that allow the window to be tilt but not opened.

**Friction stays not included. See page 345 for compatible friction stays.**

### CIERRE AL MARCO CON CREMONA LYRA

LOCKING TO FRAME WITH LYRA CREMONE

P1732	D	**
	I	



### MANIOBRA LÓGICA SIN CREMONA

TILT-BEFORE-TURN WITHOUT CREMONE

P1723	D	**
	I	

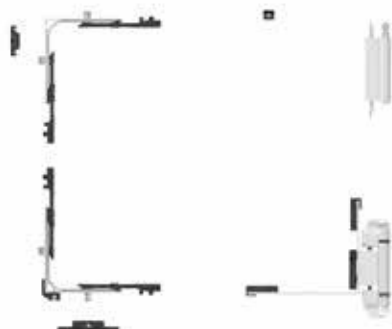

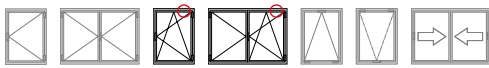

## COMPASES OSCIOBATIENTES TILT & TURN FRICTION STAYS

The friction stays allow tilt & turn openings to be made in combination with the different mechanisms.

- The tilt & turn friction stays have a mechanism that allows the adjustment of the opening of the sash in the tilt position.
- The tilt & turn friction stays have a stop that allows the positioning of the sash.

Los compases permiten realizar aperturas oscilobatientes en combinación con los diferentes mecanismos.

- Los compases oscilobatientes disponen de un mecanismo que permite la regulación de la apertura de la hoja en posición de oscilo.
- Los compases disponen de un tope que permiten el posicionado de la hoja.

### REFERENCIA REFERENCE

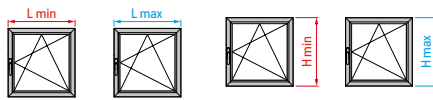

REFERENCIA	D	I	**					
170301	D	I	**	GRANDE LARGE	582	1600	390	2400
170304	D	I	**					
170302	D	I	**	MEDIANO MEDIUM	498	1200	390	2400
170305	D	I	**					
170303	D	I	**	PEQUEÑO SMALL	405	800	390	2400
170307	D	I	**					
170306	D	I	**	MINI	370	445	430	1200

### » APERTURA DE LA HOJA SEGÚN COMPÁS Y POSICIÓN DE REGULACIÓN SASH OPENING ACCORDING TO FRICTION STAY AND ADJUSTMENT POSITION

REF.	D	I	**		POS. 1	POS. 2	POS. 3
170301	D	I	**	GRANDE LARGE	191	155	101
170304	D	I	**				
170302	D	I	**	MEDIANO MEDIUM	168	112	-
170305	D	I	**				
170303	D	I	**	PEQUEÑO SMALL	130	85	-
170307	D	I	**				
170306	D	I	**	MINI	130	85	-

## COMPASES PARA MANIOBRA TRADICIONAL FRICTION STAYS FOR TRADITIONAL MANOEUVRING



GRANDE LARGE	170301	D	I	**
MEDIANO MEDIUM	170302	D	I	**
PEQUEÑO SMALL	170303	D	I	**
MINI MINI	170306	D	I	**



10

## COMPASES PARA MANIOBRA LÓGICA FRICTION STAYS FOR TILT-BEFORE-TURN MANOEUVRING



GRANDE LARGE	170304	D	I	**
MEDIANO MEDIUM	170305	D	I	**
PEQUEÑO SMALL	170307	D	I	**



10

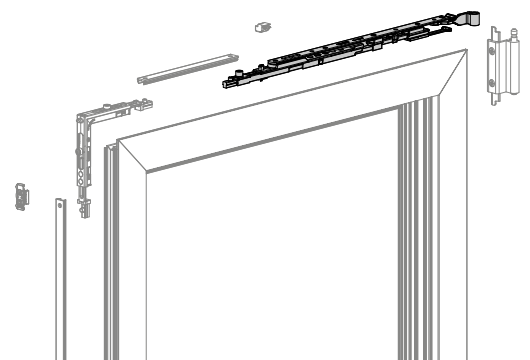

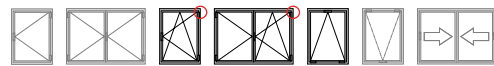

KIT ÁNGULO DE REENVÍO SUPLEMENTARIO  
SUPPLEMENTARY CORNER DRIVE KIT

172100

25

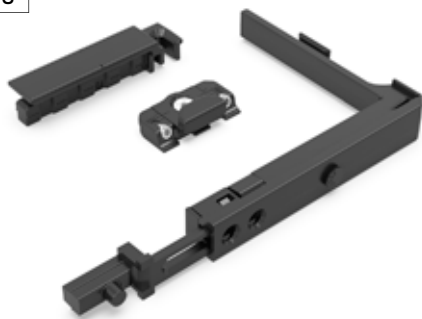

ZM INX

PA

Ángulo de reenvío que permite obtener un punto de cierre vertical adicional.

- El ángulo se acopla al compás para disponer de uno o más puntos de cierre adicionales entre las bisagras.
- Ángulo recomendado para su instalación en ventanas con hojas superiores a 1200 mm de altura.
- El ángulo de reenvío se suministra con un conjunto para punto de cierre.

Corner drive that allows an additional vertical locking point to be obtained.

- The corner drive is coupled to the friction stay to provide one or more additional locking points between the hinges.
- Recommended corner drive for installation on windows with sashes over 1200 mm high.
- The corner drive is supplied with a locking point set.

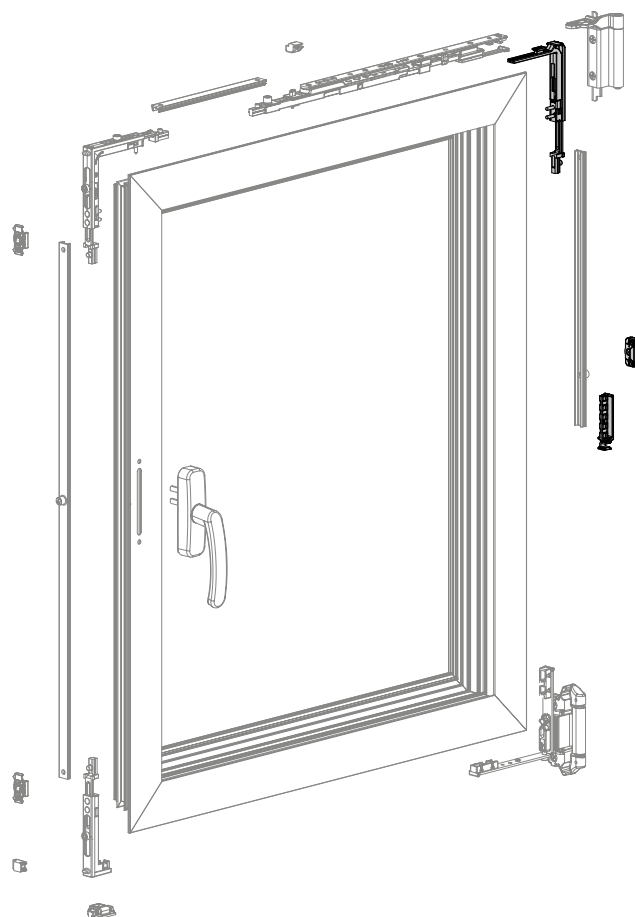



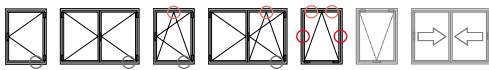

Optional supplementary friction stay designed for installation on wide tilt & turn windows.

- Friction stay recommended for installing on tilt & turn windows with more than 1200 mm sash width.
- It acts as a reinforcement to the main friction stay by reducing the forces and vibrations on the friction stay when the window is in the tilt position.
- The friction stay is supplied pre-assembled allowing for a considerable reduction in assembly time.
- The supplementary friction stay is valid for bottom-hung window opening configurations with perimeter closing.

Compás suplementario opcional diseñado para su instalación en ventanas oscilobatientes de gran anchura.

- Compás recomendado para su instalación en ventanas oscilobatientes con más de 1200 mm de ancho de hoja.
- Actúa como refuerzo al compás principal reduciendo los esfuerzos y vibraciones en el mismo cuando la ventana está en posición de oscilo.
- El compás se suministra premontado permitiendo reducir considerablemente el tiempo de montaje.
- El compás suplementario es válido para configuraciones de ventanas abatibles con cierre perimetral.

**Limiting friction stay**

- Friction stay that allows to limit the opening on bottom-hung, side-hung and tilt & turn windows.
- The guide has an adjustable stop that allows a greater or lesser opening of the sash.

**Compás limitador**

- Compás que permite limitar la apertura en ventanas abatibles, practicables y oscilobatientes.
- La guía dispone de un tope regulable que permite una mayor o menor apertura de la hoja.

**COMPÁS SUPLEMENTARIO**  
 SUPPLEMENTARY FRICTION STAY



130400



**COMPÁS LIMITADOR**  
 LIMITING FRICTION STAY



130500



■ **APERTURAS PRACTICABLES Y OSCILOBIENTES**  
 SIDE-HUNG AND TILT & TURN OPENINGS

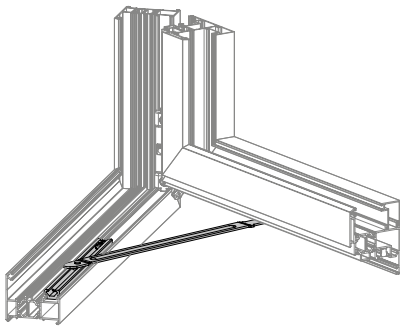

■ **APERTURAS ABATIBLES**  
 BOTTOM-HUNG OPENINGS

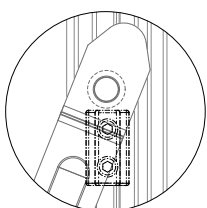

**Detalle del tope regulable**  
 Adjustable stop guide detail

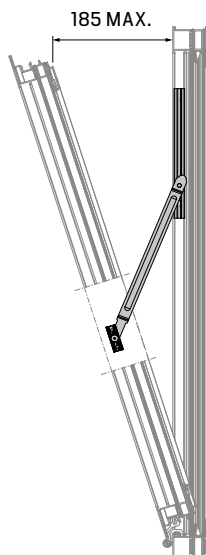

■ **COMPÁS SUPLEMENTARIO PARA MANIOBRA TRADICIONAL**  
 SUPPLEMENTARY FRICTION STAY FOR TRADITIONAL MANOEUVRE

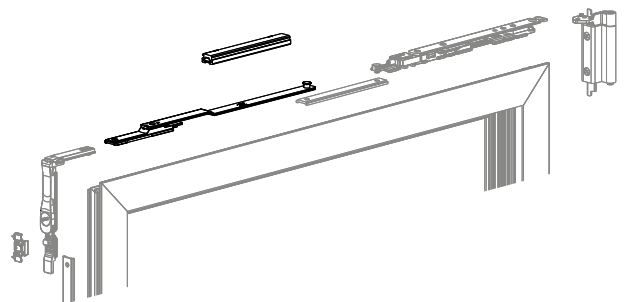

■ **COMPÁS SUPLEMENTARIO PARA MANIOBRA LÓGICA**  
 SUPPLEMENTARY FRICTION STAY FOR TILT-BEFORE-TURN MANOEUVRE

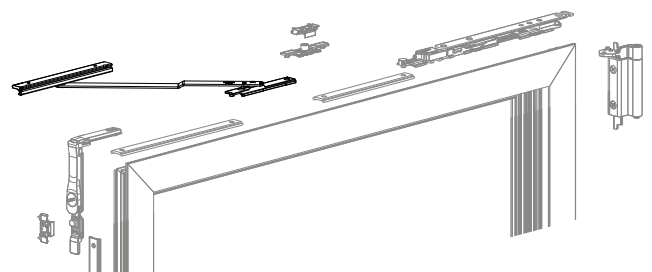

## COMPÁS LIMITADOR PARA VENTILACIÓN

### LIMITING FRICTION STAY FOR VENTILATION

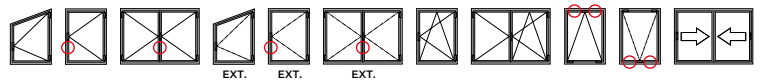

## COMPÁS LIMITADOR PARA VENTILACIÓN

### LIMITING FRICTION STAY FOR VENTILATION

130720



ZM AL

INX

15



Compás limitador que permite hacer posiciones estables de ventilación en aperturas practicables.

- Premontaje directo en hoja y en marco, permitiendo reducir considerablemente el tiempo de montaje.
- La apertura para la ventilación es fácilmente regulable, y el resorte de retención permite una posición estable de la misma.
- El compás limitador ofrece la posibilidad de fijación adicional mediante tornillos rosca-chapa.

Limiting friction stay that allows stable ventilation position in side-hung window openings.

- Direct pre-assembly on the sash and on the frame, allowing for a considerable reduction in assembly time.
- The opening for ventilation is easily adjustable, and the retaining spring allows a stable position of the ventilation.
- The limiting friction stay offers the possibility of additional fixation by means of self-tapping screws.

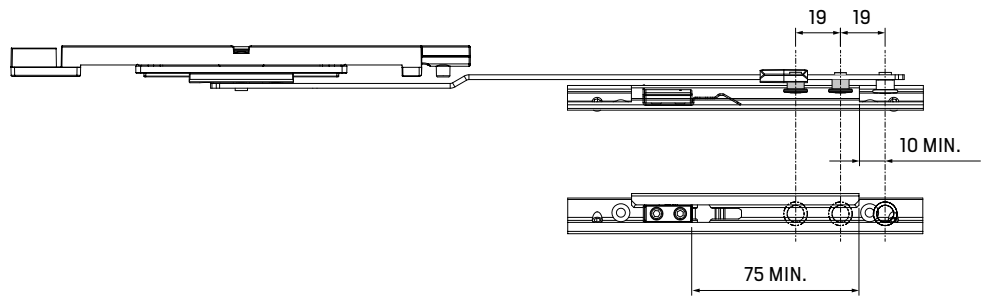
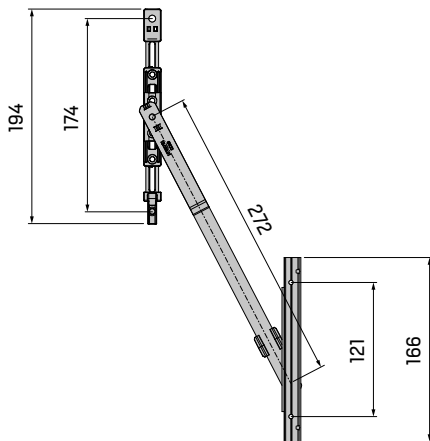

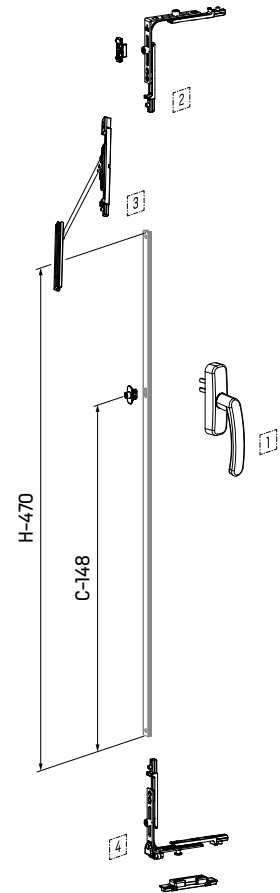
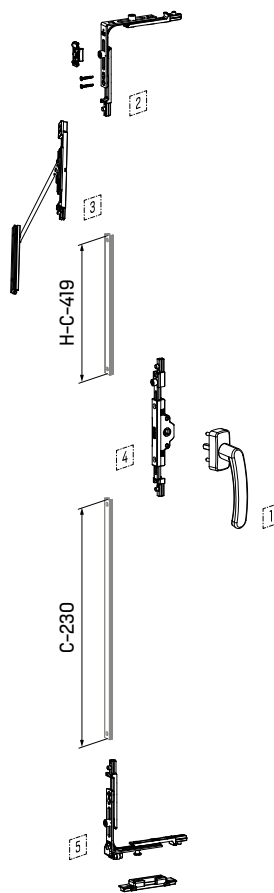
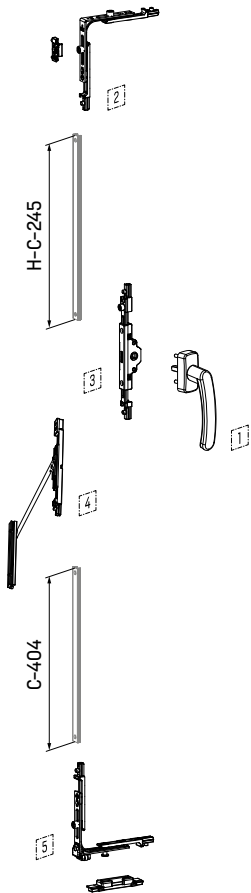
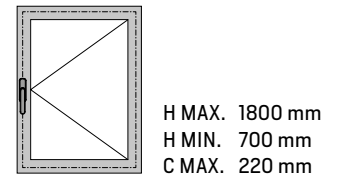
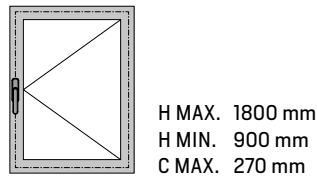
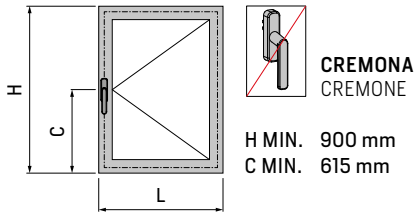

» **CONFIGURACIÓN** CONFIGURATION 1

1	A0771	**	<b>MANILLA SIRIUS</b> SIRIUS HANDLE
	S5771	**	<b>MANILLA POLARIS</b> POLARIS HANDLE
2	05370900		<b>ÁNGULO DE REENVÍO SUPERIOR</b> UPPER CORNER DRIVE
3	0517078		<b>CAJA DE TRANSMISIÓN</b> GEARBOX
4	130720		<b>COMPÁS LIMITADOR</b> LIMITING FRICTION STAY
5	05373400		<b>ÁNGULO DE REENVÍO INFERIOR</b> LOWER CORNER DRIVE

» **CONFIGURACIÓN** CONFIGURATION 2

1	A0771	**	<b>MANILLA SIRIUS</b> SIRIUS HANDLE
	S5771	**	<b>MANILLA POLARIS</b> POLARIS HANDLE
2	05370900		<b>ÁNGULO DE REENVÍO SUPERIOR</b> UPPER CORNER DRIVE
3	130720		<b>COMPÁS LIMITADOR</b> LIMITING FRICTION STAY
4	0517078		<b>CAJA DE TRANSMISIÓN</b> GEARBOX
5	05373400		<b>ÁNGULO DE REENVÍO INFERIOR</b> LOWER CORNER DRIVE

» **CONFIGURACIÓN** CONFIGURATION 3

1	A1157	**	<b>CREMONA SIRIUS</b> SIRIUS CREMONE
	1135	**	<b>CREMONA LYRA</b> LYRA CREMONE
2	05370900		<b>ÁNGULO DE REENVÍO SUPERIOR</b> UPPER CORNER DRIVE
3	130720		<b>COMPÁS LIMITADOR</b> LIMITING FRICTION STAY
4	05373400		<b>ÁNGULO DE REENVÍO INFERIOR</b> LOWER CORNER DRIVE

► Para H > 1800 mm recomendamos el uso de la configuración 1. For H > 1800 mm the use of configuration 1 is recommended.

## PUNTOS DE CIERRE

### LOCKING POINTS

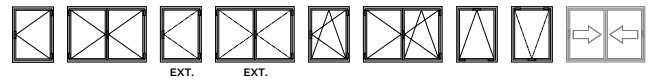

## PUNTO DE CIERRE PARA EL INVERSOR

### LOCKING POINT FOR THE INVERTER

177000

50



ZM INX

Puntos de cierre para Canal 16.

### Punto de cierre para el inversor

- Punto de cierre que se coloca en el inversor en el caso de añadir uno o más puntos de cierre verticales adicionales.
- Se recomienda el uso del punto de cierre para el inversor a partir de 1200 mm de altura de la hoja de la ventana.

### Punto de cierre regulable

- Elemento de marco para punto de cierre con regulación de apriete.

### Punto de cierre oculto

- El punto de cierre oculto se utiliza como punto de cierre suplementario en la hoja pasiva en posición de oscilo y en ambas hojas en posición de practicable, situándose entre las dos bisagras.
- Se recomienda el uso del punto de cierre oculto a partir de 1200 mm de altura de la hoja de la ventana.

### Embellecedor terminal de falleba

- El embellecedor se fija a la hoja para sujetar los extremos libres de las fallebas de transmisión que llevan un remache como punto de cierre adicional.

Ver la sección de « Configuraciones para aperturas practicables ».

Locking points for Groove 16.

### Locking point for the inverter

- Locking point that is placed in the inverter if one or more additional vertical locking points are added.
- It is recommended to use the locking point for the inverter from 1200 mm height of the window sash.

### Adjustable locking point

- A frame part for the locking point with tightness adjustment.

### Hidden locking point

- The hidden locking point is used as a supplementary locking point on the passive sash in the tilt position and on both sashes in the side-hung position, located between the two hinges.
- It is recommended to use the hidden locking point from 1200 mm height of the window sash.

### Rod terminal trim

- The trim is fixed to the sash to hold the free ends of the transmission rods that have a rivet as an additional locking point.

See the section on « Side-hung opening configurations ».

## PUNTO DE CIERRE REGULABLE

### ADJUSTABLE LOCKING POINT

170200

100



ZM INX

## PUNTO DE CIERRE OCULTO

### HIDDEN LOCKING POINT

172500

50



ZM INX

## EMBELLECEDOR TERMINAL DE FALLEBA

### ROD TERMINAL TRIM

0517083

50



ZM

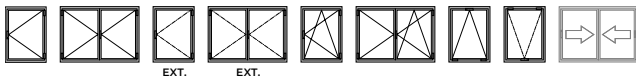

Locking points for Groove 16.

**Slotted locking point**

- The slotted locking point is used to manually attach additional locking points to the transmission rod.

**Encased slotted locking point**

- The encased slotted locking point is used to manually place SOFT type locking points for softer locking hardnesses.

**Rivet locking point**

- The rivet locking point is used to place locking points on the transmission rod through the STAC16 die-cutting machines.

Puntos de cierre para Canal 16.

**Punto de cierre coliso**

- El punto de cierre coliso se utiliza para colocar puntos de cierre adicionales de forma manual.

**Punto de cierre coliso encasquillado**

- El punto de cierre coliso encasquillado se utiliza para colocar puntos de cierre de tipo SOFT de forma manual para durezas de cierre más suaves.

**Punto de cierre remache**

- El punto de cierre remache se utiliza para colocar puntos de cierre en las faldas de transmisión a través de las máquinas troqueladoras STAC16.

**PUNTO DE CIERRE COLISO**  
SLOTTED LOCKING POINT



ZM INX

178000



**PUNTO DE CIERRE COLISO ENCASQUILLADO**  
ENCASED SLOTTED LOCKING POINT



ZM INX

178000C



**PUNTO DE CIERRE REMACHE**  
RIVET LOCKING POINT



ZM

TFS 04 TFS 05

TFS 06

0517002

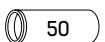

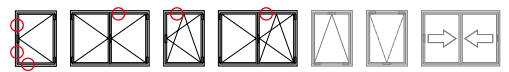

**MICROVENTILACIÓN REGULABLE**  
ADJUSTABLE MICRO-VENTILATION

174401

100



Dispositivo que permite una posición de aireación en la ventana.

Device that allows an aeration position in the window.

- El dispositivo es aplicable en ventanas practicables como oscilobatientes.
- El diseño del cerradero hace que al girar la manilla o la cremona la hoja quede abierta entre 1 y 6 mm.
- El dispositivo sirve para cumplir con las exigencias del Código Técnico de Edificación en cuanto a calidad del aire interior, garantizando la ventilación exigida.

- The device can be used for both side-hung and tilt & turn window openings.
- The design of the keeper makes that when turning the handle or cremone the sash is open between 1 and 6 mm.
- The device serves to meet the requirements of the Technical Building Code regarding indoor air quality, guaranteeing the required ventilation.

**Ensayos (Clase 1)**

**Tests (Class 1)**

- Permeabilidad al aire según la norma UNE-EN 12207: 2017 en posición de microapertura.
- Valores obtenidos según la norma UNE-EN 1026: 2017 realizada en organismo notificado 0370 de acuerdo con el número de informe 09 / 32302792. \*

- Air permeability according to the UNE-EN 12207: 2017 standard in the micro-opening position.
- Values obtained in accordance with the UNE-EN 1026: 2017 standard by notified body 0370 in accordance with report number 09 / 32302792. \*

\* Muestra de referencia: ventana 2 hojas 1230 x 1480 mm.

\* Reference sample: double sash window 1230 x 1480 mm.

■ **APERTURA OSCILOBATIENTE**  
TILT & TURN OPENING

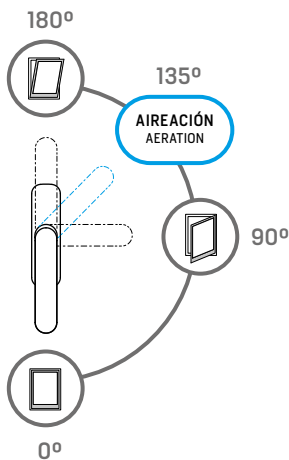

■ **APERTURA PRACTICABLE**  
SIDE-HUNG OPENING

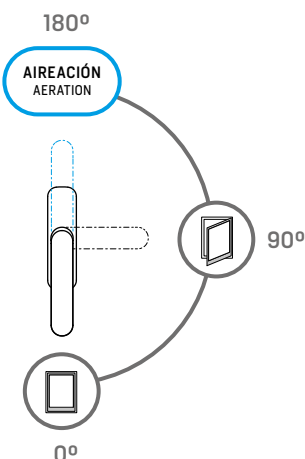

REFERENCIA REFERENCE	DESCUENTO B1 B1 DISCOUNT	L MÍNIMA MINIMUM L	POSICIÓN CERRADERO KEEPER POSITION
170301 $\frac{D}{I}$ ** GRANDE LARGE	L-626	665	128
170302 $\frac{D}{I}$ ** MEDIANO MEDIUM	L-542	582	
170303 $\frac{D}{I}$ ** PEQUEÑO SMALL	L-448	488	
170306 $\frac{D}{I}$ ** MINI	L-370	410	

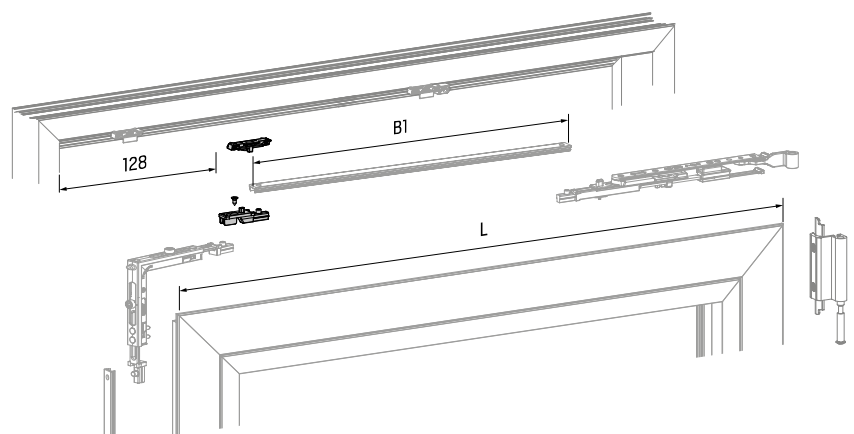

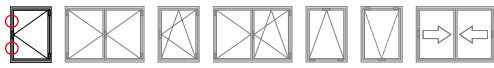

**CONFIGURACIONES PARA APERTURA PRACTICABLE DE 1 HOJA**  
SIDE-HUNG OPENING CONFIGURATIONS FOR SINGLE SASH

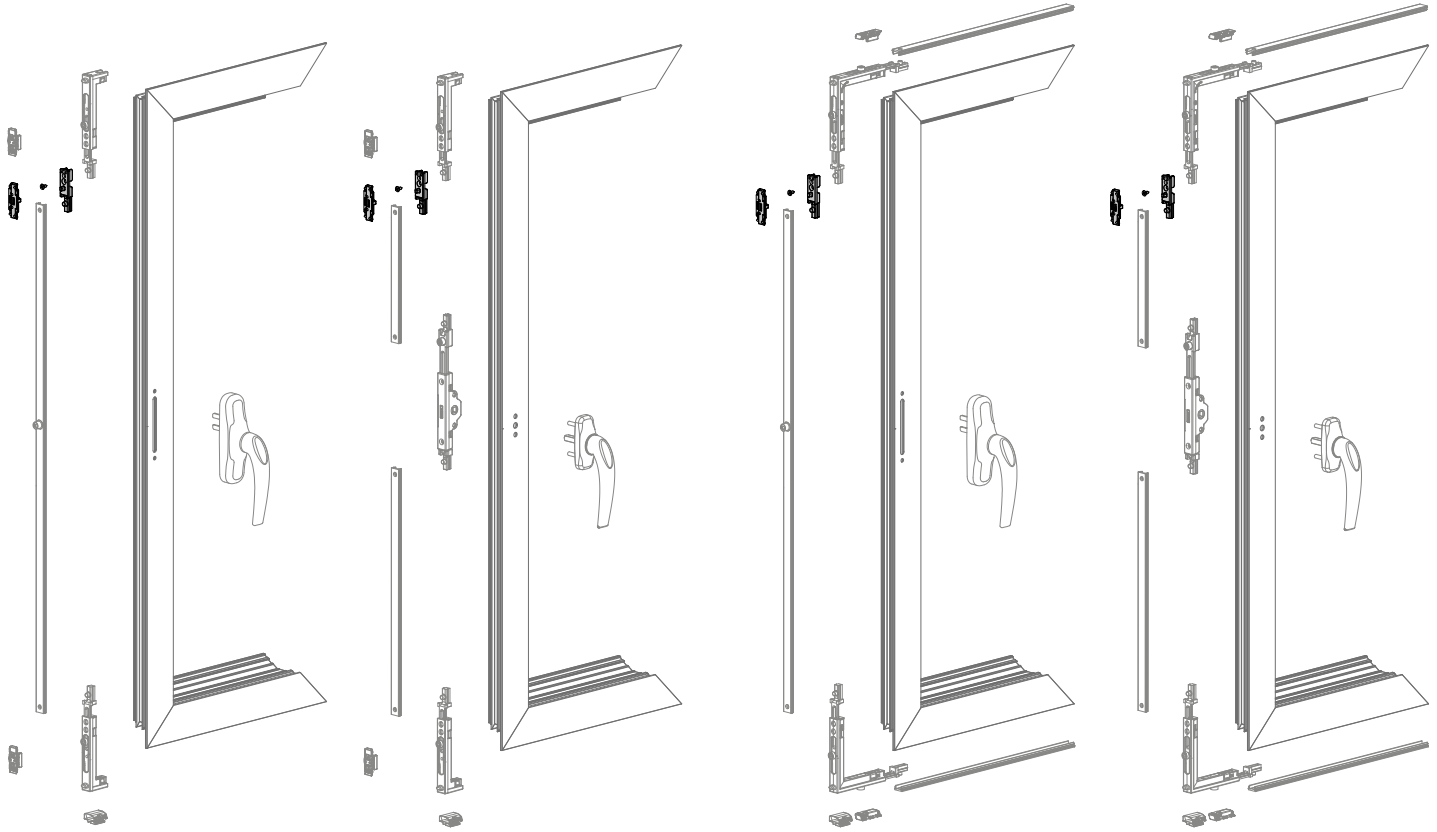

» **APERTURA PRACTICABLE CON CIERRE AL INVERSOR**  
SIDE-HUNG OPENING WITH LOCKING TO INVERTER

**CREMONA CON DOBLE PUNTERO Y REMACHE**  
CREMONE WITH DOUBLE POINTER AND RIVET LOCKING POINT

**MANILLA CON DOBLE PUNTERO Y CAJA DE TRANSMISIÓN**  
HANDLE WITH DOUBLE POINTER AND GEARBOX

» **APERTURA PRACTICABLE CON CIERRE AL MARCO**  
SIDE-HUNG OPENING WITH LOCKING TO FRAME

**CREMONA CON DOBLE ÁNGULO DE REENVÍO Y REMACHE**  
CREMONE WITH DOUBLE CORNER DRIVE AND RIVET LOCKING POINT

**MANILLA CON DOBLE ÁNGULO DE REENVÍO Y CAJA DE TRANSMISIÓN**  
HANDLE WITH DOUBLE CORNER DRIVE AND GEARBOX

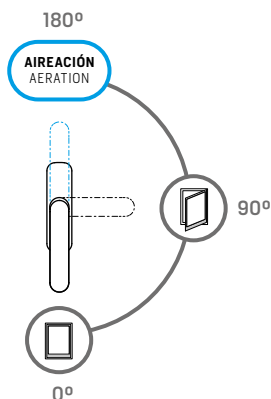

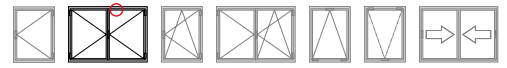

**CONFIGURACIONES PARA APERTURA PRACTICABLE DE 2 HOJAS**  
 SIDE-HUNG OPENING CONFIGURATIONS FOR DOUBLE SASH

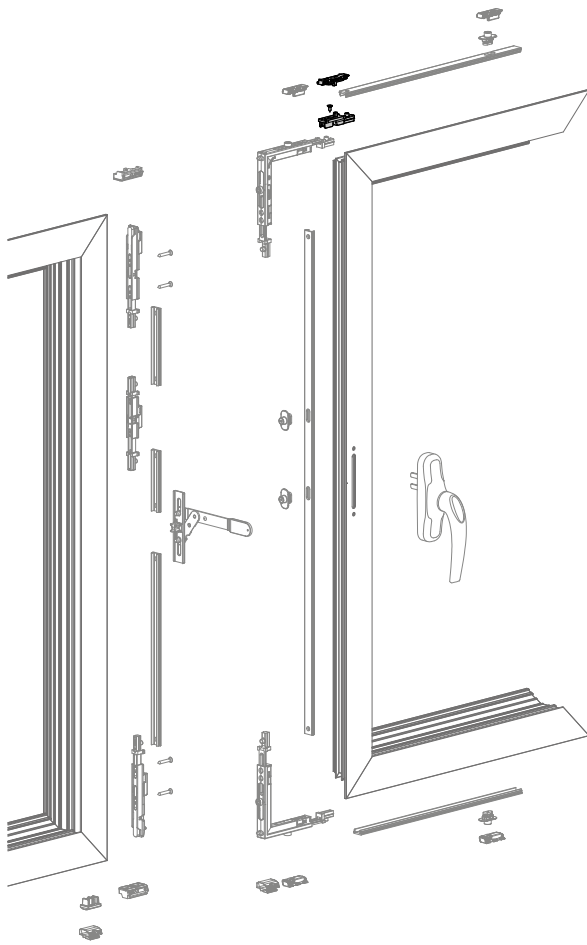

» **APERTURA PRACTICABLE (2 HOJAS)**  
 SIDE-HUNG OPENING (DOUBLE SASH)

**CREMONA CON DOBLE ÁNGULO DE REENVÍO**  
 CREMONE WITH DOUBLE CORNER DRIVE

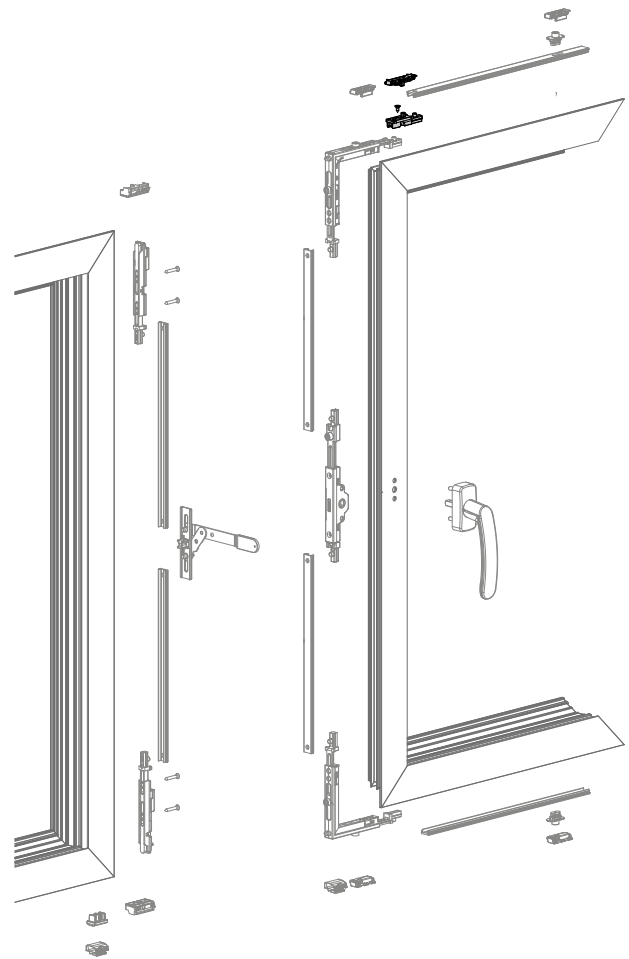

» **APERTURA PRACTICABLE (2 HOJAS)**  
 SIDE-HUNG OPENING (DOUBLE SASH)

**MANILLA CON DOBLE ÁNGULO DE REENVÍO Y CAJA DE TRANSMISIÓN**  
 HANDLE WITH DOUBLE CORNER DRIVE AND GEARBOX

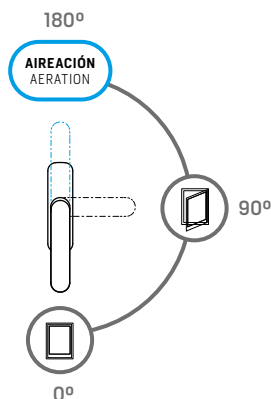



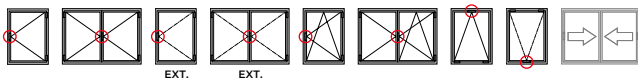

Device that through a handle allows to move the rods and the locking points that open a window.

Mecanismo que accionado por una manilla permite mover las fallebas y los puntos de cierre que abren una ventana.

- The gearboxes are adapted to transmit the movement through a 7 mm spindle.
- They are reversible, therefore they are valid for both right and left hand openings.
- Both gearboxes are equipped with a locking point with a rotating bushing and a stop to limit the travel in the event that they are installed on windows with side-hung, top-hung, bottom-hung or outward opening.

- Las cajas están adaptadas para realizar la transmisión por cuadradillo de 7 mm.
- Son reversibles, por lo tanto son válidas para aperturas tanto a derechas como a izquierdas.
- Ambas cajas de transmisión incorporan un punto de cierre con casquillo giratorio y un tope para limitar el recorrido en caso de que sean montadas en ventanas de apertura practicable, apertura exterior, abatible o proyectante.

**CAJA DE TRANSMISIÓN CON AGUJA DE 15 mm**  
GEARBOX WITH 15 mm BACKSET



ZM AL



7 mm

0517078



**CAJA DE TRANSMISIÓN CON AGUJA DE 35 mm**  
GEARBOX WITH 35 mm BACKSET



ZM AL



7 mm

0517194



■ 15 mm

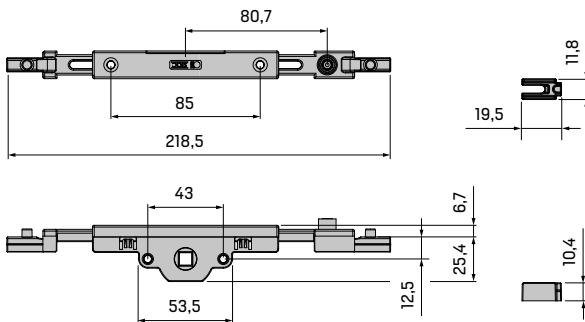

■ 35 mm

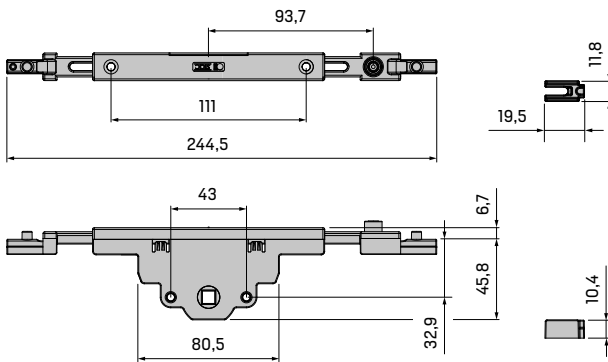

■ **PERFIL DE HOJA VENTANA**  
WINDOW SASH PROFILE

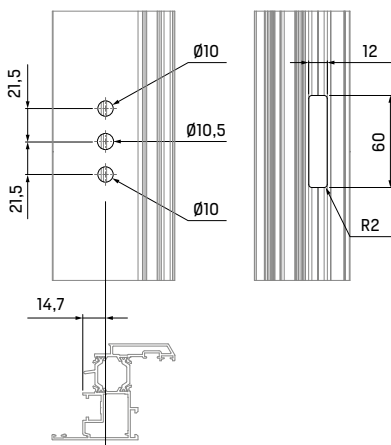

■ **PERFIL DE PUERTA BALCONERA**  
BALCONY DOOR PROFILE

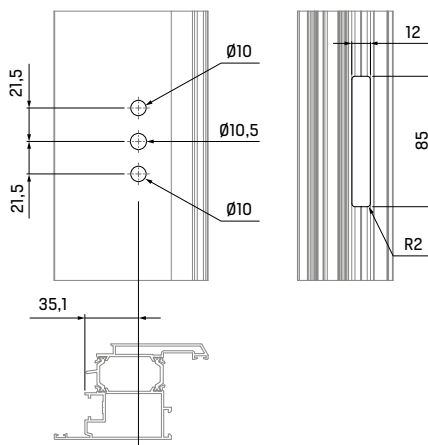

■ **PERFIL DE APERTURA EXTERIOR**  
OUTWARD OPENING PROFILE

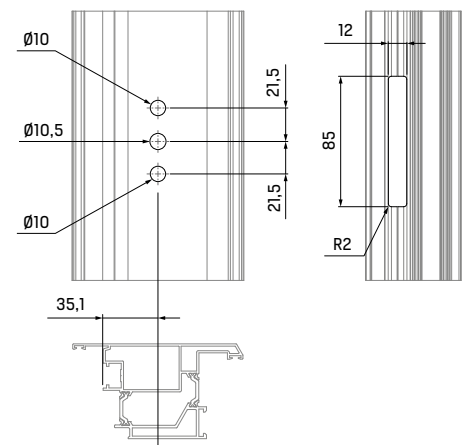

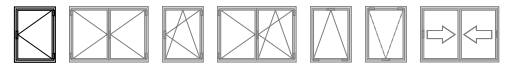

**CIERRE AL INVERSOR CON REMACHES Ó COLISOS (1 HOJA)**

LOCKING TO INVERTER WITH RIVET OR SLOTTED LOCKING POINTS (SINGLE SASH)

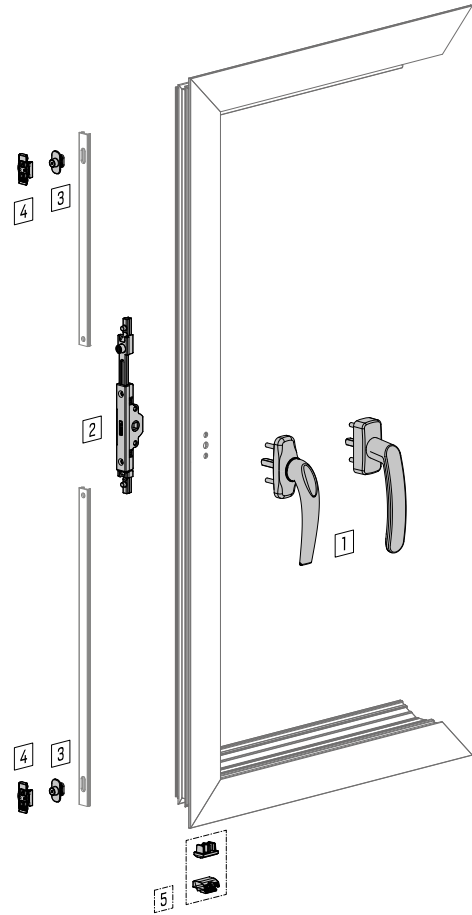
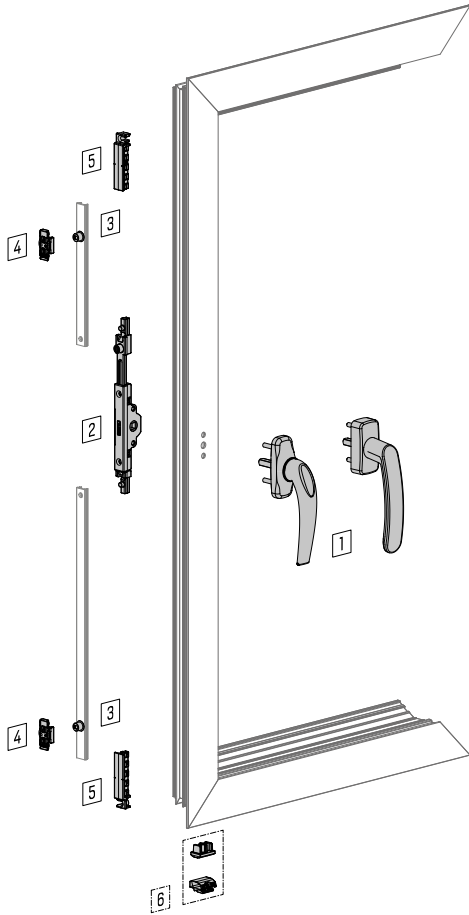

**CON REMACHES**

WITH RIVET LOCKING POINTS



1	<b>MANILLA</b> Ver la sección de « Manillas y cremonas » HANDLE See the chapter on « Handles and cremonas »	
2	<b>0517078 CAJA DE TRANSMISIÓN STAC16</b> STAC16 GEARBOX	20
3	<b>0517002 PUNTO DE CIERRE: REMACHE</b> RIVET LOCKING POINT	50
4	<b>170200 PUNTO DE CIERRE REGULABLE</b> ADJUSTABLE LOCKING POINT	100
5	<b>0517083 EMBELLECEDOR TERMINAL DE FALLEBA</b> ROD TERMINAL TRIM	50
6	<b>0517226 KIT RESBALÓN STAC16</b> STAC16 ANTI-SLIP KIT	50

**CON COLISOS**

WITH SLOTTED LOCKING POINTS



1	<b>MANILLA</b> Ver la sección de « Manillas y cremonas » HANDLE See the chapter on « Handles and cremonas »	
2	<b>0517078 CAJA DE TRANSMISIÓN STAC16</b> STAC16 GEARBOX	20
3	<b>178000 PUNTO DE CIERRE: COLISO</b> SLOTTED LOCKING POINT	100
4	<b>170200 PUNTO DE CIERRE REGULABLE</b> ADJUSTABLE LOCKING POINT	100
5	<b>0517226 KIT RESBALÓN STAC16</b> STAC16 ANTI-SLIP KIT	50

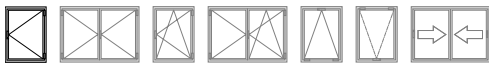

**CIERRE AL INVERSOR CON DOBLE PUNTERO (1 HOJA)**  
LOCKING TO INVERTER WITH DOUBLE POINTER (SINGLE SASH)

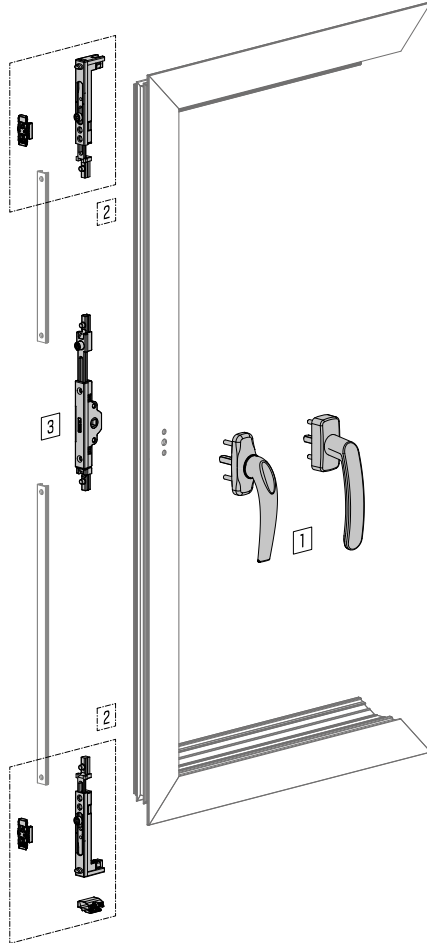

**CON DOBLE PUNTERO**  
WITH DOUBLE POINTER



1 **MANILLA** Ver la sección de « Manillas y cremonas »  
HANDLE See the chapter on « Handles and cremonas »

**PUNTERO STAC16**  
STAC16 POINTER

2 **17K1HCI** **PUNTO DE CIERRE REGULABLE** 50  
ADJUSTABLE LOCKING POINT

**RESBALÓN DE MARCO**  
FRAME ANTI-SLIP

3 **0517078** **CAJA DE TRANSMISIÓN STAC16** 20  
STAC16 GEARBOX



**CIERRE AL INVERSOR CON COLISOS [2 HOJAS]**  
 LOCKING TO INVERTER WITH SLOTTED LOCKING POINTS (DOUBLE SASH)

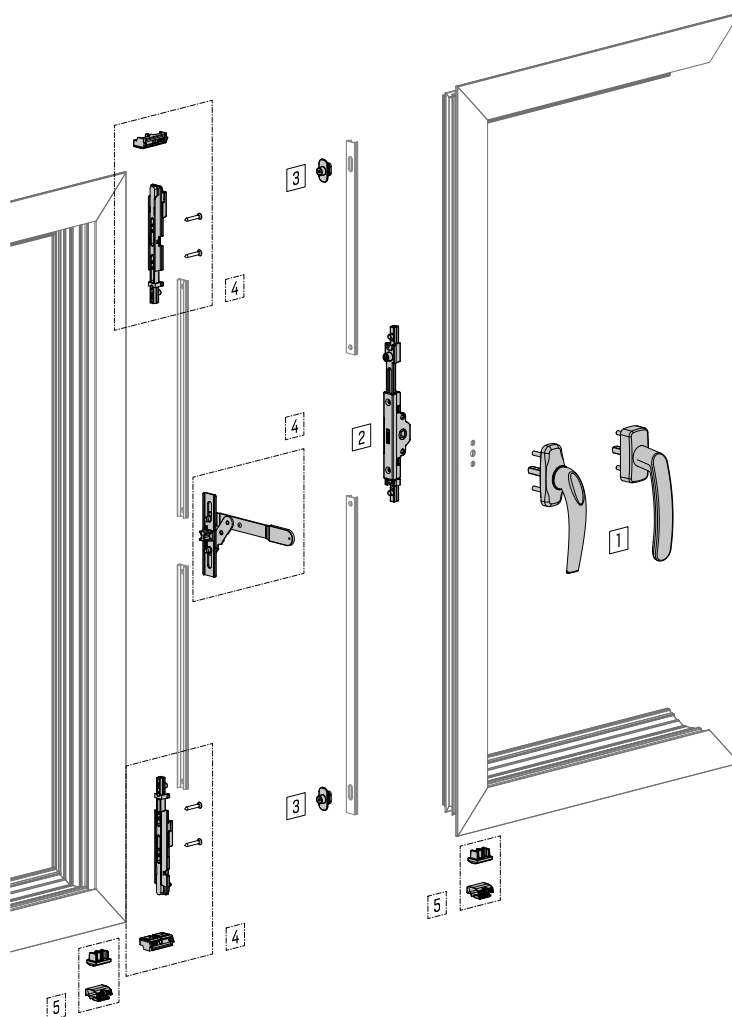

**CON COLISOS**  
 WITH SLOTTED LOCKING POINTS



1 **MANILLA** Ver la sección de « Manillas y cremonas »  
 HANDLE See the chapter on « Handles and cremonas »

2	<b>0517078</b>	<b>CAJA DE TRANSMISIÓN STAC16</b> STAC16 GEARBOX	20
3	<b>178000</b>	<b>PUNTO DE CIERRE: COLISO</b> SLOTTED LOCKING POINT	100
4	<b>171600</b>	<b>KIT PASADOR DE PALANCA BIDIRECCIONAL STAC16</b> STAC16 TWO-WAY SHOOTBOLT LEVER KIT	20
5	<b>0517226</b>	<b>KIT RESBALÓN STAC16</b> STAC16 ANTI-SLIP KIT	50

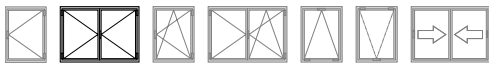

**CIERRE AL INVERSOR CON DOBLE PUNTERO (2 HOJAS)**  
LOCKING TO INVERTER WITH DOUBLE POINTER (DOUBLE SASH)

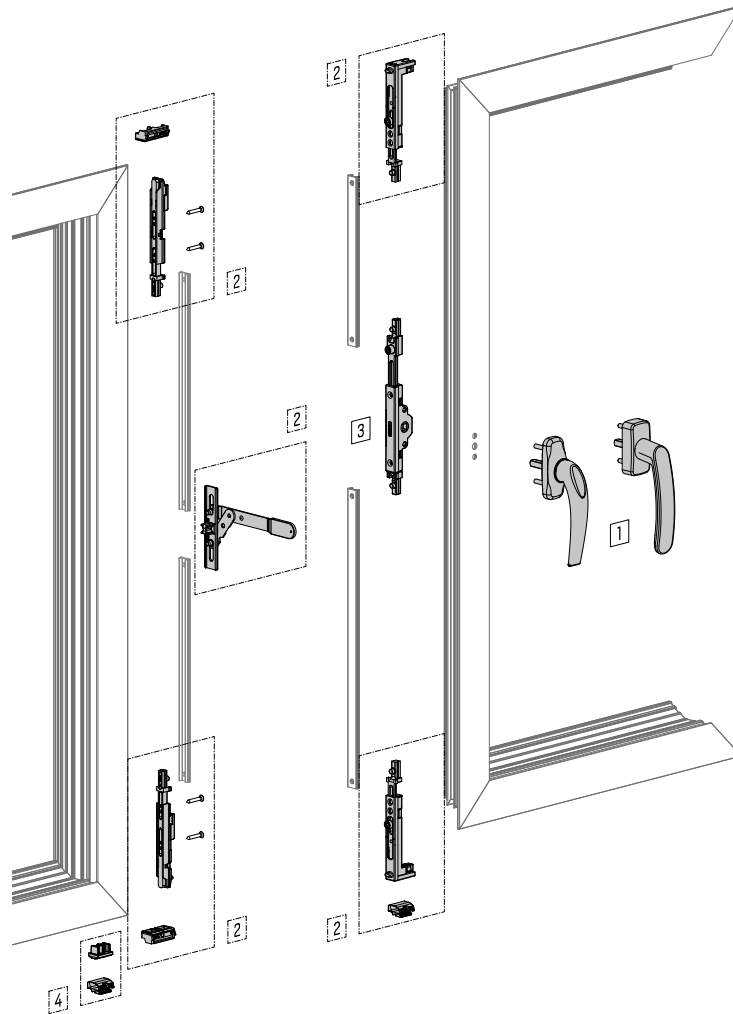

**CON DOBLE PUNTERO**  
WITH DOUBLE POINTER



- 1 **MANILLA** Ver la sección de « Manillas y cremonas »  
HANDLE See the chapter on « Handles and cremonas »

**PUNTERO STAC16**  
STAC16 POINTER

- 2 **17K2HCI** **PUNTO DE CIERRE REGULABLE**  
ADJUSTABLE LOCKING POINT

**RESBALÓN DE MARCO**  
FRAME ANTI-SLIP

**KIT PASADOR DE PALANCA BIDIRECCIONAL STAC16**  
STAC16 TWO-WAY SHOOTBOLT LEVER KIT

- 3 **0517078** **CAJA DE TRANSMISIÓN STAC16** 20  
STAC16 GEARBOX

- 4 **0517226** **KIT RESBALÓN STAC16** 50  
STAC16 ANTI-SLIP KIT

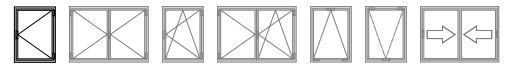

**CIERRE AL MARCO CON DOBLE ÁNGULO DE REENVÍO Y REMACHES Ó COLISOS (1 HOJA)**  
LOCKING TO FRAME WITH DOUBLE CORNER DRIVE AND RIVET OR SLOTTED LOCKING POINTS (SINGLE SASH)

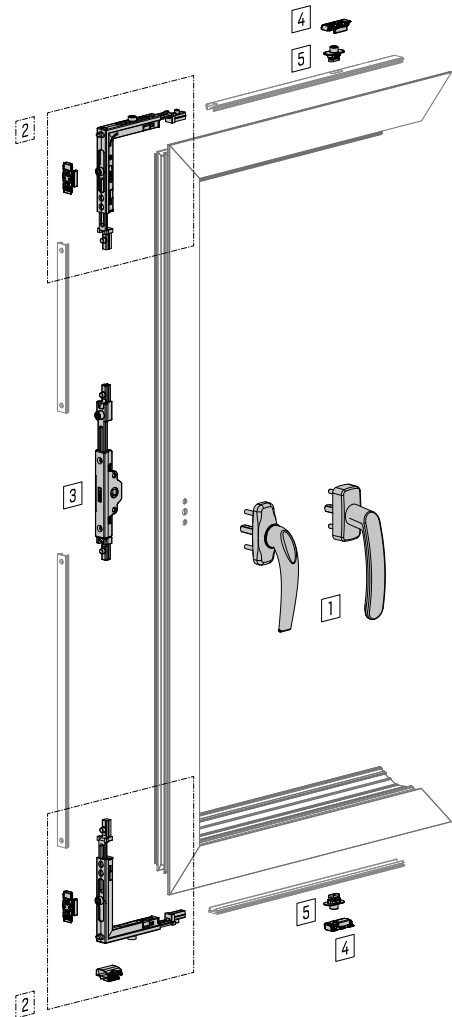
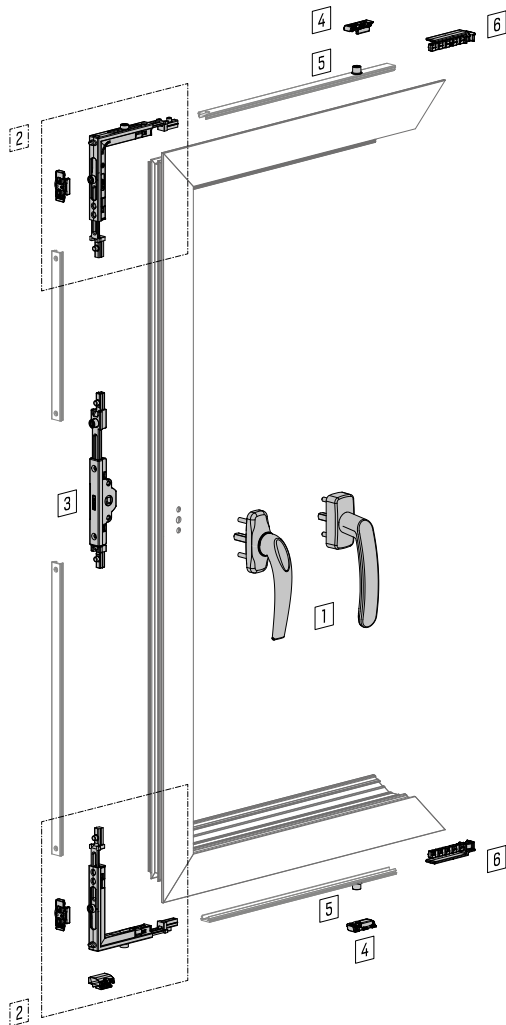

**CON DOBLE ÁNGULO DE REENVÍO Y REMACHES**  
WITH DOUBLE CORNER DRIVE AND RIVET LOCKING POINTS



1 **MANILLA** Ver la sección de « Manillas y cremonas »  
HANDLE See the chapter on « Handles and cremones »

	<b>ÁNGULO DE REENVÍO STAC16</b> STAC16 CORNER DRIVE	
2	<b>17K1HCM</b> <b>PUNTO DE CIERRE REGULABLE</b> ADJUSTABLE LOCKING POINT	1
	<b>RESBALÓN DE MARCO</b> FRAME ANTI-SLIP	
3	<b>0517078</b> <b>CAJA DE TRANSMISIÓN STAC16</b> STAC16 GEARBOX	20
4	<b>170200</b> <b>PUNTO DE CIERRE REGULABLE</b> ADJUSTABLE LOCKING POINT	100
5	<b>0517002</b> <b>PUNTO DE CIERRE: REMACHE</b> RIVET LOCKING POINT	50
6	<b>0517083</b> <b>EMBELLECEDOR TERMINAL DE FALLEBA</b> ROD TERMINAL TRIM	50

**CON DOBLE ÁNGULO DE REENVÍO Y COLISOS**  
WITH DOUBLE CORNER DRIVE AND SLOTTED LOCKING POINTS



1 **MANILLA** Ver la sección de « Manillas y cremonas »  
HANDLE See the chapter on « Handles and cremones »

	<b>ÁNGULO DE REENVÍO STAC16</b> STAC16 CORNER DRIVE	
2	<b>17K1HCM</b> <b>PUNTO DE CIERRE REGULABLE</b> ADJUSTABLE LOCKING POINT	1
	<b>RESBALÓN DE MARCO</b> FRAME ANTI-SLIP	
3	<b>0517078</b> <b>CAJA DE TRANSMISIÓN STAC16</b> STAC16 GEARBOX	20
4	<b>170200</b> <b>PUNTO DE CIERRE REGULABLE</b> ADJUSTABLE LOCKING POINT	100
5	<b>178000</b> <b>PUNTO DE CIERRE: COLISO</b> SLOTTED LOCKING POINT	100

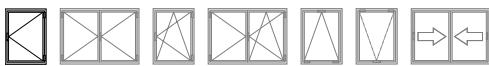

**CIERRE AL MARCO CON DOBLE ÁNGULO DE REENVÍO Y REMACHES Ó COLISOS (2 HOJAS)**  
LOCKING TO FRAME WITH DOUBLE CORNER DRIVE AND RIVET OR SLOTTED LOCKING POINTS (DOUBLE SASH)

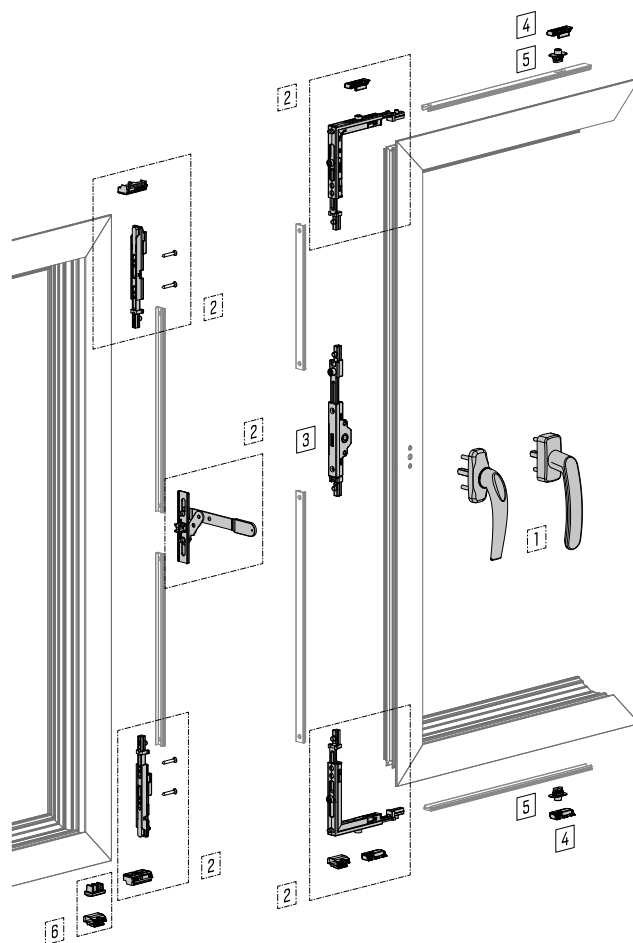
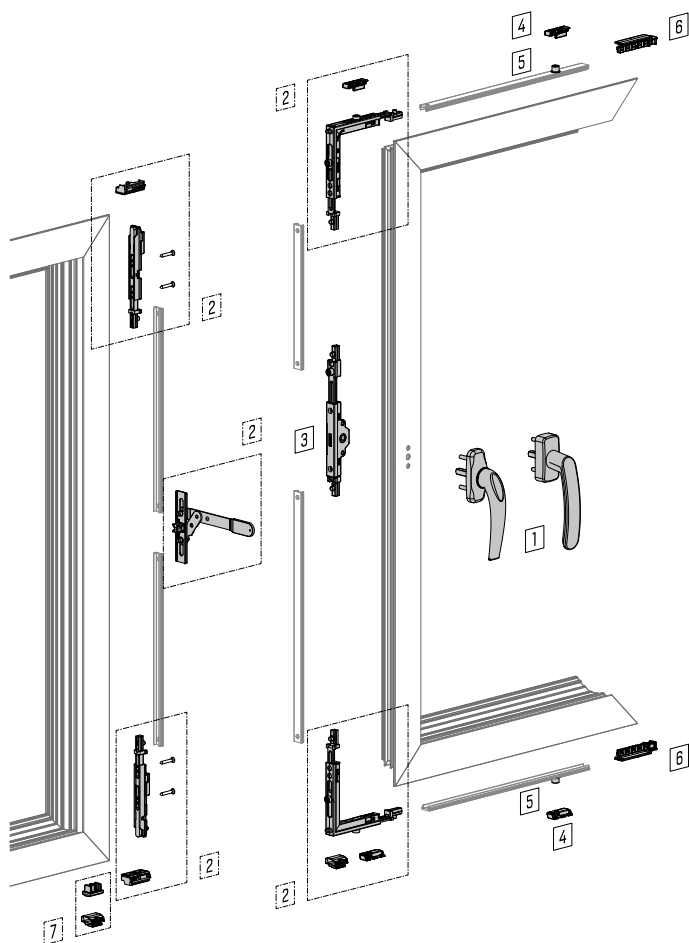

**CON DOBLE ÁNGULO DE REENVÍO Y REMACHES**  
WITH DOUBLE CORNER DRIVE AND RIVET LOCKING POINTS



1 **MANILLA** Ver la sección de « Manillas y cremonas »  
HANDLE See the chapter on « Handles and cremones »

**ÁNGULO DE REENVÍO STAC16**  
STAC16 CORNER DRIVE

**PUNTO DE CIERRE REGULABLE**  
ADJUSTABLE LOCKING POINT

2 **17K2HCM** **RESBALÓN DE MARCO**  
FRAME ANTI-SLIP 1

**KIT PASADOR DE PALANCA BIDIRECCIONAL STAC16**  
STAC16 TWO-WAY SHOOTBOLT LEVER KIT

3 **0517078** **CAJA DE TRANSMISIÓN STAC16**  
STAC16 GEARBOX 20

4 **170200** **PUNTO DE CIERRE REGULABLE**  
ADJUSTABLE LOCKING POINT 100

5 **0517002** **PUNTO DE CIERRE: REMACHE**  
RIVET LOCKING POINT 50

6 **0517083** **EMBELLECEDOR TERMINAL DE FALLEBA**  
ROD TERMINAL TRIM 50

7 **0517226** **KIT RESBALÓN STAC16**  
STAC16 ANTI-SLIP KIT 50

**CON DOBLE ÁNGULO DE REENVÍO Y COLISOS**  
WITH DOUBLE CORNER DRIVE AND SLOTTED LOCKING POINTS



1 **MANILLA** Ver la sección de « Manillas y cremonas »  
HANDLE See the chapter on « Handles and cremones »

**ÁNGULO DE REENVÍO STAC16**  
STAC16 CORNER DRIVE

**PUNTO DE CIERRE REGULABLE**  
ADJUSTABLE LOCKING POINT

2 **17K2HCM** **RESBALÓN DE MARCO**  
FRAME ANTI-SLIP 1

**KIT PASADOR DE PALANCA BIDIRECCIONAL STAC16**  
STAC16 TWO-WAY SHOOTBOLT LEVER KIT

3 **0517078** **CAJA DE TRANSMISIÓN STAC16**  
STAC16 GEARBOX 20

4 **170200** **PUNTO DE CIERRE REGULABLE**  
ADJUSTABLE LOCKING POINT 100

5 **178000** **PUNTO DE CIERRE: COLISO**  
SLOTTED LOCKING POINT 100

6 **0517226** **KIT RESBALÓN STAC16**  
STAC16 ANTI-SLIP KIT 50

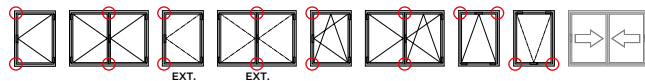

**ÁNGULO DE REENVÍO INOX SUPERIOR**  
UPPER STAINLESS STEEL CORNER DRIVE

05370900



ZM INX

AC



Ángulos de reenvío en acero inoxidable para perfiles con Canal 16.

- Los ángulos se utilizan tanto en aperturas practicables como oscilobatientes.

**Ángulo de reenvío superior**

- El ángulo superior posee dos puntos de cierre encaquillados para mayor suavidad de cierre. Este ángulo también se puede utilizar en aperturas abatibles y proyectantes.

**Ángulo de reenvío inferior**

- El ángulo inferior posee un punto de cierre frontal encaquillado y una seta para realizar el basculamiento en oscilo y que sirve también como antielevarción y como punto de cierre de seguridad.

Stainless steel corner drives for profiles with Groove 16.

- Corner drives are used in both side-hung and tilt & turn openings.

**Upper corner drive**

- The upper stainless steel corner drive has two encased locking points for a smoother closing. This corner drive can also be used for top-hung and bottom-hung openings.

**Lower corner drive**

- The lower stainless steel corner drive has a front encased locking point and a mushroom for tilt & turn opening, which is also used as an anti-lifting device and security locking point.

**ÁNGULO DE REENVÍO INOX INFERIOR**  
LOWER STAINLESS STEEL CORNER DRIVE

05373400



ZM INX

AC

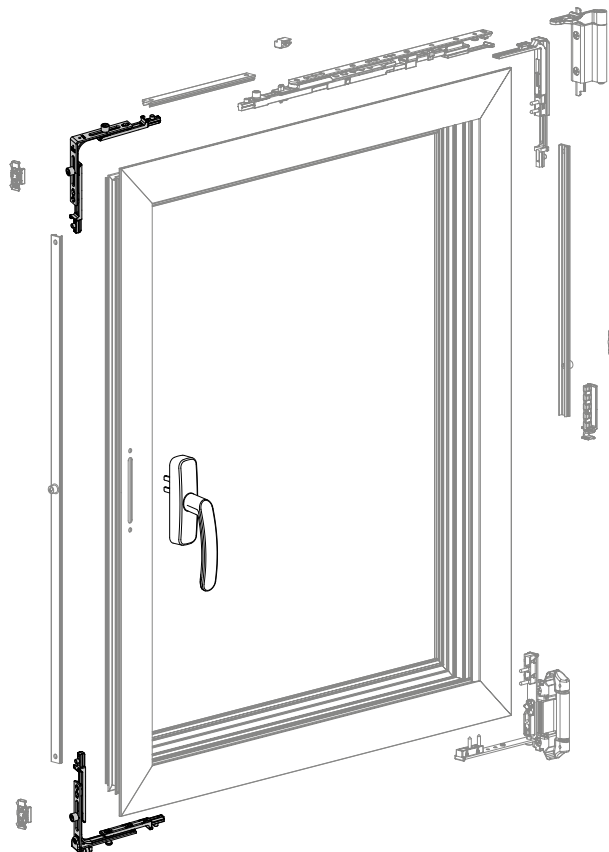



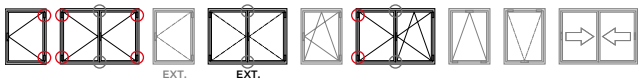

Adjustable hinges for passive sash of tilt & turn windows.

- The hinges allow to obtain the same adjustments as in the active sash.
- The hinges are reversible but easily interchangeable from left-hand to right-hand.
- The hinges can be installed on both active and passive sash side-hung windows to obtain the same adjustments as on tilt & turn windows.

Bisagras regulables para hoja pasiva de ventanas oscilobatientes.

- Las bisagras permiten obtener las mismas regulaciones que en la hoja activa.
- Las bisagras son reversibles pero intercambiables de apertura izquierdas a derechas fácilmente.
- Las bisagras se pueden instalar en ventanas de apertura practicable tanto en hoja activa como en pasiva para obtener las mismas regulaciones que en oscilo.

#### Passive sash corner drive

- The stainless steel corner drive has a top / bottom encased locking point which contributes to a smooth closing operation to the passive sash and can be combined with the two-way lever.

#### Ángulo de reenvío para hoja pasiva

- El ángulo de reenvío en acero inoxidable posee un punto de cierre encasquado superior / inferior para aportar suavidad al cierre de la hoja pasiva y se puede combinar con la palanca bidireccional.

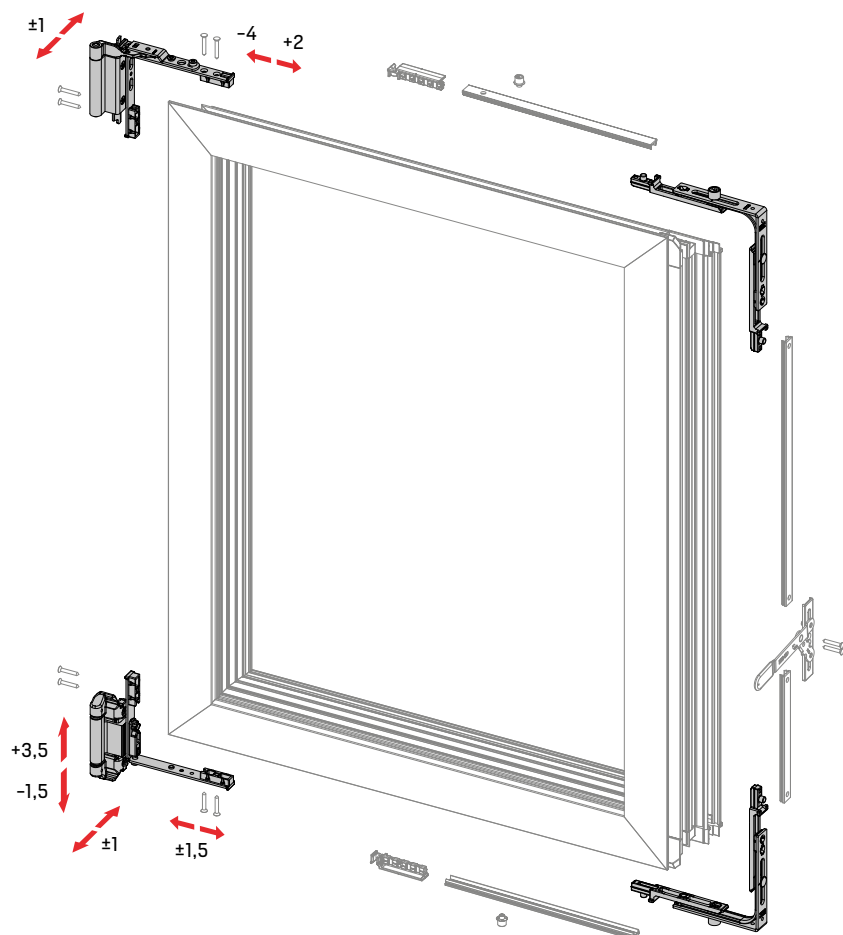

#### KIT DE BISAGRAS STAC16 STAC16 HINGE KIT



**	D	**
1714	I	



#### ÁNGULO DE REENVÍO INOX PARA HOJA PASIVA PASSIVE SASH STAINLESS STEEL CORNER DRIVE



05374700
----------



#### APERTURAS OSCILOBATIENTES

Es necesario atornillar siempre la pala marco y colocar la pieza de refuerzo en la bisagra superior para:

L > 1000 mm y H > 1800 mm

#### TILT & TURN OPENINGS

It is always necessary to screw on the frame leaf and place the reinforcement piece on the upper hinge to:

L > 1000 mm and H > 1800 mm.

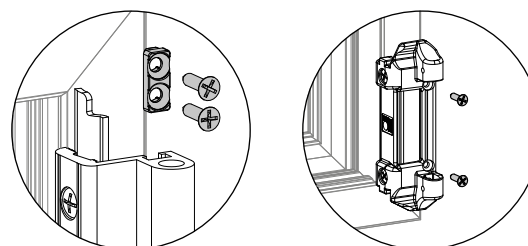

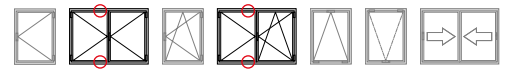

**KIT CLIP RETENEDOR**  
RETAINING CLIP KIT

0517047

50



ZM INX

Mecanismo para mantener bloqueada la hoja pasiva cuando está cerrada.

- El elemento de marco es automontable y admite regulación.
- El clip retenedor se desactiva tirando de la hoja.
- Es necesario instalar el tope antielevación de dos hojas al utilizar el clip retenedor.

A retaining mechanism to keep the passive sash locked when closed.

- The frame element is self assembled and can be adjusted.
- The retaining clip is de-activated by pulling on the sash.
- It is necessary to install the double sash anti-lift stop when using the retaining clip.

**TOPE ANTIELEVACIÓN**  
ANTI-LIFT STOP

0517091

50



ZM

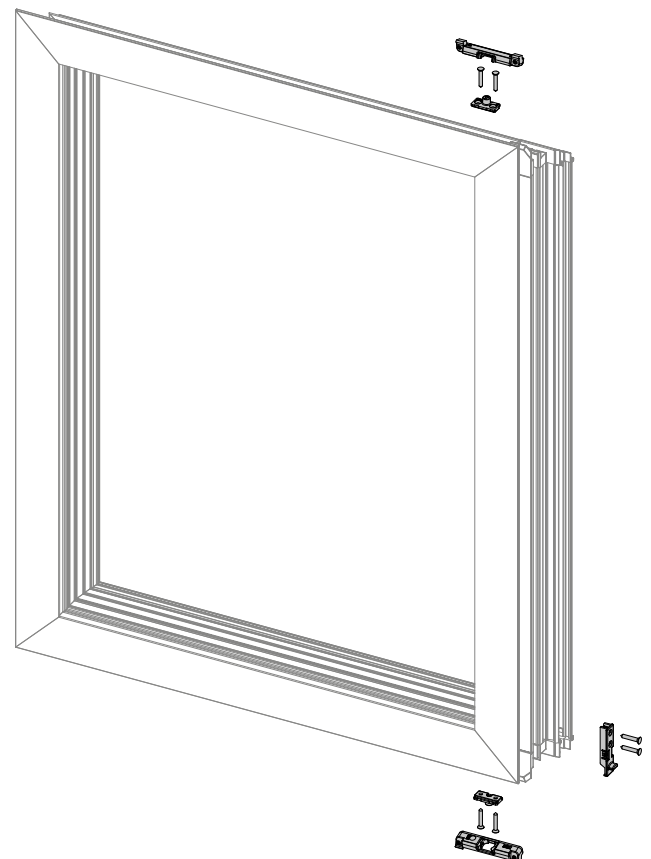

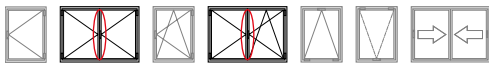

## PASADORES DE PALANCA BIDIRECCIONALES

### TWO-WAY SHOOTBOLT LEVERS

A locking kit for the passive sash by way of a two-way shootbolt lever.

- Comprising of two terminals connected to a lever using rods.
- By activating one lever the terminals are opened or closed.
- The terminals of the kit incorporate locking points with a  $\pm 2.2$  mm tightening adjustment and an anti-lifting projection on the lower terminal.

Kit de cierre para la hoja pasiva mediante pasador de palanca bidireccional.

- Se compone de dos terminales conectados a una palanca mediante fallebas.
- Accionando una sola palanca se abren o cierran los dos terminales.
- Los terminales del kit incorporan puntos de cierre con regulación en apriete de  $\pm 2,2$  mm y un resalte anti-elevación en el terminal inferior.

## KIT PASADOR DE PALANCA BIDIRECCIONAL

### TWO-WAY SHOOTBOLT LEVER KIT



ZM INX

PA

171600

20



## PASADOR DE PALANCA BIDIRECCIONAL

### TWO-WAY SHOOTBOLT LEVER



ZM INX

05171668

20

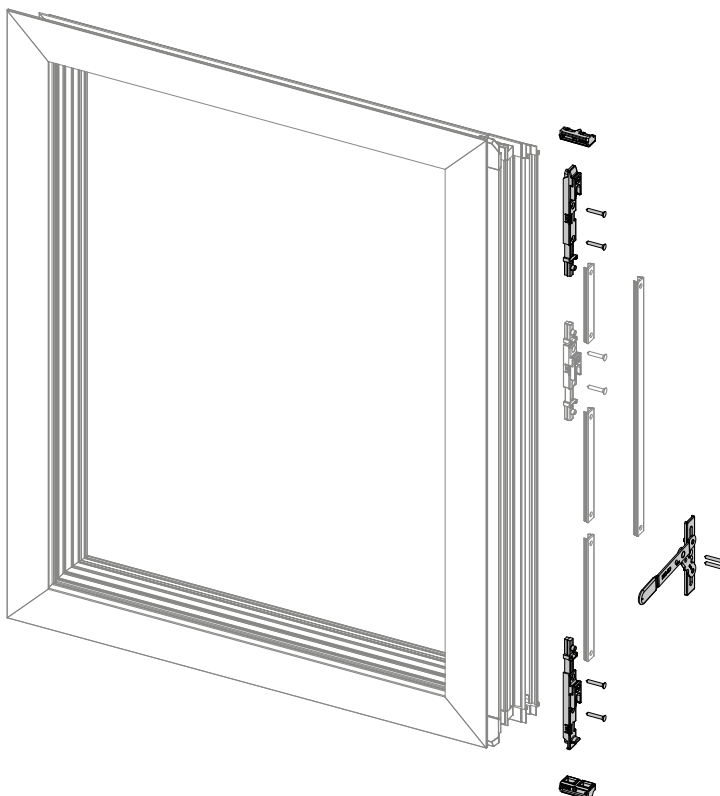

## FALLEBAS DE TRANSMISIÓN STAC16

STAC16 TRANSMISSION RODS

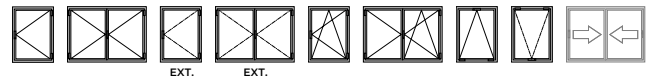

### FALLEBA DE TRANSMISIÓN STAC16

STAC16 TRANSMISSION ROD

059234



200 m



PA

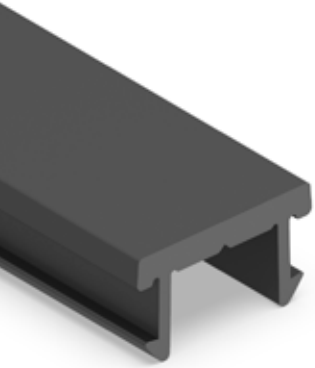

Fallebas de transmisión y clip de poliamida para perfiles con Canal 16.

- Las fallebas STAC16 se adaptan a canales de 16 mm con o sin pestañas.

- **Para Canal 16 con pestañas:**

La falleba posee dos patillas flexibles que permiten el clipaje directo con el canal.

- **Para Canal 16 sin pestañas:**

- Las fallebas permiten la instalación de múltiples puntos de cierre adicionales en el lugar deseado.

- Las fallebas se mecanizan con las máquinas de troquelado STAC16.

Transmission rods and polyamide clip for profiles with Groove 16.

- The STAC16 operating rods adapt to the 16 mm groove with or without flanges.

- **For Groove 16 with flanges:**

The transmission rod has two flexible legs that permit a direct clipping with the groove.

- **For Groove 16 without flanges:**

- The transmission rods allow the installation of multiple additional locking points at the desired location.

- The rods are machined on STAC16 die-cutting machines.

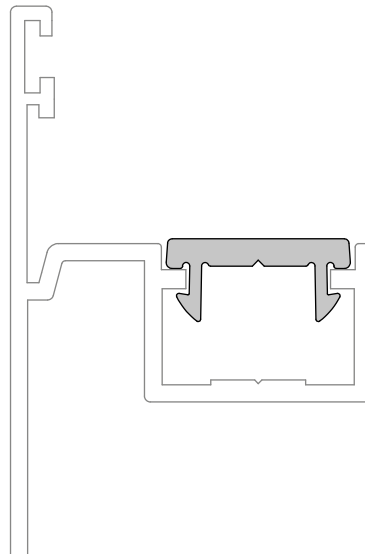
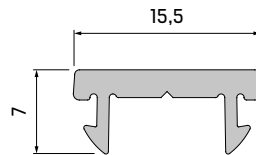

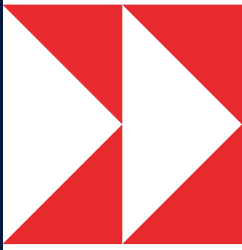

# 19

## HERRAJE ANODIZADO ANODISED HARDWARE

- 368 **Herraje anodizado**  
Anodised hardware
- 369 **Bisagras anodizadas**  
Anodised hinges
- 370 **Manillas y cremonas anodizadas**  
Anodised handles & cremones
- 371 **Manillas de puerta anodizadas**  
Anodised door handles
- 371 **Embellecedores de cilindro anodizados**  
Anodised cylinder cover plates
- 372 **Tiradores de puerta anodizados**  
Anodised door pull handles
- 373 **Bisagras oscilobatientes CLX anodizadas**  
Anodised CLX tilt & turn hinges
- 373 **Kits oscilobatientes CLX anodizados**  
Anodised CLX tilt & turn kits
- 374 **Manillas de fachada anodizadas**  
Anodised facade handles
- 374 **Cierres de embutir anodizados**  
Anodised recessed handles





En el catálogo existen diferentes productos que son susceptibles de ser anodizados. Estos productos están señalados en el catálogo con el icono **ANODIC**, indicando que un producto puede pedirse en cualquiera de los acabados anodizados disponibles.

#### » Anodizado 81

Las referencias de productos con terminación 81 corresponden con los siguientes acabados anodizados:

- Anodizado natural mate
- Anodizado inox mate

#### » Anodizado 82

Las referencias de los tiradores para puerta TAU para también están disponibles con terminación 82 que corresponde con el acabado:

- Anodizado acier grata

#### » Kits oscilobatientes

En los kits de apertura oscilobatiente el acabado anodizado depende de la cremone y las bisagras seleccionadas en el kit. Las referencias se generan añadiendo « 81 » como acabado. En el caso particular de kits con bisagras anodizadas es necesario indicar la mano de apertura: « D » para aperturas a derechas o « I » para aperturas a izquierdas.

S1132	D	81	S
	I		

In the catalogue there are different products that can be supplied with an anodised finish. These products are indicated in the catalogue with the **ANODIC** icon, indicating that a product can be ordered in any of the available anodised finishes.

#### » Anodised 81

Product references with finish 81 correspond to the following anodised finishes:

- Natural matt anodised
- Inox matt anodised

#### » Anodised 82

The TAU door pull handle references are also available with finish 82, which corresponds to the finish:

- Acier grata anodised

#### » Tilt & turn kits

The anodised finish of the tilt & turn kits depends on the cremone and the hinges selected in the kit. The references are generated by adding « 81 » as the finish. In the particular case of kits with anodised hinges, it is necessary to indicate the opening hand: « D » for right-hand opening or « I » for left-hand opening.

S1132	D	81	S
	I		







A continuación se muestran las referencias que están disponibles con acabado anodizado, para ello debe añadir la terminación «**81**» como acabado. En el caso de los kits oscilobatientes el acabado anodizado depende de las bisagras y la cremone y en el caso particular de los kits con bisagras anodizadas es necesario indicar la mano de apertura: «**D**» para aperturas a derechas o «**I**» para aperturas a izquierdas.

Puede obtener más información sobre cada referencia en el capítulo correspondiente al producto en este Catálogo General de Herraje.



Below are shown all the product references that are available with an anodised finish, for this you must add the termination «**81**» as finish. In the case of tilt & turn opening kits the anodised finish depends on the hinges and the cremone and in the particular case of kits with anodised hinges it is necessary to indicate the opening hand: «**D**» for right-hand opening or «**I**» for left-hand opening.

You can obtain more information on each reference in the chapter corresponding to the product in this Hardware General Catalogue.



» **BISAGRAS HINGES**



		<b>REF.</b>	<b>PAG.</b>						
	<b>BISAGRA ACRUX 2 PALAS</b> 2-LEAF ACRUX HINGE	<table border="1"> <tr> <td rowspan="2">010</td> <td>D</td> <td rowspan="2">81</td> </tr> <tr> <td>I</td> </tr> </table>	010	D	81	I	28		
010	D	81							
	I								
	<b>BISAGRA ACRUX 3 PALAS</b> 3-LEAF ACRUX HINGE	<table border="1"> <tr> <td>P010</td> <td>D</td> <td>81</td> </tr> </table>	P010	D	81	28			
P010	D	81							
	<b>BISAGRA ARIES T 2 PALAS</b> 2-LEAF ARIES T HINGE	<table border="1"> <tr> <td rowspan="4">010T2</td> <td>60</td> <td rowspan="4">81</td> </tr> <tr> <td>66</td> </tr> <tr> <td>80</td> </tr> <tr> <td>93</td> </tr> </table>	010T2	60	81	66	80	93	32
010T2	60	81							
	66								
	80								
	93								
	<b>BISAGRA ARIES T 3 PALAS</b> 3-LEAF ARIES T HINGE	<table border="1"> <tr> <td rowspan="4">010T3</td> <td>60</td> <td rowspan="4">81</td> </tr> <tr> <td>66</td> </tr> <tr> <td>80</td> </tr> <tr> <td>93</td> </tr> </table>	010T3	60	81	66	80	93	33
010T3	60	81							
	66								
	80								
	93								
	<b>BISAGRA NORMA FAST</b> NORMA FAST HINGE	<table border="1"> <tr> <td rowspan="2">025</td> <td>D</td> <td rowspan="2">81</td> </tr> <tr> <td>I</td> </tr> </table>	025	D	81	I	48		
025	D	81							
	I								
	<b>BISAGRA HÉRCULES</b> HERCULES HINGE	<table border="1"> <tr> <td>C0170</td> <td>81</td> </tr> </table>	C0170	81	51				
C0170	81								

» **MANILLAS Y CREMONAS** HANDLES AND CREMONES



		REF.	PAG.
	<b>CREMONA PRACTICABLE SIRIUS</b> (AP. DERECHAS) SIRIUS SIDE-HUNG CREMONE (RIGHT-HAND OPENING)	A0790 81	62
	<b>CREMONA PRACTICABLE SIRIUS</b> (AP. IZQUIERDAS) SIRIUS SIDE-HUNG CREMONE (LEFT-HAND OPENING)	A0791 81	62
	<b>CREMONA A LA FRANCESA SIRIUS</b> (PALA CORTA) SIRIUS FRENCH STYLE CREMONE (SHORT LEVER)	A0794 81	62
	<b>CREMONA A LA FRANCESA SIRIUS</b> (PALA LARGA) SIRIUS FRENCH STYLE CREMONE (LONG LEVER)	P0794 81	62
	<b>CREMONA OSCIOBATIENTE SIRIUS</b> (CON FUNDA DE TRANSMISIÓN) SIRIUS TILT & TURN CREMONE (WITH TRANSMISSION COVER)	A1154 81	64
	<b>CREMONA OSCIOBATIENTE SIRIUS</b> (SIN FUNDA DE TRANSMISIÓN) SIRIUS TILT & TURN CREMONE (WITHOUT TRANSMISSION COVER)	A1157 81	64
	<b>MANILLA POLARIS</b> POLARIS HANDLE	S5771 81	70
	<b>MANILLA PARA APERTURA EXTERIOR POLARIS</b> (7 x 64 mm) POLARIS OUTWARD OPENING HANDLE (7 x 64 mm)	S5775 81	70
	<b>MANILLA PARA APERTURA EXTERIOR POLARIS</b> (7 x 75 mm) POLARIS OUTWARD OPENING HANDLE (7 x 75 mm)	T5775 81	70



» <b>MANILLONES</b> PULL HANDLES		<b>REF.</b>	<b>PAG.</b>	
	<b>MANILLÓN ATRIA CON LLAVE</b> ATRIA PULL HANDLE WITH KEY	2311	81	87
	<b>JUEGO DE MANILLONES ATRIA CON LLAVE</b> ATRIA PULL HANDLE SET WITH KEY	2313	81	88
	<b>MANILLÓN ATRIA SIN LLAVE</b> ATRIA PULL HANDLE WITHOUT KEY	2312	81	87
	<b>JUEGO DE MANILLONES ATRIA SIN LLAVE</b> ATRIA PULL HANDLE SET WITHOUT KEY	2314	81	88

» <b>MANILLAS DE PUERTA</b> DOOR HANDLES		<b>REF.</b>	<b>PAG.</b>	
	<b>JUEGO DE MANILLAS POLARIS</b> POLARIS HANDLE SET	05182	81	111
	<b>MANILLA SIMPLE POLARIS</b> POLARIS SIMPLE HANDLE	05183	81	111
	<b>EMBELLECEDOR DE CILINDRO SLIM</b> SLIM CYLINDER COVER PLATE	0508053	81	124

» **TIRADORES DE PUERTA** DOOR PULL HANDLES

		REF.	PAG.		
	<b>TIRADOR RECTO TAU</b> TAU STRAIGHT PULL HANDLE	052421 <table border="1"><tr><td>81</td></tr><tr><td>82</td></tr></table>	81	82	119
81					
82					
	<b>KIT DE EMBELLECEDORES TIRADOR RECTO TAU</b> TAU STRAIGHT PULL HANDLE COVER KIT	052431 <table border="1"><tr><td>81</td></tr><tr><td>82</td></tr></table>	81	82	119
81					
82					
	<b>TIRADOR RECTO TAU + KIT DE EMBELLECEDORES</b> TAU STRAIGHT PULL HANDLE + COVER KIT	052411 <table border="1"><tr><td>81</td></tr><tr><td>82</td></tr></table>	81	82	119
81					
82					
	<b>TIRADOR DESPLAZADO IZQUIERDO TAU</b> TAU LEFT OFFSET PULL HANDLE	052422 <table border="1"><tr><td>81</td></tr><tr><td>82</td></tr></table>	81	82	120
81					
82					
	<b>KIT DE EMBELLECEDORES TIRADOR IZQUIERDO TAU</b> TAU LEFT PULL HANDLE COVER KIT	052432 <table border="1"><tr><td>81</td></tr><tr><td>82</td></tr></table>	81	82	120
81					
82					
	<b>TIRADOR IZQUIERDO TAU + KIT DE EMBELLECEDORES</b> TAU LEFT PULL HANDLE + COVER KIT	052412 <table border="1"><tr><td>81</td></tr><tr><td>82</td></tr></table>	81	82	120
81					
82					
	<b>TIRADOR DESPLAZADO DERECHO TAU</b> TAU RIGHT OFFSET PULL HANDLE	052423 <table border="1"><tr><td>81</td></tr><tr><td>82</td></tr></table>	81	82	121
81					
82					
	<b>KIT DE EMBELLECEDORES TIRADOR DERECHO TAU</b> TAU RIGHT PULL HANDLE COVER KIT	052433 <table border="1"><tr><td>81</td></tr><tr><td>82</td></tr></table>	81	82	121
81					
82					
	<b>TIRADOR DERECHO TAU + KIT DE EMBELLECEDORES</b> TAU RIGHT PULL HANDLE + COVER KIT	052413 <table border="1"><tr><td>81</td></tr><tr><td>82</td></tr></table>	81	82	121
81					
82					

» APERTURA OSCIOBATIENTE TILT & TURN OPENING

REF.

PAG.



**KIT DE BISAGRAS CLX PARA HOJA ACTIVA** (120 kg)  
CLX HINGE KIT FOR ACTIVE SASH (120 kg)

T1113	D	81
	I	

149



**KIT DE BISAGRAS CLX PARA HOJA PASIVA** (120 kg)  
CLX HINGE KIT FOR PASSIVE SASH (120 kg)

T1114	D	81
	I	

149



**KIT CLX PARA CIERRE AL INVERSOR** (SIN CREMONA)  
CLX KIT FOR LOCKING TO INVERTER (WITHOUT CREMONE)

T1133	D	81
	I	

150



**KIT CLX PARA CIERRE AL INVERSOR** (CON CREMONA SIRIUS)  
CLX KIT FOR LOCKING TO INVERTER (WITH SIRIUS CREMONE)

T1118	D	81	S
	I		

150



**KIT CLX PARA MANIOBRA LÓGICA** (SIN CREMONA)  
CLX KIT FOR TILT-BEFORE-TURN (WITHOUT CREMONE)

T1123	D	81
	I	

150



**KIT CLX PARA CIERRE AL MARCO** (SIN CREMONA)  
CLX KIT FOR LOCKING TO FRAME (WITHOUT CREMONE)

T1139	D	81
	I	

151

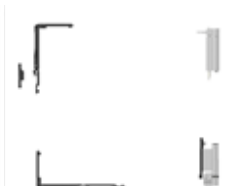

**KIT CLX PARA CIERRE AL MARCO** (CON CREMONA SIRIUS)  
CLX KIT FOR LOCKING TO FRAME (WITH SIRIUS CREMONE)

T1132	D	81	S
	I		

151



**KIT CLX EVO-SECURITY PARA CIERRE AL MARCO** (SIN CREMONA)  
EVO-SECURITY CLX KIT FOR LOCKING TO FRAME (WITHOUT CREMONE)

S1139	D	81
	I	

186



**KIT CLX EVO-SECURITY PARA CIERRE AL MARCO** (CON CREMONA SIRIUS)  
EVO-SECURITY CLX KIT FOR LOCKING TO FRAME (WITH SIRIUS CREMONE)

S1132	D	81	S
	I		

186



**KIT CLX EVO-SECURITY PARA MANIOBRA LÓGICA** (SIN CREMONA)  
EVO-SECURITY CLX KIT FOR TILT-BEFORE-TURN (WITHOUT CREMONE)

S1123	D	81
	I	

187

» **APERTURA ABATIBLE** BOTTOM-HUNG OPENING

**REF.**

**PAG.**

**MANILLA DE FACHADA AP. DERECHAS** (28,5 mm)  
FACADE HANDLE FOR RIGHT-HAND OPENING (28,5 mm)

A1511 81

231

**MANILLA DE FACHADA AP. IZQUIERDAS** (28,5 mm)  
FACADE HANDLE FOR LEFT-HAND OPENING (28,5 mm)

A1512 81

231

**MANILLA DE FACHADA AP. DERECHAS** (32 mm)  
FACADE HANDLE FOR RIGHT-HAND OPENING (32 mm)

A1521 81

231

**MANILLA DE FACHADA AP. IZQUIERDAS** (32 mm)  
FACADE HANDLE FOR LEFT-HAND OPENING (32 mm)

A1522 81

231

**MANILLA DE FACHADA AP. DERECHAS** (25 mm)  
FACADE HANDLE FOR RIGHT-HAND OPENING (25 mm)

A1531 81

231

**MANILLA DE FACHADA AP. IZQUIERDAS** (25 mm)  
FACADE HANDLE FOR LEFT-HAND OPENING (25 mm)

A1532 81

231



» **VENTANA CORREDERA** SLIDING WINDOW

**REF.**

**PAG.**

**CIERRE DE EMBUTIR FÉNIX MINI**  
FENIX MINI RECESSED HANDLE

B03300 81

288

**CIERRE DE EMBUTIR AUTOMÁTICO DRACO MAX**  
DRACO MAX AUTOMATIC RECESSED HANDLE

031000 81

290

**CIERRE DE EMBUTIR MANUAL DRACO MAX**  
DRACO MAX MANUAL RECESSED HANDLE

031000 81 C

290

**CIERRE DE EMBUTIR AUTOMÁTICO DRACO LINE**  
DRACO LINE AUTOMATIC RECESSED HANDLE

030000 81

290

**CIERRE DE EMBUTIR MANUAL DRACO LINE**  
DRACO LINE MANUAL RECESSED HANDLE

030000 81 C

290









# STAC

Disponemos de un departamento técnico cualificado que está a su disposición para cualquier consulta. Si no ha encontrado lo que buscaba póngase en contacto con nosotros a través del correo [info@stac.es](mailto:info@stac.es) o del número de teléfono **[+34] 981 817 036**. Estudiaremos una solución adaptada a sus necesidades.

Dispone de una versión online del catálogo general de herraje en formato .pdf que puede descargar y consultar en el apartado de descargas de nuestra web <https://www.stac.es>.

We have a qualified technical department that is at your complete disposal for any query. If you have not found what you are looking for, please contact us by email at [info@stac.es](mailto:info@stac.es) or by telephone **[+34] 981 817 036**. We will study a solution adapted to your needs.

An online version of the general hardware catalogue is available in .pdf format and can be downloaded and consulted in the download section of our website <https://www.stac.es>.

Estamos a su entera disposición para cualquier consulta. Para más información visite nuestra web o póngase en contacto con nosotros, estudiaremos una solución adaptada a sus necesidades. Disponemos de asesoramiento técnico en español, inglés, francés, alemán e italiano.

STAC is at your disposal for any queries. For more information visit our website or contact us, we will study a solution tailored to your needs. We have technical support in Spanish, English, French, German and Italian.

## STAC Headquarters

☎	[+34] 981 817 036	📍	Polígono industrial PICUSA
📄	[+34] 981 817 037		15900 Padrón, A Coruña
✉	info@stac.es		Spain

## STAC Morocco

☎	[+212] 053952 11 36	📍	Route nationale 1, km 92
📄	[+212] 053952 11 54		Commune rurale Laouamra
✉	maroc@stac.es		Larache, Morocco

## STAC Poland

☎	[+48] 322 630 740	📍	Ul. Kluczevska 2A
✉	polska@stac.es		32-300 Olkusz
			Poland

## STAC México

☎	[+52] 4422517019	📍	Parque Industrial PyME
✉	mexico@stac.es		Carretera estatal 431, Los Cues, km 5.8
			Huimilpan, 76970, Querétaro, México



Follow us!



stac.es





**STAC**  
more than you see

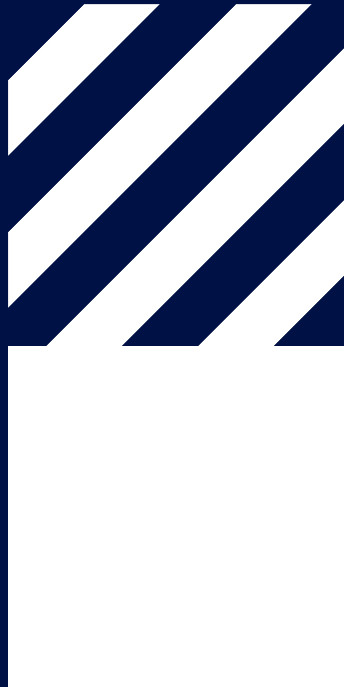

**Solutions for  
aluminium systems**

Soluciones para sistemas de aluminio